



INDINVEST LT

ALUMINIUM  EVOLUTION

Catalogo Generale



INDICE

| | |
|-----------------------|--|
| Introduzione Tecnica | |
| Elenco Accessori | |
| Elenco Guarnizioni | |
| Elenco Attrezzature | |
| Profilati ed Inerzie | |
| Profilati Scala 1:1 | |
| Soluzioni Disponibili | |
| Schede di Taglio | |
| Nodi Scala 1:1 | |

**FINO A NUOVA STAMPA CARTACEA GLI AGGIORNAMENTI
SONO DISPONIBILI SUL SITO WWW.INDINVESTLT.IT**



Introduzione Tecnica

CATALOGO TECNICO - INDICAZIONI GENERALI

MANUALE D'USO

Le informazioni contenute all'interno di questo Catalogo / Manuale, quando seguite scrupolosamente, permettono la realizzazione di infissi efficienti, sicuri e di lunga durata.

Alcune parti di questa documentazione, come ad esempio le distinte di taglio dei profilati, sono il risultato di calcoli teorici che possono risentire di fattori esterni, quali tipo e spessore della finitura superficiale, modello delle attrezzature utilizzate etc. E' quindi sempre consigliato, prima di procedere alla realizzazione delle commesse, eseguire una campionatura preventiva di prova in dimensioni reali, allo scopo di verificare lavorazioni, assemblaggi e prestazioni.

RISERVE GIURIDICHE

I disegni e le informative contenute in questo catalogo sono fornite a solo titolo indicativo e non possono costituire titolo di rivalsa nei confronti della INDINVEST LT s.r.l.

INDINVEST LT s.r.l. declina ogni responsabilità su eventuali errori di stampa o sull'uso improprio del presente catalogo e si riserva la facoltà di modificarne il contenuto senza alcun obbligo di preavviso.

Il presente catalogo è di proprietà della INDINVEST LT s.r.l. così come i suoi contenuti ed immagini che non potranno essere copiati e riprodotti, anche solo parzialmente, o modificati in alcun modo senza la Sua autorizzazione scritta.

DIMENSIONE E PESO DEI PROFILATI

Le dimensioni dei profilati riportate sul presente catalogo sono teoriche, e quindi variabili in funzione delle tolleranze dimensionali di estrusione (in conformità alla norma UNI EN 12020-2), oltretutto in conseguenza di trattamenti di finitura superficiale e di accoppiamento dei profili a taglio termico. Dette variazioni possono influenzare sensibilmente gli accoppiamenti dei profili e/o la facilità di inserimento di accessori o guarnizioni nelle sedi apposite.

Le barre dei profilati vengono fornite alla lunghezza di 6.80 m.

POSA IN OPERA

Nella posa in opera dei serramenti, è necessario valutare opportunamente la tolleranza da mantenere tra il contro-telaio ed il telaio in Alluminio.

Questa tolleranza è variabile secondo le condizioni presenti, ma deve essere comunque tale da garantire un fissaggio completo e sicuro.

L'attacco dei serramenti alle murature presenta varie possibilità di soluzione a seconda della situazione che si presenta, ma deve avvenire con viti, tasselli ed ancoraggi di buona qualità secondo le normali e consolidate regole della buona posa e del buonsenso.

Gli schemi, le lavorazioni, le sezioni e gli attacchi a muro riportati sul presente catalogo hanno valore esemplificativo e non limitativo; essi riguardano, infatti, solo una parte delle casistiche riscontrabili all'atto pratico, che sarebbero altrimenti troppo numerose da citare nella loro interezza.

A fronte di ciò, INDINVEST LT s.r.l. consiglia di fare riferimento alle norme cogenti per la corretta posa in opera dei serramenti.

GUARNIZIONI ED ACCESSORI

Dovranno essere utilizzate esclusivamente le guarnizioni e gli accessori originali studiati e prodotti a garanzia delle prestazioni del sistema. L'impiego di guarnizioni o accessori diversi da quelli indicati comporteranno l'inutilizzabilità dei certificati di prova.

SIGILLANTI

Dovranno essere utilizzati esclusivamente sigillanti con caratteristiche conformi a quanto prescritto dalle norme di riferimento Italiane ed Europee.

LAVORAZIONI

Le lavorazioni per l'assemblaggio dei profili dovranno essere praticate seguendo gli schemi, le distinte e le istruzioni impartite dal produttore del sistema. La realizzazione di infissi costruiti in difformità dalle indicazioni di montaggio fornite dal produttore di sistema comporteranno l'inutilizzabilità dei certificati di prova.

Allo scopo di limitare il processo di corrosione filiforme dell'alluminio si dovrà avere cura di utilizzare soltanto viterie in acciaio inox ed accessori supplementari in acciaio inox o alluminio in lega EN AW6060, oltre che sigillare le parti tagliate ed evitare ristagni di condensa interni.

VERNICIATURA

I profilati dovranno subire trattamenti superficiali conformi agli standard QUALICOAT e QUALANOD ed in caso di verniciatura dei profilati a taglio termico si dovranno supportare gli stessi con mezzi opportuni affinché non subiscano deformazioni durante il trattamento di cottura del rivestimento a 180° mantenendo l'originale rettilineità.

CARATTERISTICHE DELLE VETRAZIONI

La scelta della vetratura da installare sui serramenti realizzati con il sistema oggetto del catalogo dovrà essere effettuata secondo criteri prestazionali per rispondere ai requisiti di sicurezza, di risparmio energetico, di controllo della radiazione solare e di isolamento acustico fissati dalle leggi vigenti.

ISOLAMENTO TERMICO

La scelta delle prestazioni di isolamento termico di un serramento dovrà essere effettuata in conformità alla vigente normativa italiana in materia di risparmio energetico.

La trasmittanza termica di un serramento può essere calcolata in riferimento a quanto contenuto nella norma UNI EN 13830; UNI EN ISO 1263 e per il calcolo secondo le modalità di calcolo riportate nella UNI EN 10077-1-2.

ISOLAMENTO ACUSTICO

La scelta della classe di isolamento acustico di un serramento sarà legata alla destinazione d'uso del locale nel quale l'infisso dovrà essere inserito, oltre che al livello ed alla natura del rumore esterno. Le prestazioni acustiche del serramento in opera sono influenzate da fattori noti (classe di permeabilità all'aria dell'infisso, potere fono isolante del vetro) e da fattori non definibili a priori (altezza dal suolo, presenza di parapetti, orientamento delle sorgenti, sporgenze, spettro sonoro, modalità d'installazione. I valori da rispettare sono quelli indicati dalla vigente normativa Italiana misurabili secondo e le relative norme Europee.

SICUREZZA SUL LAVORO

Le procedure di realizzazione e montaggio in sicurezza dei serramenti, nel rispetto della normativa italiana in tema di salute e sicurezza, sono a cura dei serramentisti. I serramenti dovranno essere concepiti secondo le prescrizioni della normativa vigente Italiana ed Europea in materia di sicurezza delle applicazioni vetrarie e della UNI in materia di marchio CE.

LIMITI D'IMPIEGO

Le dimensioni massime dei serramenti, dei pesi delle ante e degli accessori sono da verificarsi e da determinarsi a cura del costruttore in funzione della geometria dei profilati, della massa, del peso delle vetrazioni/ pannellature, della qualità e della portata degli accessori utilizzati, delle condizioni d'installazione, delle condizioni di applicazione (altezza dal suolo, esposizione, ecc.), e delle condizioni climatiche (velocità di riferimento dei venti, esposizione alla pioggia, ecc.). al costruttore di serramenti si consiglia di fare riferimento alle vigenti normative Europee ed Italiane.

CONSIGLI COSTRUTTIVI PER LIMITARE L'INSORGENZA DI CORROSIONE:

La corrosione filiforme è uno dei problemi più insidiosi che possano manifestarsi nei profilati in Alluminio.

Al fine di contrastarne l'insorgenza, occorre prestare particolare attenzione ad alcuni aspetti in fase di costruzione e posa degli infissi.

In particolare:

Nei limiti del possibile utilizzare per le giunzioni squadrette e cavallotti in Alluminio estruso, lega 6060 o pressofuso, lega UNI 5076.

Le viti di fissaggio devono essere in acciaio inox.

Le parti soggette a taglio o fresature devono essere sigillate accuratamente, con specifici prodotti adatti allo scopo (colle bicomponente ecc.).

Evitare ristagni di acqua (spesso dovuti a fenomeni naturali di condensa), all'interno dei profilati.

SITO INTERNET ED AGGIORNAMENTI

Per aggiornamenti del catalogo e per ogni ulteriore informazione è possibile visitare il nostro sito internet all'indirizzo: WWW.INDINVESTLT.IT

DIAGRAMMI DEI LIMITI DI IMPIEGO

PROFILATI ART. 665002 - 665003 - 665002

- I valori di altezza e larghezza riportati nel diagramma si riferiscono alle dimensioni delle ante.
- Verificare che la freccia del profilato sia compatibile con il vetro impiegato.
- I diagrammi qui riportati non prendono in considerazione la resistenza degli accessori.
- Le curve indicano le dimensioni massime relative alle pressioni indicate

Curve con freccia max 1/300 di H

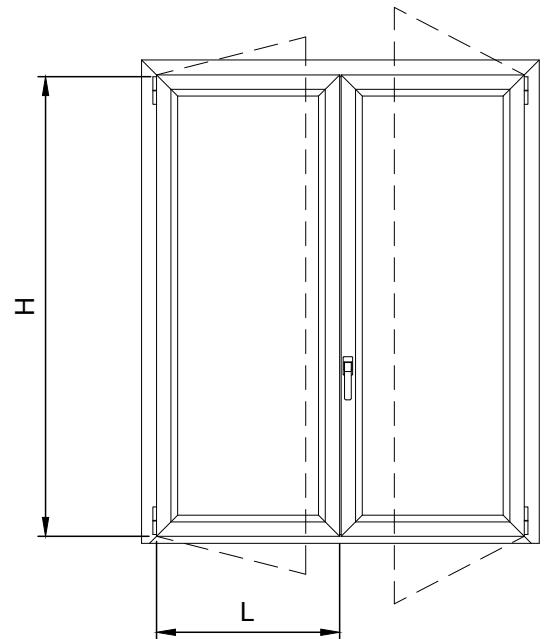
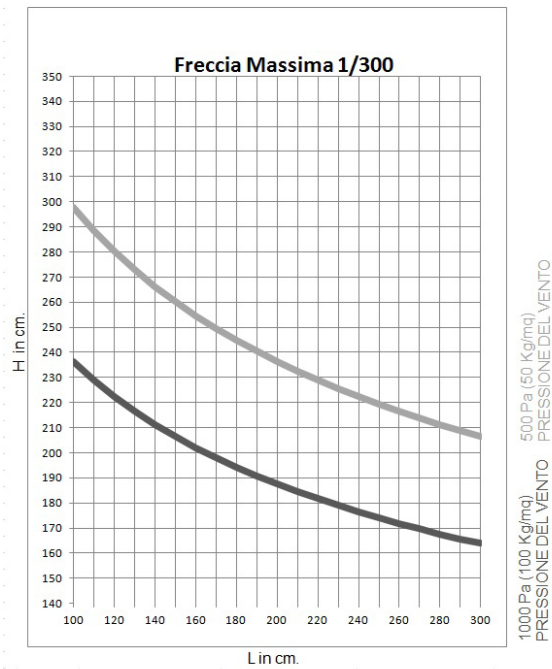

Curve con freccia max 1/200 di H

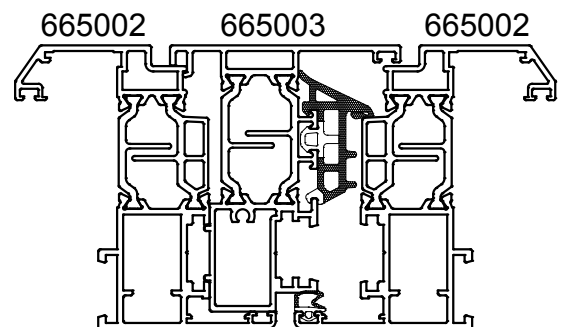

DIAGRAMMI DEI LIMITI DI IMPIEGO

PROFILATI ART. 665011 - 665002



- I valori di altezza e larghezza riportati nel diagramma si riferiscono alle dimensioni delle ante.
- Verificare che la freccia del profilato sia compatibile con il vetro impiegato.
- I diagrammi qui riportati non prendono in considerazione la resistenza degli accessori.
- Le curve indicano le dimensioni massime relative alle pressioni indicate

Curve con freccia max 1/300 di H

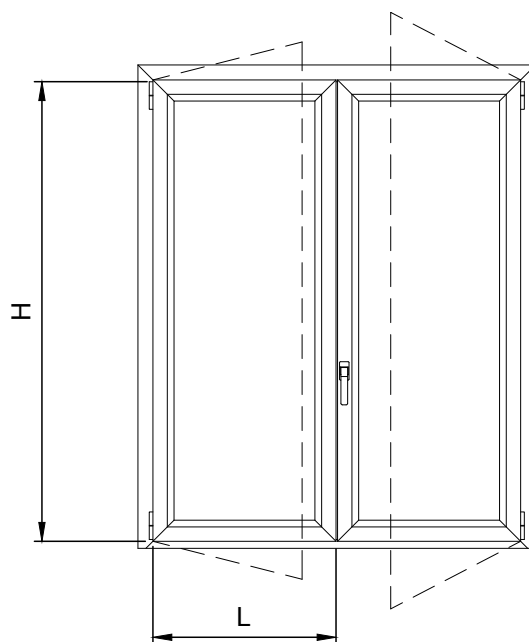
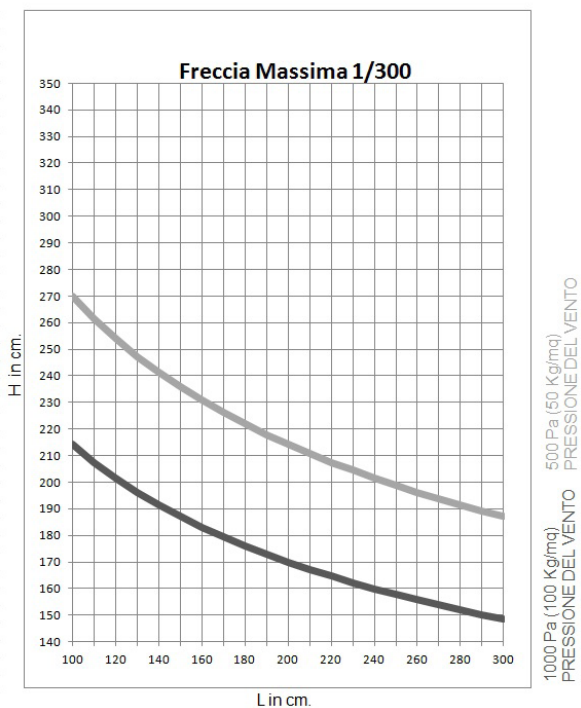

Curve con freccia max 1/200 di H

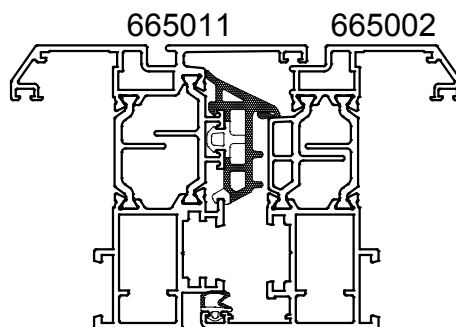
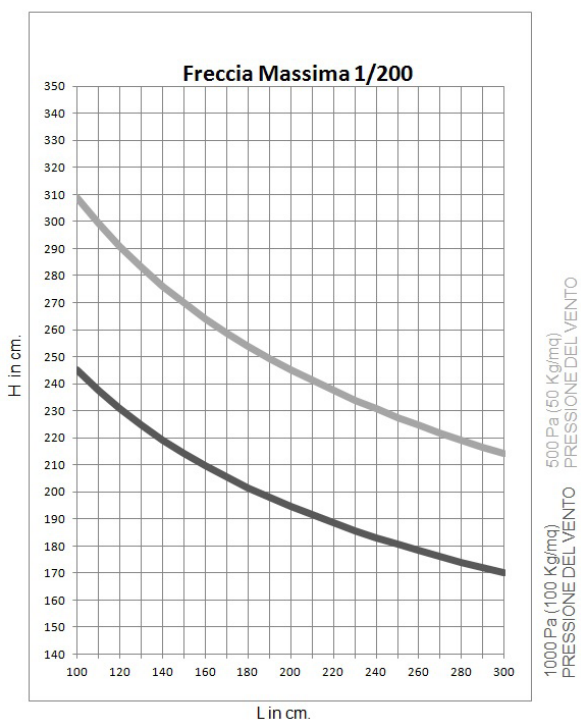

DIAGRAMMI DEI LIMITI DI IMPIEGO

PROFILATI ART. 665014 - 665003 - 665014

- I valori di altezza e larghezza riportati nel diagramma si riferiscono alle dimensioni delle ante.
- Verificare che la freccia del profilato sia compatibile con il vetro impiegato.
- I diagrammi qui riportati non prendono in considerazione la resistenza degli accessori.
- Le curve indicano le dimensioni massime relative alle pressioni indicate

Curve con freccia max 1/300 di H

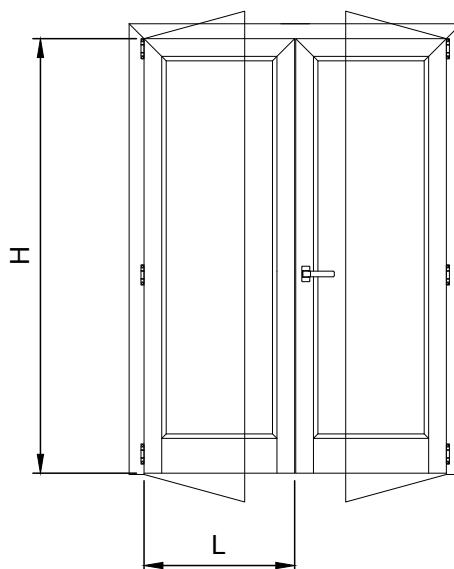

Curve con freccia max 1/200 di H

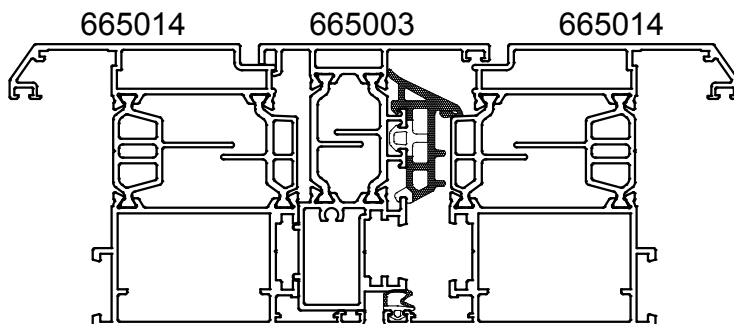
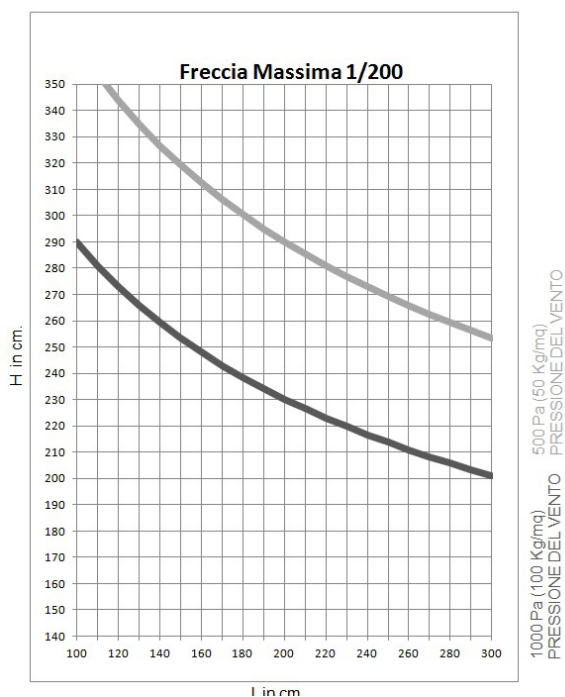

DIMENSIONE MINIMA ANTA

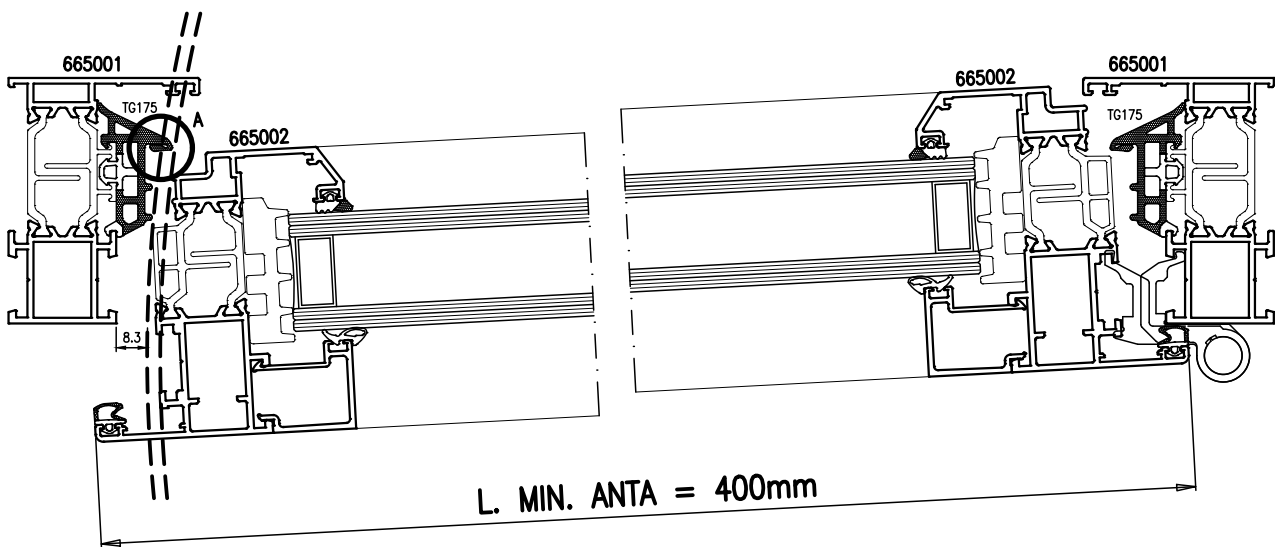

CON LARGHEZZA ANTA = 400 mm

TRA LA GUARNIZIONE TG075 E IL PROFILATO IN ROTAZIONE
RIMANE UNO SPAZIO TEORICO DI POCO MENO DI 1 mm

PART. A

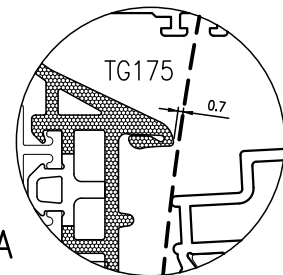

DESCRIZIONE PER CAPITOLATO

Serramenti costruiti con profilati estrusi in lega di alluminio 6060 (EN 573-3), con stato di fornitura T6 (EN 515) e tolleranze su dimensioni e spessori secondo UNI EN 12020.2 e/o UNI EN 755-9.

Il telaio fisso avrà una profondità di 65 mm. e quello mobile di 75 mm. così da assicurare una maggiore resistenza strutturale alle elevate pressioni del vento. La tubolarità in cui sono contenute le squadrette di giunzione degli angoli avrà una larghezza di 18,5 mm., comprensivi di spessore delle pareti del profilato, sia per i telai fissi che per quelli mobili. Per serramenti di rilevanti dimensioni dovranno essere usati per i telai mobili profilati aventi larghezza maggiorata a 43,5 mm. L'aletta di sovrapposizione al muro nella parte interna non dovrà essere inferiore a 26 mm. e dovrà avere una sede per l'alloggiamento della guarnizione di battuta. I profilati avranno caratteristiche di taglio termico, cioè vi sarà separazione tra parte esterna ed interna dei profilati stessi, al fine di contenere il passaggio di calore tra le due parti. Il taglio termico dovrà essere ottenuto mediante l'inserimento di listelli complanari in poliammide rinforzata con fibre di vetro, della profondità totale di 34 mm per il telaio e 30 mm per l'anta. e spessore di 2 mm. Il bloccaggio delle barrette sarà meccanico, con rullatura dei dentini di ancoraggio dall'esterno previa loro zigrinatura per evitare scorrimenti.

Il valore della trasmittanza termica U_f nella configurazione standard non dovrà essere superiore a 1,5 W/ m²K sia per la sezione laterale che per la sezione centrale.

DOGMA

Il sistema di tenuta all'aria sarà a giunto aperto, cioè con guarnizione centrale in E.P.D.M. in doppia densità montata sul telaio fisso ed appoggiante direttamente sull'apposita pinna in poliammide presente sul telaio mobile. Inoltre per ridurre la trasmissione termica e per garantire sempre la corretta ventilazione perimetrale del vetrocamera il perimetro dei tamponamenti (vetro o pannello) sarà contornato da apposita guarnizione isolante in PEX, mentre quello del telaio da guarnizione auto espandente in poliuretano.

Nella traversa inferiore del telaio fisso dovranno essere realizzate delle asole per lo scarico dell'acqua, dotate di apposite cappette in nylon di protezione. Gli angoli dei profilati e della guarnizione centrale dovranno essere sigillati per evitare possibili infiltrazioni di aria e acqua.

In caso di utilizzo di vetri isolanti, nelle traverse inferiori e nei montanti laterali delle ante mobili dovranno essere realizzate altresì asole per lo scarico dell'eventuale acqua di condensa e per la corretta aerazione del vetro.

Il serramento finito presenterà una superficie esterna piana (complanare), con fughe tra telaio fisso e mobile di 5 mm. mentre all'interno il piano delle ante apribili avrà una sporgenza (sormonto) di 10 mm. rispetto al piano del telaio fisso.

I fermavetri saranno a scatto, con opportune sedi per l'inserimento delle guarnizioni di tenuta del vetro.

Gli accessori e le guarnizioni dovranno essere quelli originali, studiati e prodotti per questo sistema di profilati.

Per quanto riguarda la tenuta all'aria, all'acqua ed al vento i serramenti dovranno garantire le seguenti classi di tenuta per le portabalcone ad una e due ante:

| | | | |
|------------------------|--------------|--------------|--------------|
| Permeabilità all'aria: | classe 4 | UNI EN 1026 | UNI EN 12207 |
| Tenuta all'acqua: | classe E1500 | UNI EN 1027 | UNI EN 12208 |
| Resistenza al vento: | classe C5 | UNI EN 12221 | UNI EN 12210 |

L'ottenimento delle caratteristiche di tenuta sopracitate con questi profilati dovrà essere dimostrabile con riproduzione in copia dei risultati del collaudo presso idoneo Istituto, effettuato dal costruttore dei serramenti o, in mancanza, dal produttore dei profilati.

Finitura superficiale dei profilati in alluminio

La protezione e la finitura delle superfici dei profilati dovranno essere effettuate mediante anodizzazione o verniciatura.

- L'anodizzazione, nel colore _____ dovrà essere eseguita secondo quanto previsto dal marchio europeo "EURAS-EWAA / QUALANOD".
- La verniciatura, nel colore _____ secondo tabelle RAL dovrà essere eseguita in base a quanto previsto dal marchio europeo "QUALICOAT".

LIMITI DI IMPIEGO

Il progettista o il serramentista, in fase di determinazione delle dimensioni massime dei serramenti dovrà considerare e valutare oltre alle dimensioni ed alle inerzie dei profilati, anche i fattori inerenti alla posa e alle caratteristiche meteorologiche, quali l'altezza dal suolo, l'esposizione alla pioggia e la velocità dei venti presenti nella zona. Per la conoscenza e l'utilizzo di questi dati, consigliamo di consultare e seguire quanto indicato sulle "Raccomandazioni UNCSAAL" elaborate sulla base delle norme UNI, UNI-EN ed UNI-CNR esistenti in merito.

DESCRIZIONE TECNICA SISTEMA DOGMA

DOGMA, é un sistema per la costruzione di serramenti marcabili



rappresenta la punta di diamante dei nostri

Sistemi in Alluminio a taglio termico.

La grande sezione ed il taglio termico da 34 mm per il telaio e 30 mm per l'anta rendono questo Sistema ideale per l'edilizia privata, ma anche per uffici e strutture dove è importante raggiungere elevate tenute (grazie al sistema di guarnizioni a giunto aperto) ed alto isolamento termico, anche su serramenti di grandi dimensioni.

DOGMA permette l'alloggiamento di vetri con camere di grande spessore o con veneziane interne.

Il sistema è completo sotto ogni aspetto: profilati, accessori e finiture superficiali.

Pertanto si presta alla realizzazione delle più svariate tipologie, comprese finestre a bilico, vetrine e serramenti con anta scorrevole in parallelo.

DOGMA utilizza accessori per camera europea o pista 16 int.9mm, che consentono un'ampia scelta di soluzioni e all'occorrenza facilità di manutenzione, garantendo all'utente finale la totale soddisfazione.

| | |
|--|---|
| TIPO DI SISTEMA : | Sormonto interno - Complanare esterno |
| PROFILATI ESTRUSI : | Lega d'alluminio 6060 Al Mg 0.5, Si 0.4, Fe 0.2 secondo le norme UNI EN 573 |
| STATO DI FORNITURA : | T6 secondo la norma UNI EN 515 (equivalente TA 16) |
| TOLLERANZE DIMENSIONALI E SPESSORI : | UNI EN 12020.2 e/o UNI EN 755-9 |
| SISTEMA DI TENUTA ARIA, ACQUA E VENTO : | |
| FINESTRE E PORTEFINESTRE : | Giunto Aperto a camera europea e/o ferramenta perimetrale con guarnizione centrale |
| PORTE : | Con doppia guarnizione di battuta |
| TAGLIO TERMICO : | Con barrette complanari in poliammide da mm 34-30 |
| DIMENSIONI DEL SISTEMA : | Telaio fisso sezione mm 65 Telaio anta sezione mm 75 Inserimento vetri variabile tra 22 e 56 mm |
| ALTEZZA SEDE VETRO : | mm 22 |
| INSERIMENTO VETRO : | Fermavetro sia rettangolare che arrotondato o sgucciato (aggancio a scatto, con molletta oppure a contrasto) Profili vetro ad infilo normali e maggiorati di vario design |
| GUARNIZIONI : | In gomma sintetica, EPDM - TPE - GOMMA SILICONICA |
| CERTIFICAZIONI : | ISTEDIL di Guidonia (RM) Rapporto di Prova n. 0061/2016 del 16.02.2016 Permeabilità all'aria (UNI EN 1026, UNI EN 12207): Classe 4 Tenuta all'acqua (UNI EN 1027, UNI EN 12208): Classe E1500 Resistenza al vento (UNI EN 12221, UNI EN 12210): Classe C5 Altri certificati del sistema sono a disposizione. |
| TRASMITTANZA TERMICA : | Uf variabile secondo la configurazione adottata, come da calcoli eseguiti da IRCCOS di Samarate (VA) nel pieno rispetto delle norme UNI EN 10077-1 e UNI EN 10077-2. Per certificati contattare l'Ufficio Tecnico. |
| MARCATURA CE : | Come previsto da norma UNI EN 14351-1+A1:2010 Cascading disponibile |

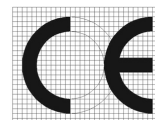

U_w SERRAMENTO CAMPIONE DOGMA

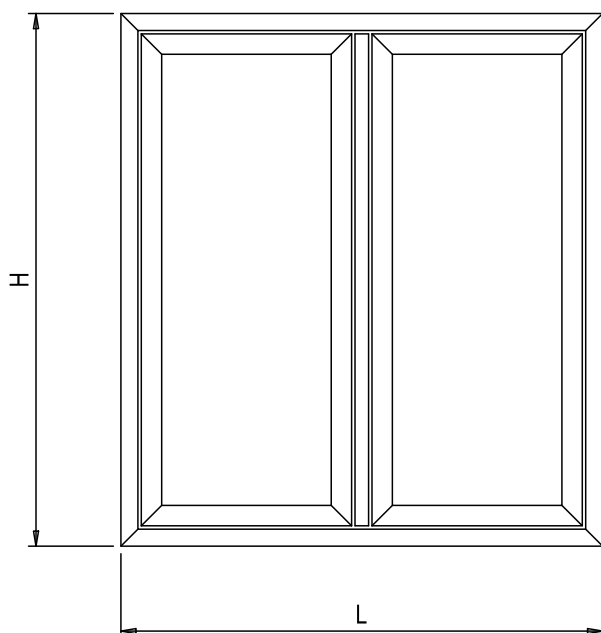

$$U_w = 1.28 \text{ W/m}^2\text{K}$$

VETRO DI $U_g = 1.0 \text{ W/m}^2\text{K}$ CERTIFICATO
CON CANALINA CALDA $\psi = 0.036 \text{ W/mK}$

L : 1535 mm

H : 1480 mm

Dimensioni ammesse per il calcolo U_w su serramento campione fino a 2.3 m² dalla norma UNI EN 14351-1 + A1:2010

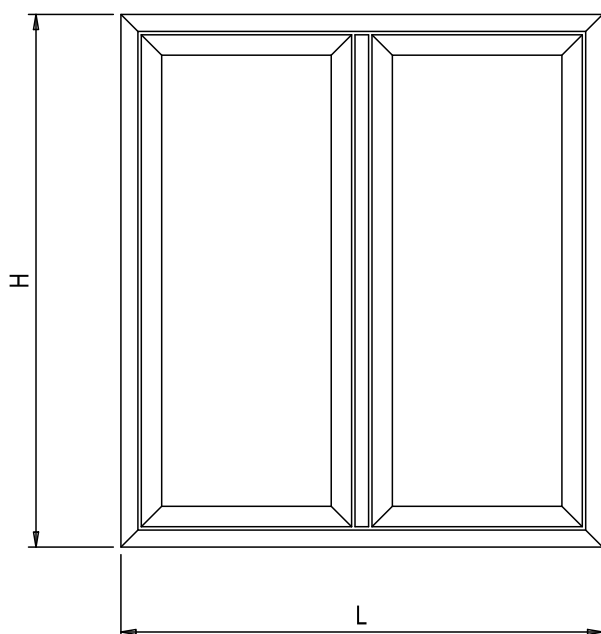

$$U_w = 1.00 \text{ W/m}^2\text{K}$$

VETRO DI $U_g = 0.6 \text{ W/m}^2\text{K}$ CERTIFICATO
CON CANALINA CALDA $\psi = 0.036 \text{ W/mK}$

L : 1535 mm

H : 1480 mm

Marcabili  come previsto da norma UNI EN 14351-1+A1:2010, cascading disponibile.

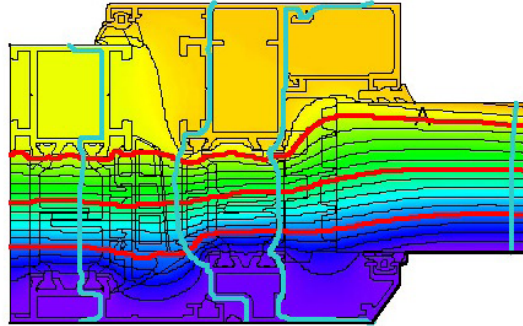

$$U_f = 1.5 \text{ W/m}^2\text{K}$$

CERTIFICATO IRcCOS
N° 1994-CPR-RP1738 del 23.10.2018

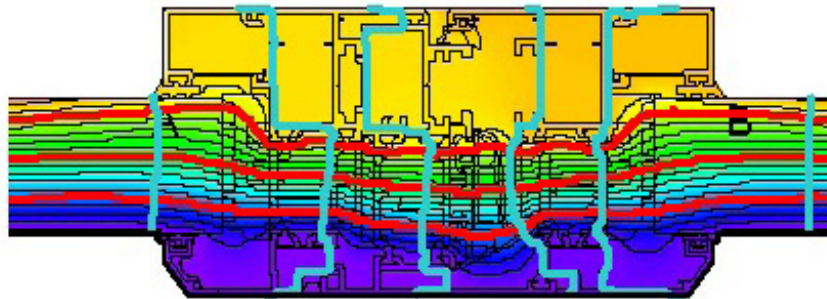

$$U_f = 1.5 \text{ W/m}^2\text{K}$$

CERTIFICATO IRcCOS
N° 1994-CPR-RP1738 del 23.10.2018



PERMEABILITA' ALL'ARIA SECONDO NORME EN 1026 EN 12207

| | | | | |
|---|---|---|---|----------|
| Classe ottenuta dalla finestra campione DOGMA | 1 | 2 | 3 | 4 |
|---|---|---|---|----------|

LA CLASSE OTTENUTA DAL SERRAMENTO INDICA CHE ALLA PRESSIONE DI PROVA PARI A 600 PASCAL IL VOLUME D'ARIA FILTRATA ALL'INTERNO E' IL MINORE POSSIBILE. LA SCALA DI BEAUFORT DI CLASSIFICAZIONE DEL VENTO INDICA CHE 600 PASCAL CORRISPONDONO AD UN VENTO DI CIRCA 110km/h (TEMPESTA VIOLENTA).



TENUTA ALL'ACQUA SECONDO NORME EN 1027 EN 12208

| | | | | | | | | | | |
|---|----|----|----|----|----|----|----|----|----|--------------|
| Classe ottenuta dalla finestra campione DOGMA | 1A | 2A | 3A | 4A | 5A | 6A | 7A | 8A | 9A | E1500 |
|---|----|----|----|----|----|----|----|----|----|--------------|

LA CLASSE OTTENUTA DAL SERRAMENTO SOTTOPOSTO A TEST INDICA CHE NON SI SONO VERIFICATE INFILTRAZIONI D'ACQUA ALL'INTERNO FINO ALLA PRESSIONE DI 1500 PASCAL LA QUANTITA' D'ACQUA UTILIZZATA PER IL TEST E' QUELLA PREVISTA PER SERRAMENTI TOTALMENTE ESPOSTI (A)



RESISTENZA AL VENTO SECONDO NORME EN 12211 EN 12210

| | | | | | |
|--|---|---|----------|---|----------|
| Classe della pressione di prova | 1 | 2 | 3 | 4 | 5 |
| Classe di flessione ottenuta finestra campione DOGMA | A | B | C | | |

LA CLASSE C5 OTTENUTA DAL SERRAMENTO INDICA CHE ESSO, SOTTOPOSTO A 50 CICLI RIPETUTI DI PRESSIONE DI +1000 E - 1000 PASCAL ED ALLA PRESSIONE DI SICUREZZA DI 3000 PASCAL, NON HA RIPORTATO ALCUN DANNO ALLA FUNZIONALITA'. INDICA INOLTRE CHE LA FRECCIA MASSIMA DI INFLESSIONE NON HA SUPERATO 1/300 DELL'ALTEZZA.

TIPOLOGIE REALIZZABILI

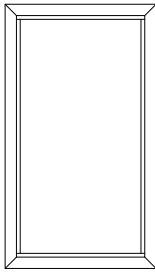

FISSO

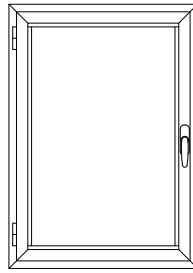

1 ANTA AP. INTERNA

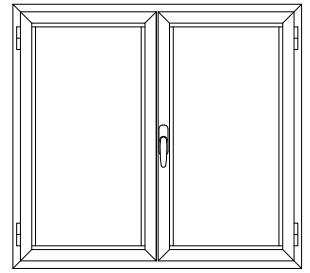

2 ANTE AP. INTERNA Z-RIP-Z

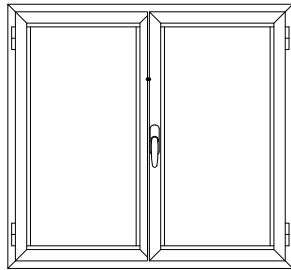

2 ANTE AP. INTERNA Z-T

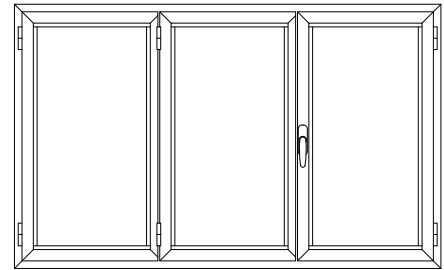

3 ANTE AP. INTERNA Z-T

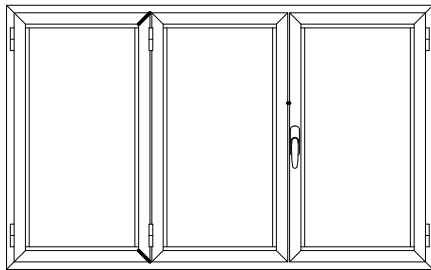

3 ANTE AP. INTERNA Z-RIP-Z

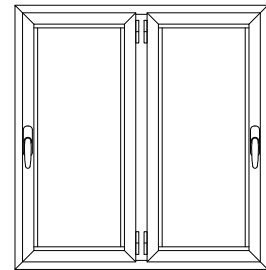

2 ANTE MONTANTE CENTRALE

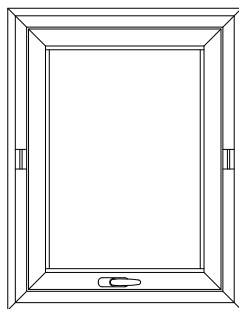

BILICO ORIZZONTALE

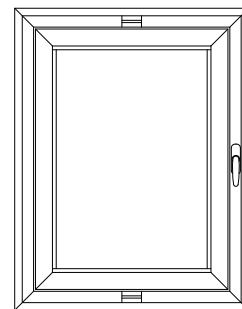

BILICO VERTICALE

TIPOLOGIE REALIZZABILI

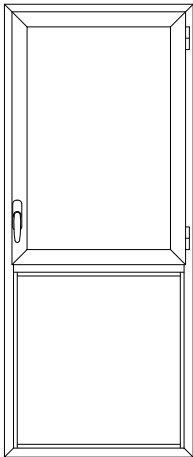

ANTA A SCOMPARSA
CON SOTTOLUCE FISSO

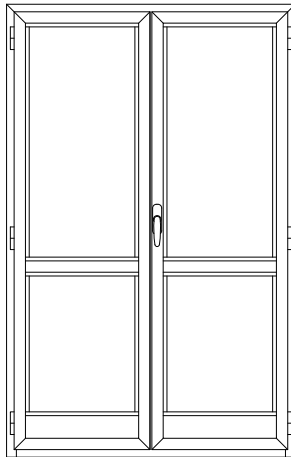

PORTABALCONE CON SOGLIA RIBASSATA

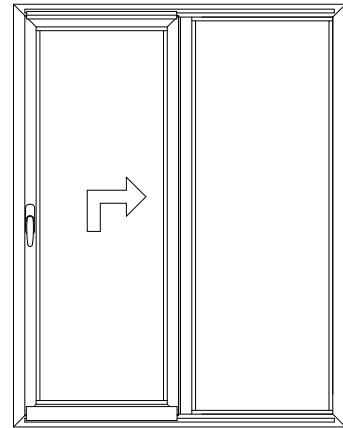

SCORREVOLE PARALLELO

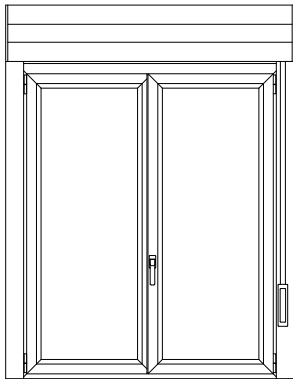

MONOBLOCCO 2 ANTE

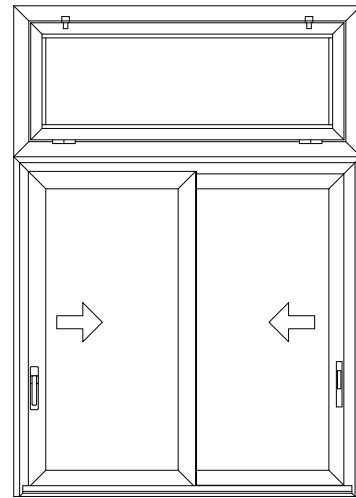

SCORREVOLE 2 ANTE CON SOPRALUCE VASISTAS

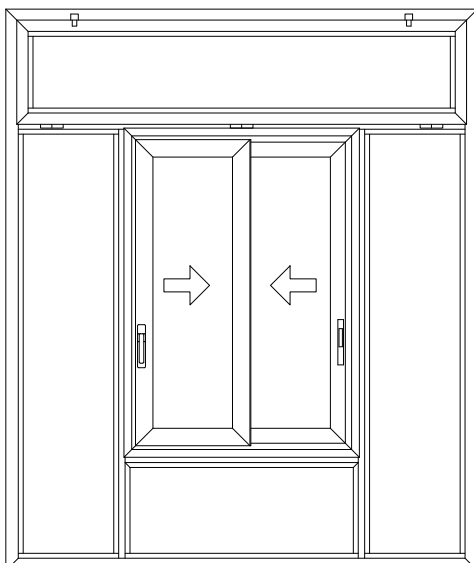

VETRINA CON INSERITO SCORREVOLE 2 ANTE
E SOPRALUCE VASISTAS

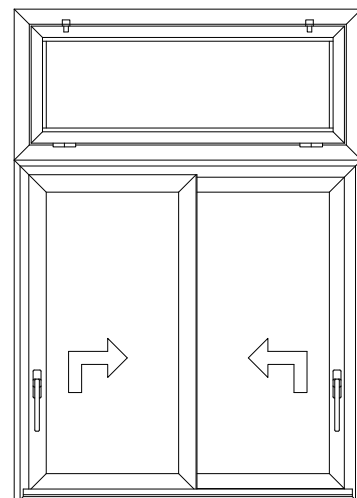

ALZANTE-SCORREVOLE 2 ANTE
CON SOPRALUCE VASISTAS

TIPOLOGIE REALIZZABILI

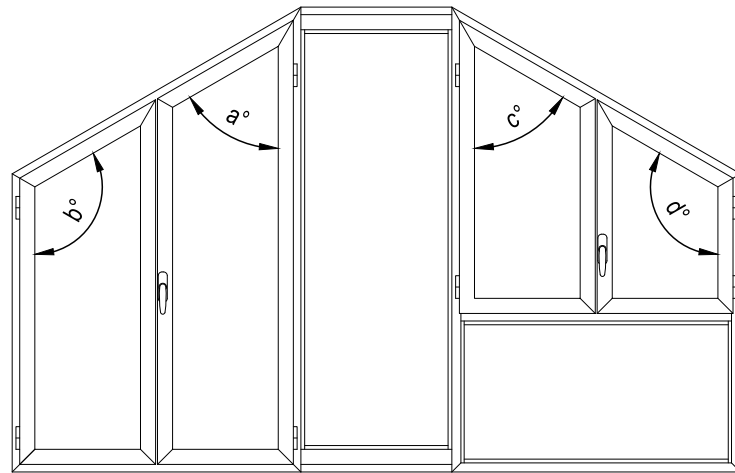

SERRAMENTI FUORI SQUADRO COMBINATI

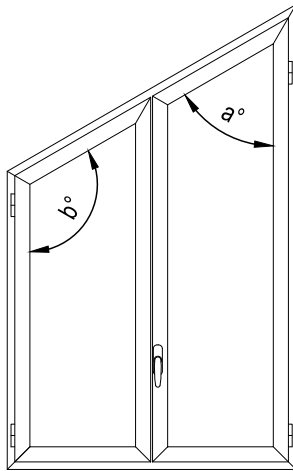

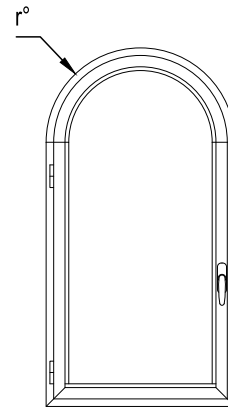

SERRAMENTI FUORI SQUADRO



SERRAMENTI CURVI





IN CASO DI REALIZZAZIONE DI SERRAMENTI FUORI SQUADRO O DI SERRAMENTI CURVI OCCORRE VERIFICARE ATTENTAMENTE , ANCHE IN FUNZIONE DELLA TIPOLOGIA DI APERTURA (BATTENTE , WASISTAS , BILICO , SPORGERE) , CHE LE CARATTERISTICHE GEOMETRICHE E LE DIMENSIONI (ANGOLO DI INCLINAZIONE , RAGGIATURA DELLA PARTE CURVA , ACCESSORISTICA UTILIZZATA) CONSENTANO IL CORRETTO SVINCOLO DELLE PARTI MOBILI.



- Elenco Accessori 
- Elenco Guarnizioni 
- Elenco Attrezzature 

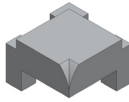

LE IMMAGINI SONO INDICATIVE E NON IMPEGNATIVE

| SAGOMA | ARTICOLO | MATERIALE / COLORE | DESCRIZIONE |
|---|-------------|--------------------|---|
|  | G101 | NYLON | CAPPETTA PER DRENAGGIO ACQUA |
| | | VARI | SCATOLA DA : 1000 Pz. |
|  | G112 | ACCIAIO | SQUADRETTA ALLINEAMENTO ALETTE |
| | | INOX | SCATOLA DA : 1000 Pz. |
|  | G196 | ALLUMINIO | KIT PIASTRE DI FISSAGGIO FRIZIONI A BILICO TA060 |
| | | GREZZO | SCATOLA DA : 2 Cp. |
|  | G197 | ALLUMINIO | VITE AGGIUNTIVA PER CAVALLOTTO TS083 |
| | | GREZZO | SCATOLA DA : 100 Pz. |
|  | G199 | ALLUMINIO | CAVALLOTTO PER TRAVERSI 665020 - 665041 |
| | | GREZZO | SCATOLA DA : 100 Pz. |
|  | G218 | ALLUMINIO | SPINA DIAMETRO 8 PER CAVALLOTTO INTERNO ART. G199 - TS083 |
| | | GREZZO | SCATOLA DA : 400 Pz. |

| SAGOMA | ARTICOLO | MATERIALE / COLORE | DESCRIZIONE |
|---|-------------|--------------------|--|
|  | G220 | ALLUMINIO | SQUADRETTA DI ALLINEAMENTO COPRIFILI 40113 - 40114 |
| | | GREZZO | SCATOLA DA : 100 Pz. |
|  | G231 | ALLUMINIO | ANGOLO PER FERMAVETRI ARROTONDATI |
| | | VARI | SCATOLA DA : 100 Pz. |
|  | G255 | NYLON | SQUADRETTA DI ALLINEAMENTO COPRIFILO 40245 |
| | | NERO | SCATOLA DA : 50 Pz. |
|  | G266 | ZAMA | SPINA 3 mm A FRATTURA PROGRAMMATA PER SQUADRETT TUBOLARITÁ ESTERNA ART. TS079 - TS081 E CAVALLOTTI ESTERNI |
| | | GREZZO | SCATOLA DA : 400 Pz. |
|  | G268 | ALLUMINIO | SQUADRETTA DI ALLINEAMENTO 15.9 x 1 mm PER ANTE/TELA DA |
| | | GREZZO | SCATOLA DA : 50 Pz. |
|  | G269 | ALLUMINIO | SQUADRETTA DI ALLINEAMENTO DA 14.4 x 1 mm PER ANTE/TELA I |
| | | GREZZO | SCATOLA DA : 50 Pz. |

| SAGOMA | ARTICOLO | MATERIALE / COLORE | DESCRIZIONE |
|---|--------------|--------------------|---|
|  | G501N | ALLUMINIO | SQUADRETTA DI ALLINEAMENTO A CAMME \ CAVALLOTTO PER TRAVERSI SCATOLA DA : 250 Pz. |
| | | GREZZO | |
|  | G2001 | ALLUMINIO | VITE PER SQUADRETTA AD ESPANSIONE SCATOLA DA : 300 Pz. |
| | | GREZZO | |
|  | G2002 | ALLUMINIO | SPINA PER SQUADRETTA AD ESPANSIONE SCATOLA DA : 300 Pz. |
| | | GREZZO | |
|  | G2007 | ALLUMINIO | SQUADRETTA AD ESPANSIONE PER TUBOLARITÀ MAGGIORATA ART. 665016 - 665064 SCATOLA DA : 100 Pz. |
| | | GREZZO | |
|  | G2009 | ALLUMINIO | VITE MAGGIORATA PER SQUADRETTA AD ESPANSIONE TS080 SCATOLA DA : 300 Pz. |
| | | GREZZO | |
|  | GT118 | NYLON | TAPPI PER GOCCIOLATOIO UNIVERSALE ART. 40269 SCATOLA DA : 25 Pz. |
| | | NERO | |

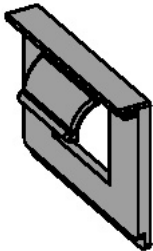
| SAGOMA | ARTICOLO | MATERIALE / COLORE | DESCRIZIONE |
|---|--------------|--------------------|--|
|  | GT131 | NYLON | TAPPI PER CASSONETTO PROFILATI 1184 - 1185 SCATOLA DA : 70 Pz. |
| | | NERO | |
|  | GT132 | NYLON | TAPPI INVITO TAPPARELLA PROFILATO 40038 SCATOLA DA : 500 Pz. |
| | | NERO | |
|  | GT134 | NYLON | CLIP AGGANCIAMENTO FERMAVETRI SCATOLA DA : 200 Pz. |
| | | BIANCO | |
|  | S3001 | ACCIAIO INOX | SPINA 3 mm A FRATTURA PROGRAMMATA PER SQUADRETTE TUBOLARITÀ ESTERNA ART. TS079 - TS081 E CAVALLOTTI ESTERNI SCATOLA DA : 400 Pz. |
| | | GREZZO | |
|  | TA075 | NYLON | REGOLO CAMERA SEMPLICE SCATOLA DA : 200 Pz. |
| | | NERO | |
|  | TA076 | NYLON | REGOLO CAMERA MAGGIORATA SCATOLA DA : 200 Pz. |
| | | NERO | |

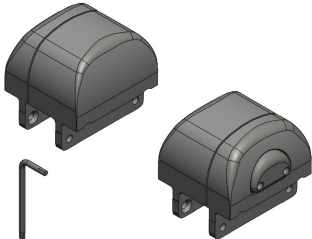
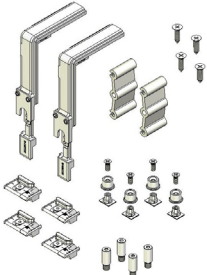
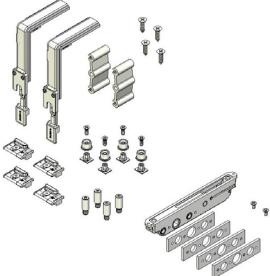
| SAGOMA | ARTICOLO | MATERIALE / COLORE | DESCRIZIONE |
|---|---------------|--------------------|--|
|  | TA1000 | NYLON | MOLLETERIA RITEGNO IMBOTTE |
| | | NERO | SCATOLA DA : 50 Pz. |
|  | TS001 | ALLUMINIO | SQUADRETTA DI ASSEMBLAGGIO PROFILATO 665036 |
| | | GREZZO | SCATOLA DA : 150 Pz. |
|  | TS002 | ALLUMINIO | SQUADRETTA DI ASSEMBLAGGIO PROFILATO 665019 |
| | | GREZZO | SCATOLA DA : 150 Pz. |
|  | TA060 | ZAMA | FRIZIONI PER BILICO |
| | | VARI | SCATOLA DA : 4 Cp. |
|  | TA061 | MISCELLANEA | KIT CHIUSURA BILICO A 4 PUNTI PER CREMONESE (NON INCLUSA) |
| | | | SCATOLA DA : 1 Pz. |
|  | TA062 | MISCELLANEA | KIT CHIUSURA BILICO A 4 PUNTI PER MARTELLINA (NON INCLUSA) |
| | | | SCATOLA DA : 1 Pz. |

| SAGOMA | ARTICOLO | MATERIALE / COLORE | DESCRIZIONE |
|---|--------------|--------------------|--|
|  | TS073 | ALLUMINIO | CAVALLOTTO ESTERNO PER TRAVERSI STANDARD |
| | | GREZZO | SCATOLA DA : 100 Pz. |
|  | TS074 | ALLUMINIO | CAVALLOTTO ESTERNO PER TRAVERSI MAGGIORATI |
| | | GREZZO | SCATOLA DA : 100 Pz. |
|  | TS077 | ALLUMINIO | SQUADRETTA A PULSANTE PER TUBOLARITÀ INTERNA STANDARD |
| | | GREZZO | SCATOLA DA : 250 Pz. |
|  | TS078 | ALLUMINIO | SQUADRETTA AD ESPANSIONE PER TUBOLARITÀ INTERNA STANDARD |
| | | GREZZO | SCATOLA DA : 200 Pz. |
|  | TS079 | ALLUMINIO | SQUADRETTA A CIANFRINARE\SPINARE PER TUBOLARITÀ ESTERNA STANDARD |
| | | GREZZO | SCATOLA DA : 200 Pz. |
|  | TS080 | ALLUMINIO | SQUADRETTA A CIANFRINARE\SPINARE\AVVITARE AD ESPANSIONE PER TUBOLARITÀ INTERNA MAGGIORATA |
| | | GREZZO | SCATOLA DA : 150 Pz. |

| SAGOMA | ARTICOLO | MATERIALE / COLORE | DESCRIZIONE |
|---|---------------|--------------------|---|
|  | TS081 | ALLUMINIO | SQUADRETTA A CIANFRINARE\SPINARE PER TUBOLARITÀ ESTERNA MAGGIORATA SCATOLA DA : 250 Pz. |
| | | GREZZO | |
|  | TS082 | ALLUMINIO | PLACCHETTA DI COMPENSAZIONE PER G501N CAVALLOTTO TRAVERSI SU ANTE SGUSCIATE E ARROTONDATE SCATOLA DA : 50 Pz. |
| | | GREZZO | |
|  | TS083 | ALLUMINIO | CAVALLOTTO INTERNO PER TRAVERSI MAGGIORATI FASCE E ZOCCOLI SCATOLA DA : 100 Pz. |
| | | GREZZO | |
|  | TS084 | ALLUMINIO | SQUADRETTA TUBOLARITÀ ESTERNA ANTA A SCOMPARSA ART. 665047 SCATOLA DA : 40 Pz. |
| | | GREZZO | |
|  | TS088 | ALLUMINIO | CAVALLOTTO ESTERNO PER FASCE E ZOCCOLI SCATOLA DA : 100 Pz. |
| | | GREZZO | |
|  | TS1001 | ALLUMINIO | SQUADRETTA DI ALLINEAMENTO PER TELAI E IMBOTTI SCATOLA DA : 250 Pz. |
| | | GREZZO | |

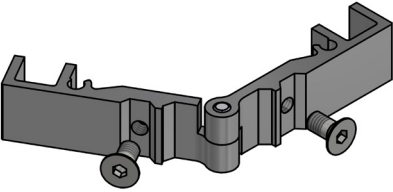
| SAGOMA | ARTICOLO | MATERIALE / COLORE | DESCRIZIONE |
|--|--------------|--------------------|---|
|  | TS085 | ALLUMINIO | SQUADRETTA ANGOLO VARIABILE PROFILATI STANDARD |
| | | GREZZO | SCATOLA DA : 25 Pz. |
|  | TS093 | ALLUMINIO | SQUADRETTA ANGOLO VARIABILE PROFILATI MAGGIORATI |
| | | GREZZO | SCATOLA DA : 25 Pz. |
|  | TA089 | NYLON | REGOLO DISTANZIATORE |
| | | NERO | SCATOLA DA : 50 Pz. |

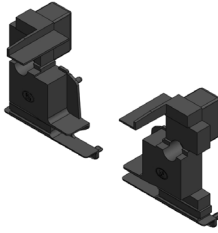
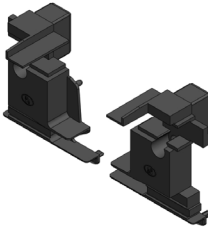
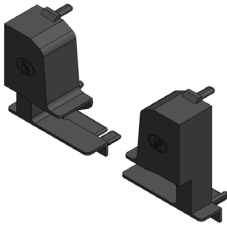
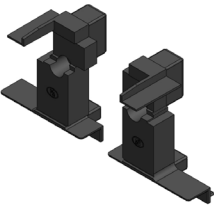
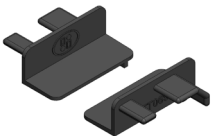
| SAGOMA | ARTICOLO | MATERIALE / COLORE | DESCRIZIONE |
|---|--------------|--------------------|--|
|  | TT065 | NYLON | TAPPO RIPORTO CENTRALE ART. 665003 - 665017 |
| | | NERO | SCATOLA DA : 24 Pz. |
|  | TT066 | NYLON | TAPPO RIPORTO CENTRALE ART. 665018 - 665065 PISTA 16 INT 9 mm |
| | | NERO | SCATOLA DA : 24 Pz. |
|  | TT067 | NYLON | TAPPO ANTERIORE PER SOLUZIONE TZ ART.665011 SOLO PER ANTA SGUSCIATA |
| | | NERO | SCATOLA DA : 24 Pz. |
|  | TT068 | NYLON | TAPPO RIPORTO CENTRALE ART. 665038 APERTURA ESTERNA |
| | | NERO | SCATOLA DA : 24 Pz. |
|  | TT069 | NYLON | TAPPO POSTERIORE PER SOLUZIONE TZ ART.665011 SOLO PER ANTA SGUSCIATA |
| | | NERO | SCATOLA DA : 24 Pz. |

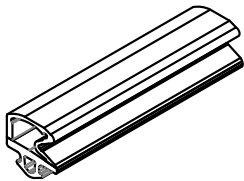
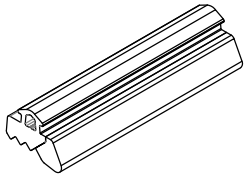
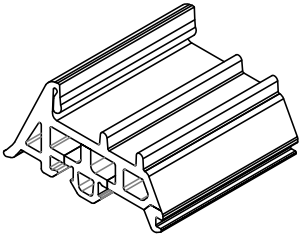
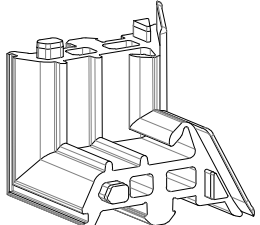
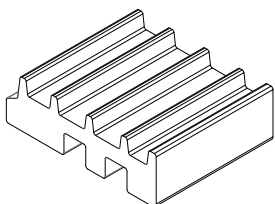
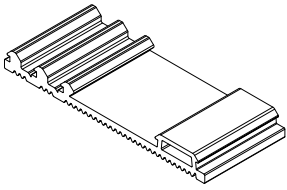
| SAGOMA | ARTICOLO | MATERIALE / COLORE | DESCRIZIONE |
|---|--------------|--------------------|---|
|  | TG031 | E.P.D.M. + ESPANSO | GUARNIZIONE DI BATTUTA INTERNA SCATOLA DA : 200 ml |
| | | NERO | |
|  | TG032 | E.P.D.M. + ESPANSO | GUARNIZIONE CINGIVETRO ESTERNA DA 3 mm SCATOLA DA : 250 ml |
| | | NERO | |
|  | TG175 | E.P.D.M. + ESPANSO | GUARNIZIONE DI TENUTA CENTRALE IN DOPPIA DENSITÀ SCATOLA DA : 50 ml |
| | | NERO | |
|  | TG176 | E.P.D.M. | ANGOLO VULCANIZZATO PER GUARNIZIONE TG175 APERTURA INTERNA SCATOLA DA : 40 Pz. |
| | | NERO | |
|  | TG300 | PEX | GUARNIZIONE SOTTOVETRO ISOLANTE SCATOLA DA : 100 ml |
| | | GRIGIO | |
|  | TG302 | E.P.D.M. | GUARNIZIONE ISOLANTE SCATOLA DA : 30 ml |
| | | NERO | |

| SAGOMA | ARTICOLO | MATERIALE / COLORE | DESCRIZIONE |
|--|--------------|--------------------|--|
|  | TG304 | E.P.D.M. | GUARNIZIONE INTERNA CINGIVETRO DA 3 mm A 4 mm |
| | | NERO | SCATOLA DA : 600 ml |
|  | TG305 | E.P.D.M. | GUARNIZIONE INTERNA CINGIVETRO DA 5 mm A 6 mm |
| | | NERO | SCATOLA DA : 320 ml |
|  | TG306 | E.P.D.M. | GUARNIZIONE INTERNA CINGIVETRO DA 7 mm A 8 mm |
| | | NERO | SCATOLA DA : 200 ml |

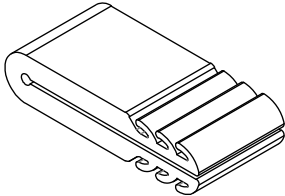
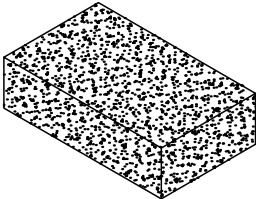
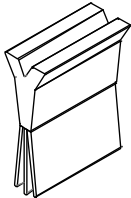
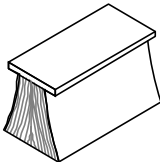
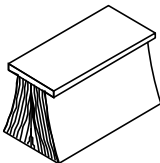

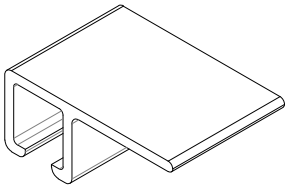
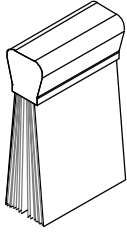
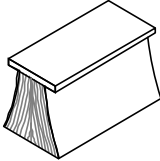
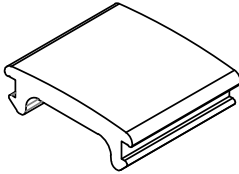
| SAGOMA | ARTICOLO | MATERIALE / COLORE | DESCRIZIONE |
|---|-------------|--------------------|--|
|  | Z130 | E.P.D.M. | GUARNIZIONE GIUNTO ACCOPPIAMENTO NASTRI SCATOLA DA : 60 ml |
| | | NERO | |
|  | Z119 | POLIURETANO | GUARNIZIONE ISOLANTE SCATOLA DA : 10 ml |
| | | GRIGIO | |
|  | Z600 | PVC + ELAPRENE | GUARNIZIONE PER SOTTOPORTE SCATOLA DA : 300 ml |
| | | NERO | |
|  | Z601 | SPAZZOLINO | SPAZZOLINO 4.8 x 15 SCATOLA DA : 275 ml |
| | | | |
|  | Z602 | SPAZZOLINO | SPAZZOLINO PER CIELINO CASSONETTO 6.9 x 14 SCATOLA DA : 150 ml |
| | | | |

| SAGOMA | ARTICOLO | MATERIALE / COLORE | DESCRIZIONE |
|---|-------------|--------------------|--|
|  | Z801 | ALLUMINIO | PROFILATO UNIVERSALE PORTASPAZZOLINO SCATOLA DA : 2.5 ml |
| | | GREZZO | |
|  | Z803 | SPAZZOLINO | SPAZZOLINO CON SUPPORTO ZINCATO 31.8mm SCATOLA DA : 400 ml |
| | | | |
|  | Z804 | SPAZZOLINO | SPAZZOLINO 4.8 x 11 SCATOLA DA : 400 ml |
| | | | |
|  | Z805 | E.P.D.M. | COPRICAVA A SCATTO PER CAVA CAMERA EUROPEA SCATOLA DA : 300 ml |
| | | NERO | |

| SAGOMA | ARTICOLO | MATERIALE / COLORE | DESCRIZIONE |
|---|--------------|--------------------|--|
|  | | | COLLANTE MONOCOMPONENTE REATTIVO ALL'UMIDITÀ PER INCOLLAGGIO ANGOLI |
|  | GA028 | MISCELLANEA | RUOTA INFILA-GUARNIZIONE TG185 SCATOLA DA : 1 ml |
|  | GA112 | ALLUMINIO | DIMA PER FORO 3mm PER CAVALLOTTO ESTERNO SCATOLA DA : 1 Pz. |
|  | GA065 | MISCELLANEA | CIANFRINATRICE MANUALE UTILIZZARE COLTELLI DA 3mm SCATOLA DA : 1 Pz. |

| SAGOMA | ARTICOLO | MATERIALE / COLORE | DESCRIZIONE |
|---|---------------|--------------------|---|
|  | GFD1 | ACCIAIO | GRUPPO FRESA PER LAVORAZIONE TRAVERSI\FASCE\ZOCOLI PER UNIONE CON TELAIO SCATOLA DA : NO MAGAZZINO |
| | | GREZZO | |
|  | GFD2 | ACCIAIO | GRUPPO FRESA PER LAVORAZIONE TRAVERSI\FASCE\ZOCOLI PER UNIONE CON ANTE SGUSCIATE O ARROTONDATE SCATOLA DA : NO MAGAZZINO |
| | | GREZZO | |
|  | GFD3 | ACCIAIO | GRUPPO FRESA PER LAVORAZIONE TRAVERSI\FASCE\ZOCOLI PER UNIONE CON ANTE PIANE SCATOLA DA : NO MAGAZZINO |
| | | GREZZO | |
|  | GFDTZ1 | ACCIAIO | GRUPPO FRESA PER LAVORAZIONE ANTA Z CE PER CENTRALE TZ SCATOLA DA : NO MAGAZZINO |
| | | GREZZO | |
|  | GFDTZ2 | ACCIAIO | GRUPPO FRESA PER LAVORAZIONE ANTA T CE PER CENTRALE TZ SCATOLA DA : NO MAGAZZINO |
| | | GREZZO | |

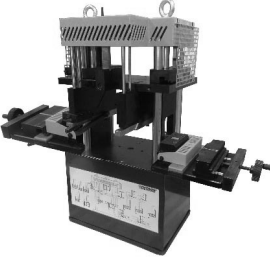
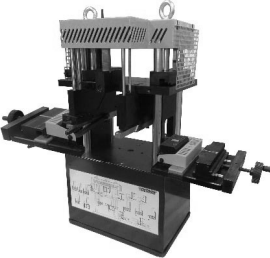
PUNZONATRICI ESISTENTI LAVORAZIONI ESEGUITE

| | | |
|---|---|--|
|  | <p style="text-align: center;">GA101 + GA136</p> | <p style="text-align: center;">LAVORAZIONI :</p> <ol style="list-style-type: none"> 1 - FORO D.8mm PER SQUAD. INT. MULTIF. 2 - FORO D.8mm PER SQUAD. INT. A PULSANTE 3 - CAVALLOTTO INTERNO 4 - AERZIONE VETRO 5 - SCARICO ACQUA 6 - CREMONESE 7 - FORATURA ASTA DI COMANDO 8 - ASPORTAZIONE DENTINI PASS. ASTINA 9 - FORO D.3mm PER SQUAD. ESTERNA |
|  | <p style="text-align: center;">GA100 + GA037 GA039 GA136</p> | <p style="text-align: center;">LAVORAZIONI :</p> <ol style="list-style-type: none"> 1 - FORO D.8mm PER SQUAD. INT. MULTIF. 2 - FORO D.8mm PER SQUAD. INT. A PULSANTE 3 - CAVALLOTTO INTERNO 4 - AERZIONE VETRO 5 - SCARICO ACQUA 6 - CREMONESE 7 - FORATURA ASTA DI COMANDO 8 - ASPORTAZIONE DENTINI PASS. ASTINA 9 - FORO D.3mm PER SQUAD. ESTERNA |
|  | <p style="text-align: center;">GA003 + GA037 GA039 GA082 GA083C GA136</p> | <p style="text-align: center;">LAVORAZIONI :</p> <ol style="list-style-type: none"> 1 - FORO D.8mm PER SQUAD. INT. MULTIF. 2 - FORO D.8mm PER SQUAD. INT. A PULSANTE 3 - CAVALLOTTO INTERNO 4 - AERZIONE VETRO 5 - SCARICO ACQUA 6 - CREMONESE 7 - FORATURA ASTA DI COMANDO 8 - ASPORTAZIONE DENTINI PASS. ASTINA 9 - FORO D.3mm PER SQUAD. ESTERNA |

GA037 - GA039 - GA082 - GA083C - GA136 : ATTREZZATURE COMPLEMENTARI





GA003 - GA100 - GA101 : PUNZONATRICI NON PIÙ COMMERCIALIZZATE

PUNZONATRICI ESISTENTI ELENCO ATTREZZATURE

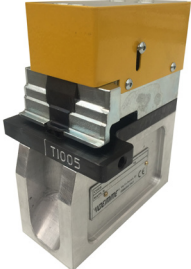
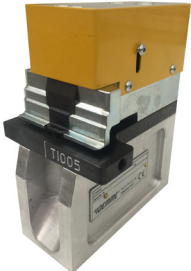

| | | | |
|--|---------------|--------------|--|
| | GA136 | MISCELLANEA | PUNZONATRICE PER FORO 3 mm SQUADRETTA ESTERNA SCATOLA DA : 1 Pz. |
| | | GA037 | MISCELLANEA |
| | GA039 | | PVC |
| | | GA082 | MISCELLANEA |
| | GA083C | | MISCELLANEA |

ABACO TRACIANTI

| SAGOMA | ARTICOLO | MATERIALE / COLORE | DESCRIZIONE |
|---|--------------|--|--|
|  | T1001 | MISCELLANEA | <p style="text-align: center;">TRACIANTE FORO D.8 mm + ASOLA PER SQUADRETTE INTERNE PER TELAI E ANTE</p> <p>SCATOLA DA : 1 Pz.</p> |
| | | UTILIZZARE CON UNITÀ DI SPINTA DA ACQUISTARE SEPARATAMENTE | |
|  | T1002 | MISCELLANEA | <p style="text-align: center;">TRACIANTE FORO D.10,5 mm PER CAVALLOTTI INTERNI</p> <p>SCATOLA DA : 1 Pz.</p> |
| | | UTILIZZARE CON UNITÀ DI SPINTA DA ACQUISTARE SEPARATAMENTE | |
|  | T1003 | MISCELLANEA | <p style="text-align: center;">TRACIANTE FORO D.3 mm PER SQUADRETTA ESTERNA PER TELAI E ANTE</p> <p>SCATOLA DA : 1 Pz.</p> |
| | | UTILIZZARE CON UNITÀ DI SPINTA DA ACQUISTARE SEPARATAMENTE | |
|  | T1004 | MISCELLANEA | <p style="text-align: center;">TRACIANTE CREMONESE, SPUNTATURA ALETTE E ASTINA</p> <p>SCATOLA DA : 1 Pz.</p> |
| | | UTILIZZARE CON UNITÀ DI SPINTA DA ACQUISTARE SEPARATAMENTE | |
|  | T1005 | MISCELLANEA | <p style="text-align: center;">TRACIANTE ASOLA 26,5 x 10.1 PER SCARICO ACQUA</p> <p>SCATOLA DA : 1 Pz.</p> |
| | | UTILIZZARE CON UNITÀ DI SPINTA DA ACQUISTARE SEPARATAMENTE | |
|  | T1006 | MISCELLANEA | <p style="text-align: center;">TRACIANTE ASOLA 20x3 mm PER SCARICO CONDENSA</p> <p>SCATOLA DA : 1 Pz.</p> |
| | | UTILIZZARE CON UNITÀ DI SPINTA DA ACQUISTARE SEPARATAMENTE | |

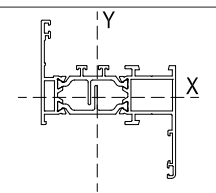
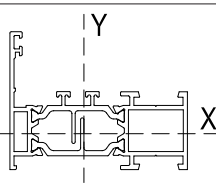
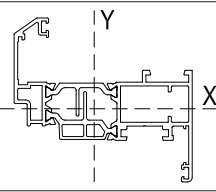
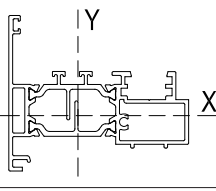
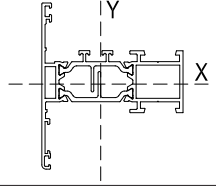
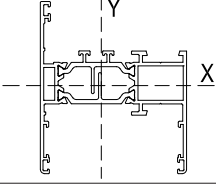
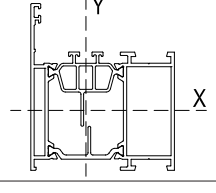
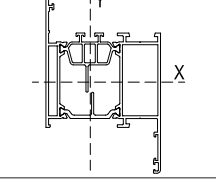
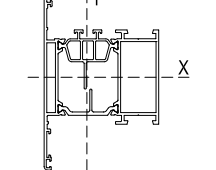

Profilati ed Inerzie

|  SAGOMA | ARTICOLO | INERZIA | MODULO | DESCRIZIONE |
|---|---------------|-----------------|-----------------|---|
| | PESO (Kg/m) | cm ⁴ | cm ³ | |
|  | 665000 | J_x 7.7 | W_x 1.9 | TELAIO Z TUBOLARITÀ STANDARD (PAG. 4.2) |
| | 1.311 | J_y 20.9 | W_y 6.2 | |
|  | 665001 | J_x 4.6 | W_x 1.4 | TELAIO L TUBOLARITÀ STANDARD (PAG. 4.2) |
| | 1.184 | J_y 17.1 | W_y 4.7 | |
|  | 665002 | J_x 8.3 | W_x 2.3 | ANTA Z SGUSCIATA TUBOLARITÀ STANDARD (PAG. 4.14) |
| | 1.466 | J_y 26.9 | W_y 6.9 | |
|  | 665003 | J_x 6.0 | W_x 1.7 | RIPORTO CENTRALE PIANO (PAG. 4.32) |
| | 1.34 | J_y 21.2 | W_y 5.1 | |
|  | 665004 | J_x 7.7 | W_x 1.9 | TELAIO T TUBOLARITÀ STANDARD (PAG. 4.3) |
| | 1.32 | J_y 19.4 | W_y 5.0 | |
|  | 665005 | J_x 10.4 | W_x 2.7 | TELAIO H TUBOLARITÀ STANDARD (PAG. 4.3) |
| | 1.447 | J_y 23.8 | W_y 6.6 | |
|  | 665006 | J_x 20.0 | W_x 4.4 | TELAIO L TUBOLARITÀ MAGGIORATA (PAG. 4.6) |
| | 1.635 | J_y 24.2 | W_y 6.6 | |
|  | 665007 | J_x 26.2 | W_x 4.9 | TELAIO Z TUBOLARITÀ MAGGIORATA (PAG. 4.6) |
| | 1.735 | J_y 28.1 | W_y 8.2 | |
|  | 665008 | J_x 26.3 | W_x 4.9 | TELAIO T TUBOLARITÀ MAGGIORATA (PAG. 4.7) |
| | 1.770 | J_y 26.6 | W_y 6.9 | |

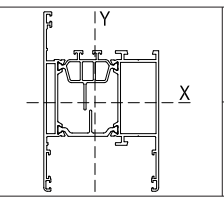
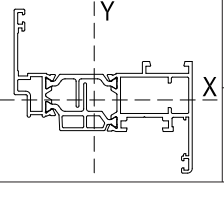
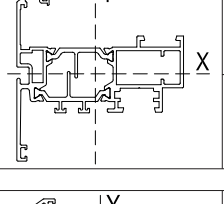
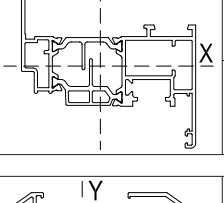
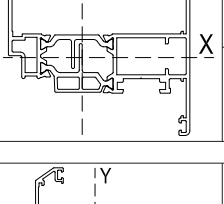
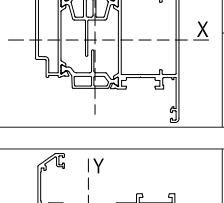
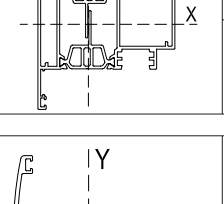
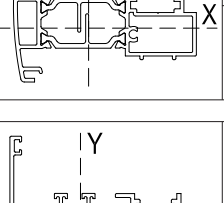
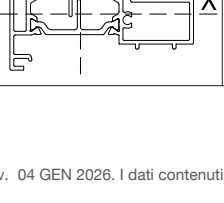
|  SAGOMA | ARTICOLO | INERZIA | MODULO | DESCRIZIONE |
|---|---------------|-----------------|-----------------|---|
| | PESO (Kg/m) | cm ⁴ | cm ³ | |
|  | 665009 | J_x 31.8 | W_x 5.9 | TELAIO H TUBOLARITÀ MAGGIORATA (PAG. 4.7) |
| | 1.87 | J_y 31.0 | W_y 8.6 | |
|  | 665010 | J_x 7.0 | W_x 1.9 | ANTA Z PIANA TUBOLARITÀ STANDARD (PAG. 4.15) |
| | 1.416 | J_y 26.5 | W_y 6.9 | |
|  | 665011 | J_x 11.7 | W_x 3.0 | ANTA T SGUSCIATA TUBOLARITÀ STANDARD (PAG. 4.16) |
| | 1.663 | J_y 28.9 | W_y 6.3 | |
|  | 665012 | J_x 11.5 | W_x 3.0 | ANTA Z SGUSCIATA PISTA 16 TUBOLARITÀ STANDARD (PAG. 4.19) |
| | 1.642 | J_y 29.6 | W_y 7.6 | |
|  | 665013 | J_x 12.1 | W_x 3.4 | ANTA Z SGUSCIATA VETRO A INFILLO TUBOLARITÀ STANDARD (PAG. 4.17) |
| | 1.628 | J_y 31.1 | W_y 8.1 | |
|  | 665014 | J_x 28.6 | W_x 5.9 | ANTA Z SGUSCIATA TUBOLARITÀ MAGGIORATA (PAG. 4.22) |
| | 1.943 | J_y 35.6 | W_y 9.0 | |
|  | 665016 | J_x 30.8 | W_x 6.2 | ANTA SGUSCIATA APERTURA A BILICO (PAG. 4.28) |
| | 2.124 | J_y 35.7 | W_y 7.9 | |
|  | 665017 | J_x 6.7 | W_x 1.8 | RIPORTO CENTRALE ARROTONDATO (PAG. 4.32) |
| | 1.393 | J_y 23.0 | W_y 5.3 | |
|  | 665018 | J_x 6.1 | W_x 1.7 | RIPORTO CENTRALE PIANO PISTA 16 (PAG. 4.33) |
| | 1.348 | J_y 21.3 | W_y 5.1 | |

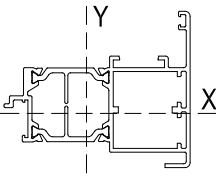
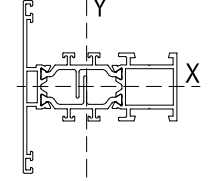
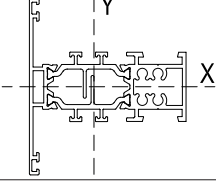
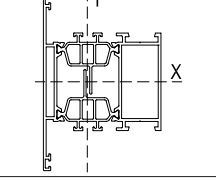
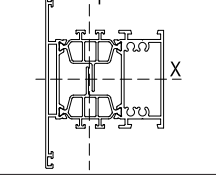
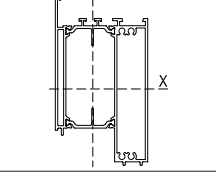
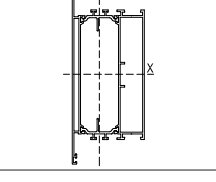
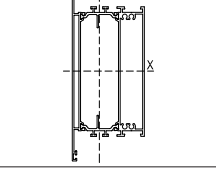
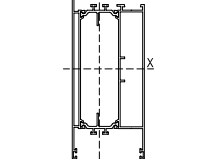
|  SAGOMA | ARTICOLO | INERZIA | MODULO | DESCRIZIONE |
|---|---------------|-----------------|-----------------|---|
| | PESO (Kg/m) | cm ⁴ | cm ³ | |
|  | 665019 | J_x 8.2 | W_x 2.3 | RIPORTO BILICO (PAG. 4.34) |
| | 1.353 | J_y 22.2 | W_y 5.6 | |
|  | 665020 | J_x 6.8 | W_x 1.9 | TRAVERSO CON CAVALOTTI TUBOLARITÁ STANDARD (PAG. 4.36) |
| | 1.294 | J_y 18.5 | W_y 4.9 | |
|  | 665021 | J_x 7.0 | W_x 1.9 | TRAVERSO CON VITI TUBOLARITÁ STANDARD (PAG. 4.36) |
| | 1.463 | J_y 20.7 | W_y 5.8 | |
|  | 665022 | J_x 25.1 | W_x 5.2 | TRAVERSO CON CAVALOTTI TUBOLARITÁ MAGGIORATA (PAG. 4.37) |
| | 1.791 | J_y 25.6 | W_y 6.8 | |
|  | 665023 | J_x 26.6 | W_x 5.4 | TRAVERSO CON VITI TUBOLARITÁ MAGGIORATA (PAG. 4.37) |
| | 1.961 | J_y 27.7 | W_y 7.7 | |
|  | 665024 | J_x 81.4 | W_x 12.7 | ZOCCOLO RIPORTATO (PAG. 4.39) |
| | 2.403 | J_y 37.0 | W_y 11.3 | |
|  | 665025 | J_x 152.9 | W_x 19.1 | FASCIA CON CAVALLOTTI (PAG. 4.41) |
| | 2.91 | J_y 44.1 | W_y 11.7 | |
|  | 665026 | J_x 163.3 | W_x 20.4 | FASCIA CON VITI (PAG. 4.42) |
| | 2.936 | J_y 45.3 | W_y 12.6 | |
|  | 665027 | J_x 156.8 | W_x 19.5 | ZOCCOLO CON CAVALLOTTI (PAG. 4.43) |
| | 2.915 | J_y 46.3 | W_y 12.8 | |

| | SAGOMA | ARTICOLO | INERZIA | MODULO | DESCRIZIONE |
|--|---------------|-------------|-----------------|--|-------------|
| | | PESO (Kg/m) | cm ⁴ | cm ³ | |
| | 665028 | J_x | W_x | ZOCOLO CON VITI (PAG. 4.44) | |
| | 3.019 | 167.3 | 20.9 | | |
| | | J_y | W_y | | |
| | | 48.0 | 13.6 | | |
| | 665029 | J_x | W_x | PILASTRINO (PAG. 4.54) | |
| | 2.684 | 33.9 | 7.0 | | |
| | | J_y | W_y | | |
| | | 110.6 | 17.5 | | |
| | 665030 | J_x | W_x | SEMIPILASTRINO (PAG. 4.54) | |
| | 1.838 | 5.9 | 1.8 | | |
| | | J_y | W_y | | |
| | | 72.4 | 10.8 | | |
| | 665031 | J_x | W_x | CIELINO MONOBLOCCO (PAG. 4.55) | |
| | 1.628 | 5.4 | 1.6 | | |
| | | J_y | W_y | | |
| | | 38.5 | 7.5 | | |
| | 665032 | J_x | W_x | SPALLA MONOBLOCCO (PAG. 4.56) | |
| | 2.359 | 62.8 | 7.3 | | |
| | | J_y | W_y | | |
| | | 119.6 | 14.8 | | |
| | 665033 | J_x | W_x | COMPENSATORE (PAG. 4.12) | |
| | 1.292 | | | | |
| | | J_y | W_y | | |
| | | | | | |
| | 665034 | J_x | W_x | SOGLIA RIBASSATA (PAG. 4.13) | |
| | 0.737 | | | | |
| | | J_y | W_y | | |
| | | | | | |
| | 665035 | J_x | W_x | PROFILATO CAPANNONI (PAG. 4.59) | |
| | 2.173 | 22.1 | 4.6 | | |
| | | J_y | W_y | | |
| | | 56.7 | 8.6 | | |
| | 665036 | J_x | W_x | GIUNZIONE CON PLATHINA 78S (PAG. 4.67) | |
| | 1.598 | 8.4 | 3.1 | | |
| | | J_y | W_y | | |
| | | 31.1 | 7.3 | | |

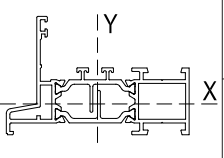
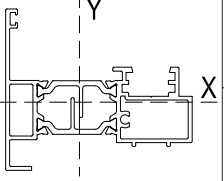
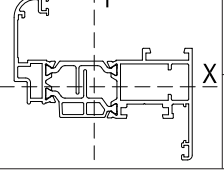
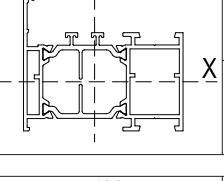
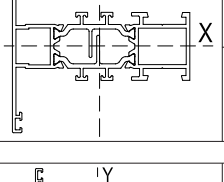
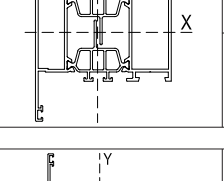
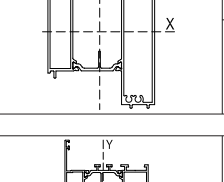
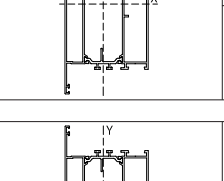
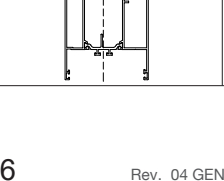
|  SAGOMA | ARTICOLO | INERZIA | MODULO | DESCRIZIONE |
|---|---------------|-----------------|-----------------|--|
| | PESO (Kg/m) | cm ⁴ | cm ³ | |
|  | 665037 | J_x 4.8 | W_x 1.4 | GIUNZIONE CON PLATHINA 78S E PLATHINA 78AS (PAG. 4.67) |
| | 1.291 | J_y 21.0 | W_y 5.4 | |
|  | 665038 | J_x 5.8 | W_x 1.6 | RIPORTO CENTRALE APERTURA DOPPIA BATTUTA (PAG. 4.34) |
| | 1.323 | J_y 20.1 | W_y 4.9 | |
|  | 665039 | J_x 8.5 | W_x 2.4 | ANTA Z RAGGIATA TUBOLARITÀ STANDARD (PAG. 4.14) |
| | 1.470 | J_y 27.1 | W_y 6.9 | |
|  | 665040 | J_x 9.9 | W_x 2.5 | TELAIO L SEMI-MAGGIORATO (PAG. 4.8) |
| | 1.394 | J_y 20.8 | W_y 5.7 | |
|  | 665041 | J_x 7.0 | W_x 1.9 | TRAVERSO CON CAVALOTTI TUBOLARITÀ STANDARD PER ANTA PIANA (PAG. 4.46) |
| | 1.378 | J_y 25.2 | W_y 6.1 | |
|  | 665042 | J_x 26.1 | W_x 5.4 | TRAVERSO CON CAVALOTTI TUBOLARITÀ MAGGIORATA PER ANTA PIANA (PAG. 4.47) |
| | 1.875 | J_y 33.9 | W_y 8.3 | |
|  | 665043 | J_x 84.1 | W_x 13.1 | ZOCCOLO RIPORTATO PER ANTA PIANA (PAG. 4.48) |
| | 2.509 | J_y 47.5 | W_y 12.2 | |
|  | 665044 | J_x 158.7 | W_x 19.8 | FASCIA CON CAVALLOTTI PER ANTA PIANA (PAG. 4.49) |
| | 3.021 | J_y 56.0 | W_y 14.0 | |
|  | 665045 | J_x 162.8 | W_x 20.3 | ZOCCOLO CON CAVALLOTTI PER ANTA PIANA (PAG. 4.51) |
| | 3.026 | J_y 59.3 | W_y 15.2 | |

| | SAGOMA | ARTICOLO | INERZIA | MODULO | DESCRIZIONE |
|--|---------------|-------------|-----------------|--|-------------|
| | | PESO (Kg/m) | cm ⁴ | cm ³ | |
| | 665050 | J_x | W_x | ANTA Z STORICA TUBOLARITÀ STANDARD (PAG. 4.15) | |
| | 1.477 | 8.7 | 2.4 | | |
| | 665051 | J_y | W_y | ANTA Z SGUSCIATA PISTA 16 TUBOLARITÀ MAGGIORATA (PAG. 4.23) | |
| | 2.163 | 36.2 | 7.0 | | |
| | 665052 | J_x | W_x | TRAVERSO CON VITI TUBOLARITÀ STANDARD PER ANTA PIANA (PAG. 4.46) | |
| | 1.547 | 7.1 | 2.0 | | |
| | 665053 | J_y | W_y | TRAVERSO CON VITI TUBOLARITÀ MAGGIORATA PER ANTA PIANA (PAG. 4.47) | |
| | 2.045 | 27.5 | 5.6 | | |
| | 665054 | J_x | W_x | FASCIA CON VITI TUBOLARITÀ MAGGIORATA PER ANTA PIANA (PAG. 4.50) | |
| | 3.047 | 27.5 | 5.6 | | |
| | 665055 | J_y | W_y | ZOCCOLO CON VITI TUBOLARITÀ MAGGIORATA PER ANTA PIANA (PAG. 4.52) | |
| | 3.130 | 173.5 | 21.6 | | |
| | 665056 | J_x | W_x | ANTA Z ARROTONDATA PISTA 16 TUBOLARITÀ STANDARD (PAG. 4.20) | |
| | 1.646 | 11.7 | 3.0 | | |
| | 665057 | J_y | W_y | ANTA Z ARROTONDATA TUBOLARITÀ MAGGIORATA (PAG. 4.22) | |
| | 1.946 | 28.9 | 5.9 | | |
| | 665058 | J_x | W_x | ANTA Z PIANA TUBOLARITÀ MAGGIORATA (PAG. 4.23) | |
| | 1.893 | 25.9 | 5.2 | | |
| | | J_y | W_y | | |
| | | 35.1 | 9.0 | | |

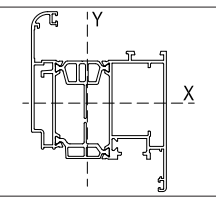
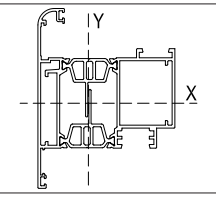
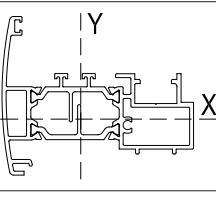
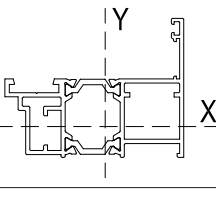
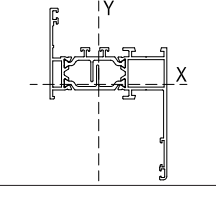
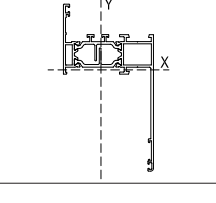
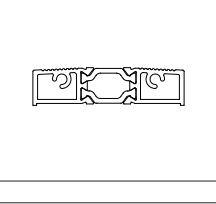
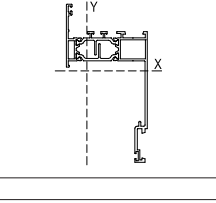
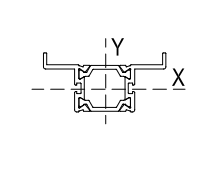

|  SAGOMA | ARTICOLO | INERZIA | MODULO | DESCRIZIONE |
|---|---------------|-----------------|-----------------|--|
| | PESO (Kg/m) | cm ⁴ | cm ³ | |
|  | 665059 | J_x 36.6 | W_x 7.1 | ANTA Z ARROTONDATA PISTA 16 TUBULARITÀ MAGGIORATA (PAG. 4.24) |
| | 2.167 | J_y 39.0 | W_y 9.8 | |
|  | 665064 | J_x 31.1 | W_x 6.3 | ANTA ARROTONDATA APERTURA A BILICO (PAG. 4.28) |
| | 2.218 | J_y 35.8 | W_y 8.0 | |
|  | 665065 | J_x 6.7 | W_x 1.9 | RIPORTO ARROTONDATO CENTRALE PISTA 16 (PAG. 4.33) |
| | 1.401 | J_y 23.2 | W_y 5.4 | |
|  | 665066 | J_x 5.2 | W_x 1.6 | RIPORTO APERTURA ESTERNA INSERIMENTO IN VETRINA (PAG. 4.36) |
| | 1.241 | J_y 13.7 | W_y 3.9 | |
|  | 665067 | J_x 13.7 | W_x 2.4 | TELAIO L TUBULARITÀ STANDARD ALETTA DA 45 mm (PAG. 4.4) |
| | 1.406 | J_y 23.5 | W_y 7.1 | |
|  | 665068 | J_x 29.1 | W_x 3.8 | TELAIO L TUBULARITÀ STANDARD ALETTA DA 70 mm (PAG. 4.5) |
| | 1.542 | J_y 26.6 | W_y 7.6 | |
|  | 665069 | J_x | W_x | SOGLIA (PAG. 4.12) |
| | 0.935 | J_y | W_y | |
|  | 665078 | J_x 46.5 | W_x 5.9 | SPALLA MONOBLOCCO (PAG. 4.57) |
| | 0.991 | J_y 27.6 | W_y 7.6 | |
|  | 665080 | J_x | W_x | PROFILATO COMPLEMENTARE PER INSERIMENTO IN FACCIATA (PAG. 4.68) |
| | 0.732 | J_y | W_y | |

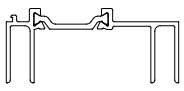
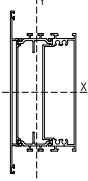
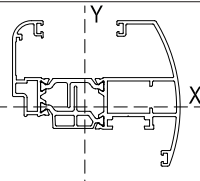
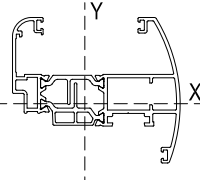
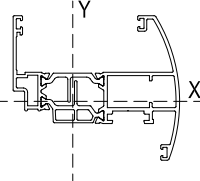
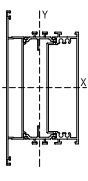
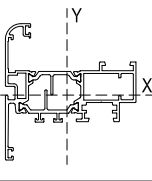
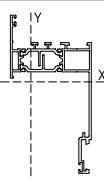
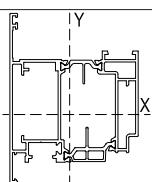



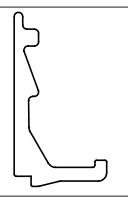
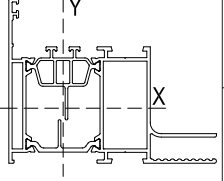
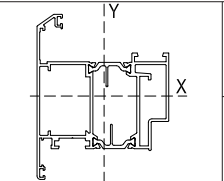
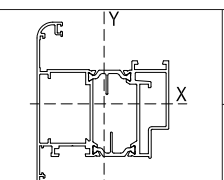
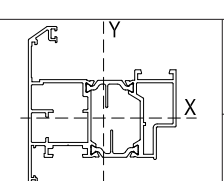
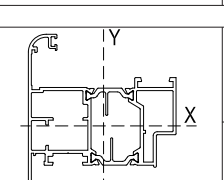
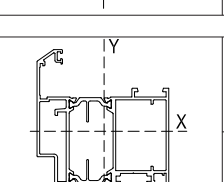
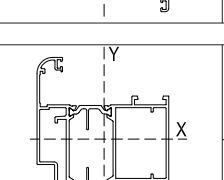
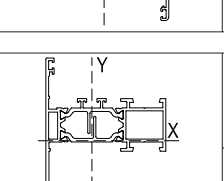
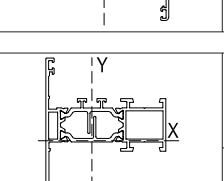

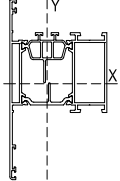
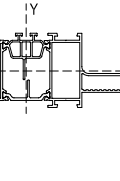
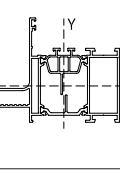
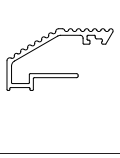
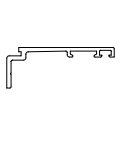
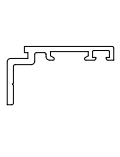

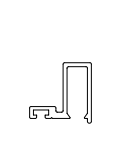
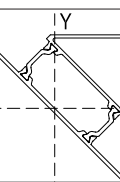
| SAGOMA | ARTICOLO | INERZIA | MODULO | DESCRIZIONE |
|------------|---------------|-----------------|-----------------|--|
| | PESO (Kg/m) | cm ⁴ | cm ³ | |
| | 665081 | J_x 9.9 | W_x 2.5 | ANTA Z PIANA PISTA 16 TUBOLARITÀ STANDARD (PAG. 4.19) |
| | 1.593 | J_y 29.3 | W_y 7.6 | |
| | 665084 | J_x 34.3 | W_x 6.6 | ANTA Z PINA PISTA 16 TUBOLARITÀ MAGGIORATA (PAG. 4.24) |
| | 2.113 | J_y 39.3 | W_y 9.8 | |
| | 665085 | J_x 12.6 | W_x 3.5 | ANTA Z ARROTONDATA VETRO A INFILO TUBOLARITÀ STANDARD (PAG. 4.18) |
| | 1.636 | J_y 31.5 | W_y 8.2 | |
| | 665086 | J_x 1.5 | W_x 1.1 | PROFILATO PER GIUNZIONE TELAI A L (PAG. 4.68) |
| | 0.948 | J_y 12.3 | W_y 3.7 | |
| | 665087 | J_x | W_x | SOGLIA RIBASSATA (PAG. 4.13) |
| | 0.766 | J_y | W_y | |
| | 665092 | J_x 27.0 | W_x 5.4 | PROFILATO CAPANNONI (PAG. 4.60) |
| | 2.173 | J_y 57.1 | W_y 8.6 | |
| | 665094 | J_x 13.4 | W_x 3.7 | ANTA Z PIANA VETRO A INFILO TUBOLARITÀ STANDARD (PAG. 4.18) |
| | 1.661 | J_y 8.5 | W_y 3.3 | |
| | 665095 | J_x 16.1 | W_x 3.5 | ANTA APERTURA ESTERNA ARROTONDATA DOPPIA BATTUTA TUBOLARITÀ STANDARD (PAG. 4.17) |
| | 1.663 | J_y 31.5 | W_y 7.0 | |
| | 665097 | J_x 29.2 | W_x 10.1 | ZOCCOLO RIPORTATO VETRO INFILO (PAG. 4.40) |
| | 1.987 | J_y 97.0 | W_y 15.0 | |

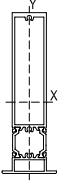
|  SAGOMA | ARTICOLO | INERZIA | MODULO | DESCRIZIONE |
|---|---------------|-----------------|-----------------|---|
| | PESO (Kg/m) | cm ⁴ | cm ³ | |
|  | 665098 | J_x | W_x | PROFILATO PERIMETRALE NASTRI (PAG. 4.5) |
| | 0.722 | J_y | W_y | |
|  | 665099 | J_x 167.3 | W_x 21.0 | FASCIA PER SERRATURE (PAG. 4.45) |
| | 3.099 | J_y 49.7 | W_y 14.0 | |
|  | 665100 | J_x 13.3 | W_x 3.5 | ANTA VETRO INFILLO ANTARES SPAZIO VETRO 35mm (PAG. 4.20) |
| | 1.718 | J_y 34.3 | W_y 8.4 | |
|  | 665101 | J_x 8.5 | W_x 2.4 | ANTA VETRO INFILLO ANTARES SPAZIO VETRO 45mm (PAG. 4.21) |
| | 1.675 | J_y 27.1 | W_y 7.0 | |
|  | 665108 | J_x 10.5 | W_x 2.8 | ANTA VETRO INFILLO ANTARES SPAZIO VETRO 45mm (PAG. 4.21) |
| | 1.621 | J_y 33.6 | W_y 8.4 | |
|  | 665109 | J_x 177.8 | W_x 22.4 | FASCIA PER SERRATURE ANTA PIANA (PAG. 4.45) |
| | 3.010 | J_y 60.9 | W_y 15.4 | |
|  | 665110 | J_x 11.7 | W_x 2.9 | ANTA A T LINEA ARROTONDATA (PAG. 4.16) |
| | 1.667 | J_y 28.7 | W_y 6.3 | |
|  | 665112 | J_x 29.4 | W_x 5.6 | SPALLA MONOBLOCCO (PAG. 4.63) |
| | 2.039 | J_y 44.8 | W_y 7.0 | |
|  | 665113 | J_x 40.6 | W_x 7.7 | ANTA APERTURA ESTERNA MAGGIORATA LINE PIANA P. 16 DOPPIA BATTUTA (PAG. 4.29) |
| | 2.189 | J_y 41.3 | W_y 13.3 | |

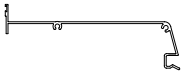

| SAGOMA | ARTICOLO | INERZIA | MODULO | DESCRIZIONE |
|------------|---------------|-----------------|-----------------|---|
| | PESO (Kg/m) | cm ⁴ | cm ³ | |
| | 665114 | J_x 30.1 | W_x 5.6 | ANTA PIANA APERTURA BILICO (PAG. 4.30) |
| | 2.073 | J_y 35.7 | W_y 10.5 | |
| | 665115 | J_x 14.7 | W_x 2.8 | TELAIO SEMI-MAGGIORATO FISSO A T (PAG. 4.9) |
| | 1.532 | J_y 23.1 | W_y 6.3 | |
| | 665116 | J_x 14 | W_x 2.8 | TELAIO SEMI-MAGGIORATO FISSO A Z (PAG. 4.8) |
| | 1.522 | J_y 24.5 | W_y 7 | |
| | 665117 | J_x 42 | W_x 7.7 | ANTA MAGGIORATA PIANA P.16 (PAG. 4.29) |
| | 2.308 | J_y 41.3 | W_y 10.5 | |
| | 665119 | J_x 4.6 | W_x 1.4 | RIPORTO (PAG. 4.35) |
| | 1.210 | J_y 17.1 | W_y 4.7 | |
| | 665120 | J_x 13.0 | W_x 2.3 | TELAIO L ANTA A SCOMPARSA (PAG. 4.9) |
| | 1.332 | J_y 19.6 | W_y 5.0 | |
| | 665121 | J_x 8.2 | W_x 2.4 | ANTA A SCOMPARSA (PAG. 4.31) |
| | 1.556 | J_y 22.6 | W_y 5.9 | |
| | 665122 | J_x 2.8 | W_x 1.4 | RIPORTO PER FISSA LATERALE ANTA A SCOMPARSA (PAG. 4.31) |
| | 1.031 | J_y 13.3 | W_y 4.2 | |
| | 665123 | J_x 25.2 | W_x 4.2 | TRAVERSO / MONTANTE PER ANTA A SCOMPARSA (PAG. 4.38) |
| | 1.557 | J_y 22.4 | W_y 5.6 | |

|  SAGOMA | ARTICOLO | INERZIA | MODULO | DESCRIZIONE |
|---|---------------|-----------------|-----------------|---|
| | PESO (Kg/m) | cm ⁴ | cm ³ | |
|  | 665438 | J_x | W_x | FERMAVETRO ANTA A SCOMPARSA (PAG. 4.31) |
| | 0.161 | - | - | |
|  | 665124 | J_x | W_x | TELAIO L CAPANNONI (PAG. 4.61) |
| | 1.904 | 29.4 | 5.6 | |
|  | 665126 | J_y | W_y | ANTA APERTURA ESTERNA MAGGIORATA DOPPIA BATTUTA LINEA SGUSCIATA (PAG. 4.25) |
| | 2.046 | 30.1 | 6.3 | |
|  | 665127 | J_x | W_x | ANTA APERTURA ESTERNA MAGGIORATA DOPPIA BATTUTA LINEA AROTONDATA (PAG. 4.25) |
| | 2.049 | 30.1 | 6.3 | |
|  | 665128 | J_y | W_y | ANTA APERTURA ESTERNA STANDARD DOPPIA BATTUTA LINEA SGUSCIATA (PAG. 4.26) |
| | 1.858 | 18.9 | 4.2 | |
|  | 665129 | J_x | W_x | ANTA APERTURA ESTERNA STANDARD DOPPIA BATTUTA LINEA AROTONDATA (PAG. 4.26) |
| | 1.862 | 18.9 | 4.2 | |
|  | 665130 | J_y | W_y | ANTA APERTURA INTERNA MAGGIORATA DOPPIA BATTUTA LINEA SGUSCIATA (PAG. 4.27) |
| | 2.006 | 31.5 | 7.7 | |
|  | 665131 | J_x | W_x | ANTA APERTURA INTERNA MAGGIORATA DOPPIA BATTUTA LINEA ARROTONDATA (PAG. 4.27) |
| | 2.009 | 28.7 | 6.3 | |
|  | 665132 | J_y | W_y | TELAIO STANDARD FISSO T ALETTA LUNGA DA 45MM (PAG. 4.10) |
| | 1.411 | 14 | 2.8 | |
|  | 665132 | J_x | W_x | TELAIO STANDARD FISSO T ALETTA LUNGA DA 45MM (PAG. 4.10) |
| | 1.411 | 21 | 4.9 | |

|  SAGOMA | ARTICOLO | INERZIA | MODULO | DESCRIZIONE |
|---|---------------|------------------------------|-------------------------------|---|
| | PESO (Kg/m) | cm ⁴ | cm ³ | |
|  | 665133 | <i>J_x</i> 36.4 | <i>W_x</i> 7 | TELAIO MAGGIORATO FISSO T ALETTA LUNGA DA 45MM (PAG. 4.11) |
| | 1.868 | <i>J_y</i> 28.7 | <i>W_y</i> 4.9 | |
|  | 665134 | <i>J_x</i> 38.5 | <i>W_x</i> 5.6 | TELAIO T CAPANNONI ALETTA DA 45MM (PAG. 4.64) |
| | 2.137 | <i>J_y</i> 47.6 | <i>W_y</i> 7.7 | |
|  | 665135 | <i>J_x</i> 21 | <i>W_x</i> 4.2.8 | TELAIO L CAPANNONI (PAG. 4.62) |
| | 1.904 | <i>J_y</i> 36.4 | <i>W_y</i> 7 | |
|  | 665250 | <i>J_x</i> | <i>W_x</i> | PROFILATO COMPLEMENTARE SOGLIA RIBASSATA (PAG. 4.72) |
| | 0.377 | <i>J_y</i> | <i>W_y</i> | |
|  | 665276 | <i>J_x</i> | <i>W_x</i> | COPRIFILO A MURO 40 MM (PAG. 4.69) |
| | 0.306 | <i>J_y</i> | <i>W_y</i> | |
|  | 665277 | <i>J_x</i> | <i>W_x</i> | COPRIFILO A MURO 26 MM (PAG. 4.69) |
| | 0.244 | <i>J_y</i> | <i>W_y</i> | |
|  | 665278 | <i>J_x</i> | <i>W_x</i> | COPRIFILO A MURO 70 MM (PAG. 4.69) |
| | 0.475 | <i>J_y</i> | <i>W_y</i> | |
|  | 665282 | <i>J_x</i> | <i>W_x</i> | GOCCIOLATOIO PER ANTE DOPPIA BATTUTA (PAG. 4.72) |
| | 0.272 | <i>J_y</i> | <i>W_y</i> | |
|  | 61727 | <i>J_x</i> 38.9 | <i>W_x</i> 9.7 | PROFILATO AD ANGOLO 90° (PAG. 4.55) |
| | 2.129 | <i>J_y</i> 38.9 | <i>W_y</i> 9.7 | |

|  SAGOMA | ARTICOLO | INERZIA | MODULO | DESCRIZIONE |
|---|--------------|------------------------------|-----------------------------|--|
| | PESO (Kg/m) | cm ⁴ | cm ³ | |
|  | 55590 | <i>J_x</i> 11.8 | <i>W_x</i> 3.4 | MONTANTE UNIVERSALE (PAG. 4.66) |
| | 2.089 | <i>J_y</i> 4.6 | <i>W_y</i> 1.4 | |
|  | 1234 | <i>J_x</i> | <i>W_x</i> | COPRICAVA MONOBLOCCO (PAG. 4.56) |
| | 0.150 | <i>J_y</i> | <i>W_y</i> | |
|  | 1184 | <i>J_x</i> | <i>W_x</i> | PROFILATO PER CASSONETTO MONOBLOCCO (PAG. 4.58) |
| | 1.165 | <i>J_y</i> | <i>W_y</i> | |
|  | 1185 | <i>J_x</i> | <i>W_x</i> | PROFILATO PER CASSONETTO MONOBLOCCO (PAG. 4.58) |
| | 1.250 | <i>J_y</i> | <i>W_y</i> | |
|  | 6405 | <i>J_x</i> | <i>W_x</i> | ASTINA DI COLLEGAMENTO (PAG. 4.74) |
| | 0.159 | <i>J_y</i> | <i>W_y</i> | |
|  | 40269 | <i>J_x</i> | <i>W_x</i> | PROFILATO GOCCIOLATOIO (PAG. 4.72) |
| | 0.141 | <i>J_y</i> | <i>W_y</i> | |
|  | 40272 | <i>J_x</i> | <i>W_x</i> | PROFILATO MONTANTE PER INGLESINA (PAG. 4.71) |
| | 0.184 | <i>J_y</i> | <i>W_y</i> | |
|  | 40273 | <i>J_x</i> | <i>W_x</i> | PROFILATO TRAVERSO PER INGLESINA (PAG. 4.71) |
| | 0.178 | <i>J_y</i> | <i>W_y</i> | |
|  | 40281 | <i>J_x</i> | <i>W_x</i> | PROFILATO COMPLEMENTARE APERTURA ESTERNA (PAG. 4.74) |
| | 0.156 | <i>J_y</i> | <i>W_y</i> | |

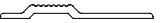
| SAGOMA | ARTICOLO | INERZIA | MODULO | DESCRIZIONE |
|------------|--------------|----------------------|----------------------|--|
| | PESO (Kg/m) | cm ⁴ | cm ³ | |
| | 40282 | <i>J_x</i> | <i>W_x</i> | PROFILATO SOTTOPORTA (PAG. 4.73) |
| | 0.375 | <i>J_y</i> | <i>W_y</i> | |
| | 40291 | <i>J_x</i> | <i>W_x</i> | IMBOTTE DA 62 mm (PAG. 4.65) |
| | 0.641 | <i>J_y</i> | <i>W_y</i> | |
| | 40292 | <i>J_x</i> | <i>W_x</i> | IMBOTTE DA 92 mm (PAG. 4.65) |
| | 0.770 | <i>J_y</i> | <i>W_y</i> | |
| | 40293 | <i>J_x</i> | <i>W_x</i> | IMBOTTE DA 129.5 mm (PAG. 4.65) |
| | 0.985 | <i>J_y</i> | <i>W_y</i> | |
| | 40319 | <i>J_x</i> | <i>W_x</i> | PROFILATO BASE PER COPRIFILI A SCATTO (PAG. 4.71) |
| | 0.370 | <i>J_y</i> | <i>W_y</i> | |
| | 40320 | <i>J_x</i> | <i>W_x</i> | COPRIFILO A SCATTO 40 MM (PAG. 4.70) |
| | 0.233 | <i>J_y</i> | <i>W_y</i> | |
| | 40321 | <i>J_x</i> | <i>W_x</i> | COPRIFILO A SCATTO 55 MM (PAG. 4.70) |
| | 0.312 | <i>J_y</i> | <i>W_y</i> | |
| | 40322 | <i>J_x</i> | <i>W_x</i> | COPRIFILO A SCATTO 70 MM (PAG. 4.70) |
| | 0.390 | <i>J_y</i> | <i>W_y</i> | |
| | 50052 | <i>J_x</i> | <i>W_x</i> | PROFILATO PORTA SPAZZOLINO (PAG. 4.73) |
| | 0.175 | <i>J_y</i> | <i>W_y</i> | |

|  SAGOMA | ARTICOLO | INERZIA | MODULO | DESCRIZIONE |
|---|--------------------|-----------------------|-----------------------|--|
| | <i>PESO (Kg/m)</i> | <i>cm⁴</i> | <i>cm³</i> | |
|  | 72531 | <i>J_x</i> | <i>W_x</i> | SOGLIA PIATTA (PAG. 4.73) |
| | 0.226 | <i>J_y</i> | <i>W_y</i> | |
|  | 72524 | <i>J_x</i> | <i>W_x</i> | MANINA SUPPORTO VETRO PER ANTA A SCOMPARSA ART. 665047 (PAG. 4.74) |
| | 0.257 | <i>J_y</i> | <i>W_y</i> | |

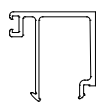
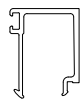
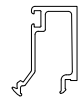
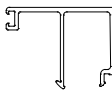
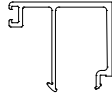
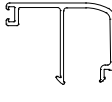
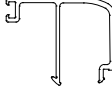
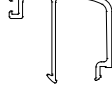
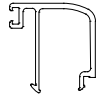
|  SAGOMA | ARTICOLO | INERZIA | MODULO | DESCRIZIONE |
|---|--------------|----------------------|----------------------|--|
| | PESO (Kg/m) | cm ⁴ | cm ³ | |
|  | 40007 | <i>J_x</i> | <i>W_x</i> | FERMAVETRO PIANO DA 25,5 MM (PAG. 4.75) |
| | 0.318 | <i>J_y</i> | <i>W_y</i> | |
|  | 40029 | <i>J_x</i> | <i>W_x</i> | FERMAVETRO PIANO DA 20,5 MM (PAG. 4.75) |
| | 0.283 | <i>J_y</i> | <i>W_y</i> | |
|  | 40030 | <i>J_x</i> | <i>W_x</i> | FERMAVETRO PIANO DA 13,5 MM (PAG. 4.75) |
| | 0.263 | <i>J_y</i> | <i>W_y</i> | |
|  | 40037 | <i>J_x</i> | <i>W_x</i> | FERMAVETRO PIANO DA 35,5 MM (PAG. 4.76) |
| | 0.359 | <i>J_y</i> | <i>W_y</i> | |
|  | 40039 | <i>J_x</i> | <i>W_x</i> | FERMAVETRO PIANO DA 30,5 MM (PAG. 4.76) |
| | 0.339 | <i>J_y</i> | <i>W_y</i> | |
|  | 40077 | <i>J_x</i> | <i>W_x</i> | FERMAVETRO ARROTONDATO DA 35,5 MM (PAG. 4.81) |
| | 0.352 | <i>J_y</i> | <i>W_y</i> | |
|  | 40078 | <i>J_x</i> | <i>W_x</i> | FERMAVETRO ARROTONDATO DA 33 MM (PAG. 4.80) |
| | 0.342 | <i>J_y</i> | <i>W_y</i> | |
|  | 40079 | <i>J_x</i> | <i>W_x</i> | FERMAVETRO ARROTONDATO DA 30,5 MM (PAG. 4.80) |
| | 0.332 | <i>J_y</i> | <i>W_y</i> | |
|  | 40080 | <i>J_x</i> | <i>W_x</i> | FERMAVETRO ARROTONDATO DA 25,5 MM (PAG. 4.80) |
| | 0.312 | <i>J_y</i> | <i>W_y</i> | |

|  SAGOMA | ARTICOLO | INERZIA | MODULO | DESCRIZIONE |
|---|--------------|-----------------|-----------------|--|
| | PESO (Kg/m) | cm ⁴ | cm ³ | |
|  | 40081 | <i>Jx</i> | <i>Wx</i> | FERMAVETRO ARROTONDATO DA 23,5 MM (PAG. 4.80) |
| | 0.293 | <i>Jy</i> | <i>Wy</i> | |
|  | 40082 | <i>Jx</i> | <i>Wx</i> | FERMAVETRO ARROTONDATO DA 20,5 MM (PAG. 4.80) |
| | 0.274 | <i>Jy</i> | <i>Wy</i> | |
|  | 40083 | <i>Jx</i> | <i>Wx</i> | FERMAVETRO ARROTONDATO DA 13,5 MM (PAG. 4.80) |
| | 0.252 | <i>Jy</i> | <i>Wy</i> | |
|  | 40085 | <i>Jx</i> | <i>Wx</i> | FERMAVETRO PIANO DA 5,5 MM (PAG. 4.75) |
| | 0.210 | <i>Jy</i> | <i>Wy</i> | |
|  | 40086 | <i>Jx</i> | <i>Wx</i> | FERMAPANNELLO DA 2 MM (PAG. 4.75) |
| | 0.178 | <i>Jy</i> | <i>Wy</i> | |
|  | 40087 | <i>Jx</i> | <i>Wx</i> | FERMAVETRO PIANO DA 23,5 MM (PAG. 4.75) |
| | 0.303 | <i>Jy</i> | <i>Wy</i> | |
|  | 40089 | <i>Jx</i> | <i>Wx</i> | FERMAVETRO CON CLIP DA 35,5 MM (PAG. 4.78) |
| | 0.348 | <i>Jy</i> | <i>Wy</i> | |
|  | 40090 | <i>Jx</i> | <i>Wx</i> | FERMAVETRO CON CLIP DA 33 MM (PAG. 4.78) |
| | 0.336 | <i>Jy</i> | <i>Wy</i> | |
|  | 40091 | <i>Jx</i> | <i>Wx</i> | FERMAVETRO CON CLIP DA 30,5 MM (PAG. 4.78) |
| | 0.324 | <i>Jy</i> | <i>Wy</i> | |

|  SAGOMA | ARTICOLO | INERZIA | MODULO | DESCRIZIONE |
|---|--------------|----------------------|----------------------|---|
| | PESO (Kg/m) | cm ⁴ | cm ³ | |
|  | 40092 | <i>J_x</i> | <i>W_x</i> | FERMAVETRO CON CLIP DA 25,5 MM (PAG. 4.77) |
| | 0.291 | <i>J_y</i> | <i>W_y</i> | |
|  | 40093 | <i>J_x</i> | <i>W_x</i> | FERMAVETRO CON CLIP DA 23,5 MM (PAG. 4.77) |
| | 0.282 | <i>J_y</i> | <i>W_y</i> | |
|  | 40094 | <i>J_x</i> | <i>W_x</i> | FERMAVETRO CON CLIP DA 20,5 MM (PAG. 4.77) |
| | 0.268 | <i>J_y</i> | <i>W_y</i> | |
|  | 40095 | <i>J_x</i> | <i>W_x</i> | FERMAVETRO CON CLIP DA 13,5 MM (PAG. 4.77) |
| | 0.236 | <i>J_y</i> | <i>W_y</i> | |
|  | 40096 | <i>J_x</i> | <i>W_x</i> | FERMAVETRO CON CLIP DA 10,5 MM (PAG. 4.77) |
| | 0.221 | <i>J_y</i> | <i>W_y</i> | |
|  | 40097 | <i>J_x</i> | <i>W_x</i> | FERMAVETRO CON CLIP DA 5,5 MM (PAG. 4.77) |
| | 0.199 | <i>J_y</i> | <i>W_y</i> | |
|  | 40098 | <i>J_x</i> | <i>W_x</i> | FERMAPANNELLO CON CLIP DA 2 MM (PAG. 4.77) |
| | 0.169 | <i>J_y</i> | <i>W_y</i> | |
|  | 40111 | <i>J_x</i> | <i>W_x</i> | FERMAVETRO PIANO DA 33 MM (PAG. 4.76) |
| | 0.347 | <i>J_y</i> | <i>W_y</i> | |
|  | 40185 | <i>J_x</i> | <i>W_x</i> | FERMAVETRO PIANO DA 17,5 MM (PAG. 4.75) |
| | 0.280 | <i>J_y</i> | <i>W_y</i> | |

|  SAGOMA | ARTICOLO | INERZIA | MODULO | DESCRIZIONE |
|---|--------------|----------------------|----------------------|--|
| | PESO (Kg/m) | cm ⁴ | cm ³ | |
|  | 40186 | <i>J_x</i> | <i>W_x</i> | FERMAVETRO ARROTONDATO DA 17,5 MM (PAG. 4.80) |
| | 0.272 | <i>J_y</i> | <i>W_y</i> | |
|  | 40187 | <i>J_x</i> | <i>W_x</i> | FERMAVETRO CON CLIP DA 17,5 MM (PAG. 4.77) |
| | 0.254 | <i>J_y</i> | <i>W_y</i> | |
|  | 40216 | <i>J_x</i> | <i>W_x</i> | FERMAVETRO ARROTONDATO DA 15 MM (PAG. 4.80) |
| | 0.259 | <i>J_y</i> | <i>W_y</i> | |
|  | 40217 | <i>J_x</i> | <i>W_x</i> | FERMAVETRO PIANO DA 15 MM (PAG. 4.75) |
| | 0.267 | <i>J_y</i> | <i>W_y</i> | |
|  | 40218 | <i>J_x</i> | <i>W_x</i> | FERMAVETRO CON CLIP DA 15 MM (PAG. 4.77) |
| | 0.243 | <i>J_y</i> | <i>W_y</i> | |
|  | 40225 | <i>J_x</i> | <i>W_x</i> | FERMAVETRO ARROTONDATO CON SCURETTO DA 13,5 MM (PAG. 4.81) |
| | 0.261 | <i>J_y</i> | <i>W_y</i> | |
|  | 40226 | <i>J_x</i> | <i>W_x</i> | FERMAVETRO ARROTONDATO CON SCURETTO DA 20,5 MM (PAG. 4.81) |
| | 0.270 | <i>J_y</i> | <i>W_y</i> | |
|  | 40227 | <i>J_x</i> | <i>W_x</i> | FERMAVETRO ARROTONDATO CON SCURETTO DA 30,5 MM (PAG. 4.81) |
| | 0.341 | <i>J_y</i> | <i>W_y</i> | |
|  | 40228 | <i>J_x</i> | <i>W_x</i> | FERMAVETRO ARROTONDATO CON SCURETTO DA 17,5 MM (PAG. 4.81) |
| | 0.278 | <i>J_y</i> | <i>W_y</i> | |

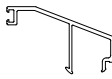
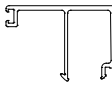
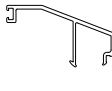
|  SAGOMA | ARTICOLO | INERZIA | MODULO | DESCRIZIONE |
|---|--------------|----------------------|----------------------|---|
| | PESO (Kg/m) | cm ⁴ | cm ³ | |
|  | 40247 | <i>J_x</i> | <i>W_x</i> | FERMAVETRO ARROTONDATO DA 9,5 MM (PAG. 4.80) |
| | 0.229 | <i>J_y</i> | <i>W_y</i> | |
|  | 40249 | <i>J_x</i> | <i>W_x</i> | FERMAVETRO PIANO DA 9,5 MM (PAG. 4.75) |
| | 0.242 | <i>J_y</i> | <i>W_y</i> | |
|  | 40261 | <i>J_x</i> | <i>W_x</i> | FERMAVETRO DESIGN DA 42.5 MM (PAG. 4.82) |
| | 0.327 | <i>J_y</i> | <i>W_y</i> | |
|  | 40262 | <i>J_x</i> | <i>W_x</i> | FERMAVETRO DESIGN DA 34.5 MM (PAG. 4.82) |
| | 0.302 | <i>J_y</i> | <i>W_y</i> | |
|  | 40274 | <i>J_x</i> | <i>W_x</i> | FERMAVETRO DESIGN DA 33 MM (PAG. 4.82) |
| | 0.298 | <i>J_y</i> | <i>W_y</i> | |
|  | 40275 | <i>J_x</i> | <i>W_x</i> | FERMAVETRO PIANO DA 38.5 MM (PAG. 4.76) |
| | 0.379 | <i>J_y</i> | <i>W_y</i> | |
|  | 40276 | <i>J_x</i> | <i>W_x</i> | FERMAVETRO DESIGN DA 38.5 MM (PAG. 4.82) |
| | 0.330 | <i>J_y</i> | <i>W_y</i> | |
|  | 40277 | <i>J_x</i> | <i>W_x</i> | FERMAVETRO PIANO DA 46.5 MM (PAG. 4.76) |
| | 0.414 | <i>J_y</i> | <i>W_y</i> | |
|  | 40278 | <i>J_x</i> | <i>W_x</i> | FERMAVETRO DESIGN DA 46.5 MM (PAG. 4.82) |
| | 0.357 | <i>J_y</i> | <i>W_y</i> | |

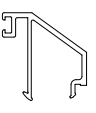
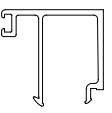
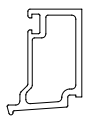
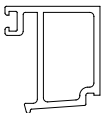
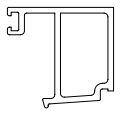
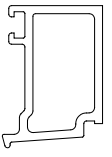
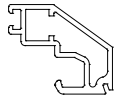
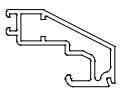
|  SAGOMA | ARTICOLO | INERZIA | MODULO | DESCRIZIONE |
|---|--------------|----------------------|----------------------|--|
| | PESO (Kg/m) | cm ⁴ | cm ³ | |
|  | 40316 | <i>J_x</i> | <i>W_x</i> | FERMAVETRO DESIGN DA 25.5 MM (PAG. 4.82) |
| | 0.283 | <i>J_y</i> | <i>W_y</i> | |
|  | 40326 | <i>J_x</i> | <i>W_x</i> | FERMAVETRO PIANO DA 28 MM (PAG. 4.76) |
| | 0.329 | <i>J_y</i> | <i>W_y</i> | |
|  | 40327 | <i>J_x</i> | <i>W_x</i> | FERMAVETRO TUBOLARE DA 13.5 MM (PAG. 4.79) |
| | 0.311 | <i>J_y</i> | <i>W_y</i> | |
|  | 40328 | <i>J_x</i> | <i>W_x</i> | FERMAVETRO TUBOLARE DA 23.5 MM (PAG. 4.79) |
| | 0.425 | <i>J_y</i> | <i>W_y</i> | |
|  | 40329 | <i>J_x</i> | <i>W_x</i> | FERMAVETRO TUBOLARE DA 28 MM (PAG. 4.79) |
| | 0.405 | <i>J_y</i> | <i>W_y</i> | |
|  | 41258 | <i>J_x</i> | <i>W_x</i> | FERMAVETRO TUBOLARE DA 17.5 MM (PAG. 4.79) |
| | 0.342 | <i>J_y</i> | <i>W_y</i> | |
|  | 41259 | <i>J_x</i> | <i>W_x</i> | FERMAVETRO TUBOLARE DA 20.5 MM (PAG. 4.79) |
| | 0.359 | <i>J_y</i> | <i>W_y</i> | |
|  | 72501 | <i>J_x</i> | <i>W_x</i> | FERMAVETRO DESIGN DA 25.5 MM CON CLIP (PAG. 4.83) |
| | 0.331 | <i>J_y</i> | <i>W_y</i> | |
|  | 72502 | <i>J_x</i> | <i>W_x</i> | FERMAVETRO DESIGN DA 31 MM CON CLIP (PAG. 4.83) |
| | 0.364 | <i>J_y</i> | <i>W_y</i> | |

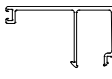
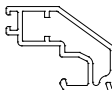
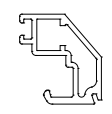
|  SAGOMA | ARTICOLO | INERZIA | MODULO | DESCRIZIONE |
|---|--------------|----------------------|----------------------|--|
| | PESO (Kg/m) | cm ⁴ | cm ³ | |
|  | 72503 | <i>J_x</i> | <i>W_x</i> | FERMAVETRO DESIGN DA 41 MM CON CLIP (PAG. 4.83) |
| | 0.428 | <i>J_y</i> | <i>W_y</i> | |
|  | 72504 | <i>J_x</i> | <i>W_x</i> | FERMAVETRO DESIGN DA 47.5 MM CON CLIP (PAG. 4.83) |
| | 0.492 | <i>J_y</i> | <i>W_y</i> | |
|  | 72505 | <i>J_x</i> | <i>W_x</i> | FERMAVETRO PIANO DA 41 MM (PAG. 4.76) |
| | 0.392 | <i>J_y</i> | <i>W_y</i> | |
|  | 72506 | <i>J_x</i> | <i>W_x</i> | FERMAVETRO PIANO DA 47.5 MM (PAG. 4.76) |
| | 0.420 | <i>J_y</i> | <i>W_y</i> | |
|  | 72507 | <i>J_x</i> | <i>W_x</i> | FERMAVETRO ARROTONDATO DA 41 MM (PAG. 4.81) |
| | 0.380 | <i>J_y</i> | <i>W_y</i> | |
|  | 72508 | <i>J_x</i> | <i>W_x</i> | FERMAVETRO ARROTONDATO DA 45.5 MM (PAG. 4.81) |
| | 0.416 | <i>J_y</i> | <i>W_y</i> | |
|  | 72509 | <i>J_x</i> | <i>W_x</i> | FERMAVETRO DESIGN DA 34 MM CON CLIP (PAG. 4.83) |
| | 0.382 | <i>J_y</i> | <i>W_y</i> | |
|  | 72512 | <i>J_x</i> | <i>W_x</i> | FERMAVETRO DESIGN DA 28 MM CON CLIP (PAG. 4.83) |
| | 0.348 | <i>J_y</i> | <i>W_y</i> | |
|  | 72519 | <i>J_x</i> | <i>W_x</i> | FERMAVETRO DESIGN DA 20 MM CON CLIP (PAG. 4.83) |
| | 0.303 | <i>J_y</i> | <i>W_y</i> | |

|  SAGOMA | ARTICOLO | INERZIA | MODULO | DESCRIZIONE |
|---|--------------------|-----------------------|-----------------------|---|
| | PESO (Kg/m) | cm⁴ | cm³ | |
|  | 72527 | <i>J_x</i> | <i>W_x</i> | FERMAVETRO TUBOLARE DA 35.5 MM (PAG. 4.79) |
| | 0.435 | <i>J_y</i> | <i>W_y</i> | |
|  | 72528 | <i>J_x</i> | <i>W_x</i> | FERMAVETRO TUBOLARE DA 33 MM (PAG. 4.79) |
| | 0.425 | <i>J_y</i> | <i>W_y</i> | |
|  | 72529 | <i>J_x</i> | <i>W_x</i> | FERMAVETRO TUBOLARE DA 30.5 MM (PAG. 4.79) |
| | 0.415 | <i>J_y</i> | <i>W_y</i> | |
|  | 72530 | <i>J_x</i> | <i>W_x</i> | FERMAVETRO TUBOLARE DA 25.5 MM (PAG. 4.79) |
| | 0.395 | <i>J_y</i> | <i>W_y</i> | |



Profilati Scala 1:1 

TELAIO A MURO

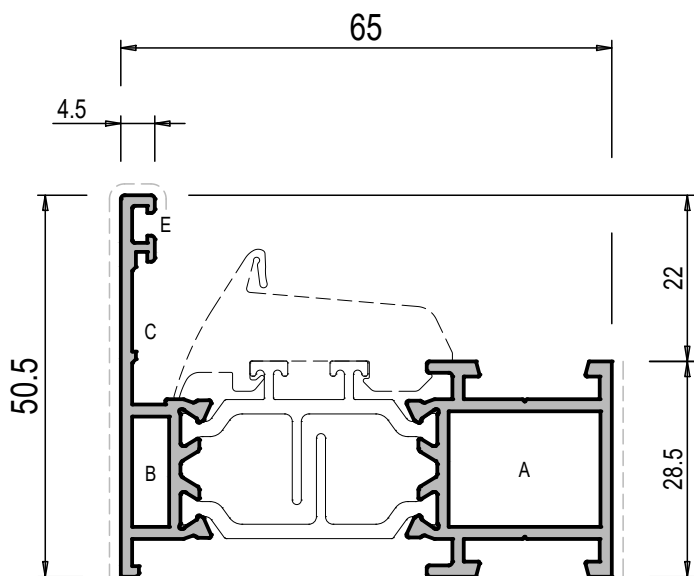

665001

| TELAIO FISSO "L" | | | | | Jx | 4.6 |
|------------------|-------|-------|-------|-------|------|-----|
| PESO | g/m | 1184 | Jy | | 17.1 | |
| S. VISTA | mm | 83.5 | Wx | | 1.4 | |
| | | | Wy | | 4.7 | |
| A | TS078 | TS077 | GA101 | TI001 | | |
| B | TS079 | | GA036 | TI003 | | |
| C | G501N | | | | | |
| E | G112 | | | | | |

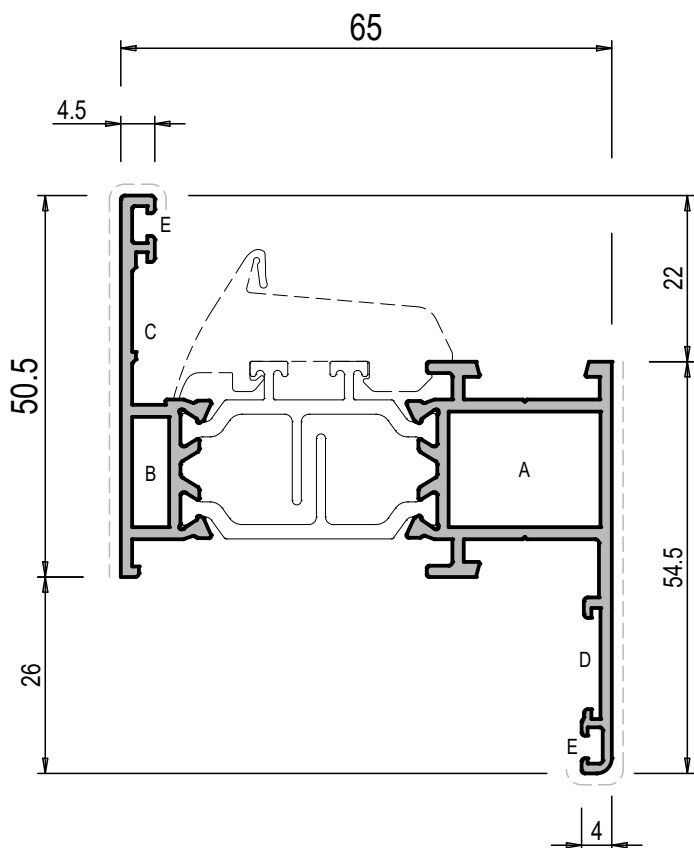

665000

| TELAIO FISSO "Z" | | | | | Jx | 7.7 |
|------------------|-------|-------|-------|-------|------|-----|
| PESO | g/m | 1311 | Jy | | 20.9 | |
| S. VISTA | mm | 113.5 | Wx | | 1.9 | |
| | | | Wy | | 6.2 | |
| A | TS078 | TS077 | GA101 | TI001 | | |
| B | TS079 | | GA036 | TI003 | | |
| C | G501N | | | | | |
| D | G269 | | | | | |
| E | G112 | | | | | |

TELAIO A MURO

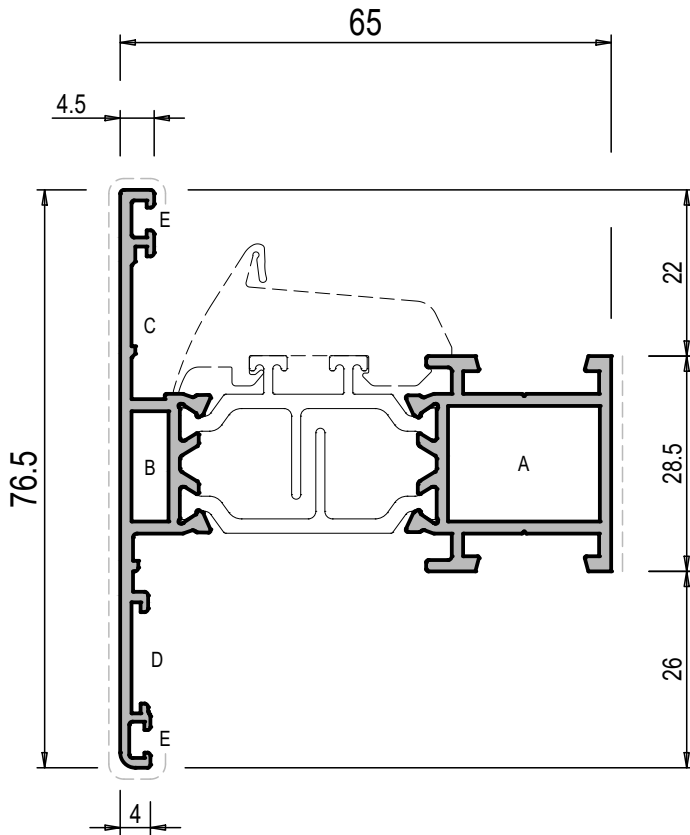

665004

| TELAIO FISSO "T" | | | | Jx cm ⁴ | 7.7 |
|------------------|-------|-------|-------|-----------------------|-----|
| PESO g/m | 1320 | | | | |
| S. VISTA mm | 116 | | | Wx cm ³ | 1.9 |
| | | | | Wy cm ³ | 5.0 |
| A | TS078 | TS077 | GA101 | TI001 | |
| B | TS079 | | | TI003 | |
| C | G501N | | | | |
| D | G269 | | | | |
| E | G112 | | | | |

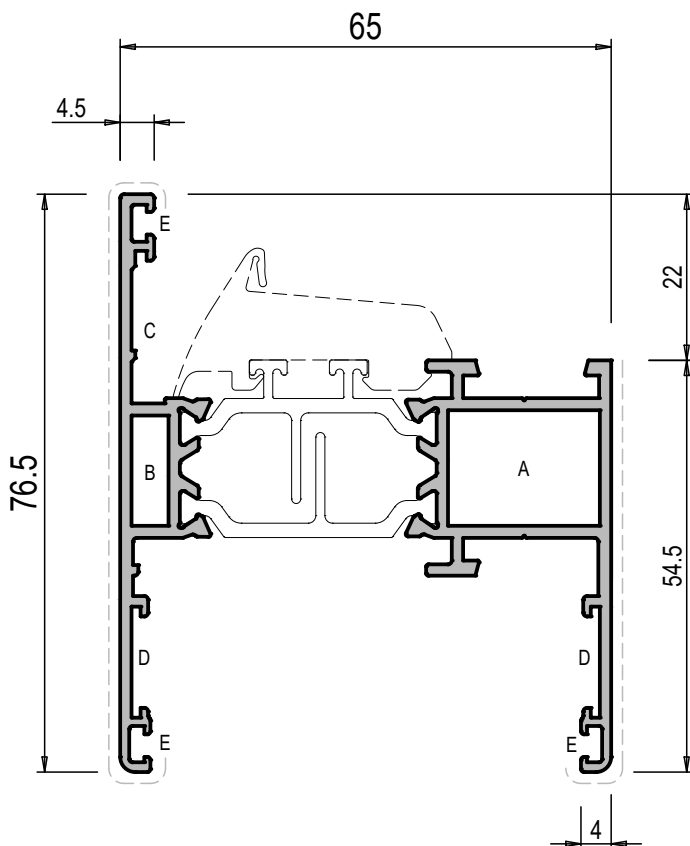

665005

| TELAIO FISSO "H" | | | | Jx cm ⁴ | 10.4 |
|------------------|-------|-------|-------|-----------------------|------|
| PESO g/m | 1447 | | | | |
| S. VISTA mm | 147 | | | Wx cm ³ | 2.7 |
| | | | | Wy cm ³ | 6.6 |
| A | TS078 | TS077 | GA101 | TI001 | |
| B | TS079 | | | TI003 | |
| C | G501N | | | | |
| D | G269 | | | | |
| E | G112 | | | | |

Profilati Scala 1:1



TELAIO A MURO

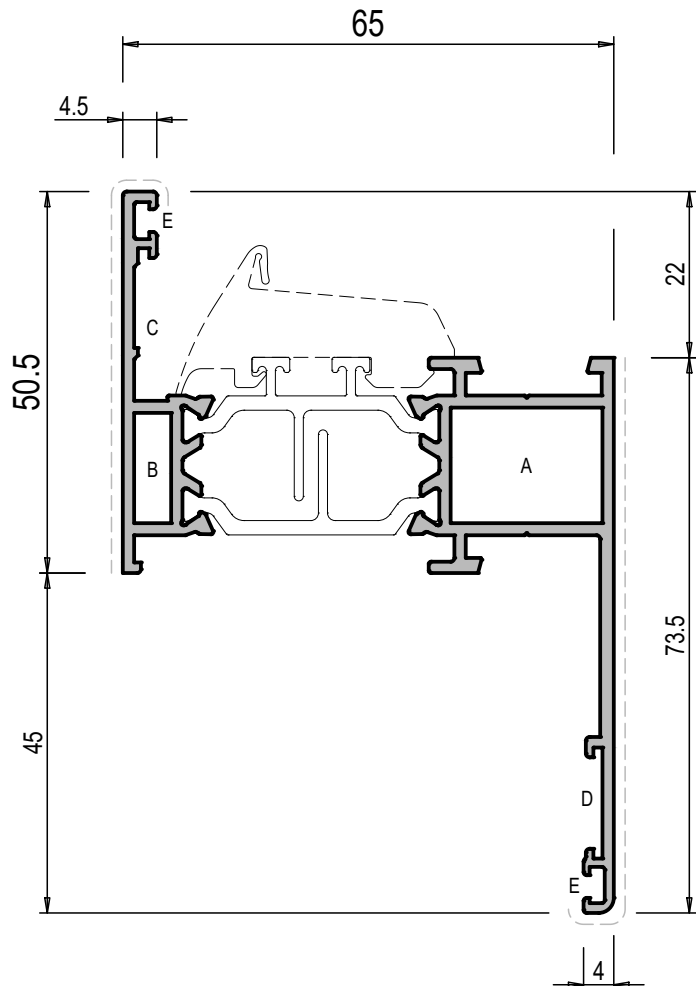

665067

| TELAIO FISSO "L" ALETTA DA 45 | | | Jx | 13.7 |
|-------------------------------|-------|--|----|------|
| PESO | 1406 | | Jy | 23.5 |
| S. VISTA | 132.5 | | Wx | 2.4 |
| g/m | | | Wy | 7.1 |
| mm | | | | |

| | | | | | | |
|---|--|-------|--|-------|-------|-------|
| A | | TS078 | | TS077 | GA101 | TI001 |
| B | | TS079 | | | | TI003 |
| C | | G501N | | | | |
| D | | G269 | | | | |
| E | | G112 | | | | |

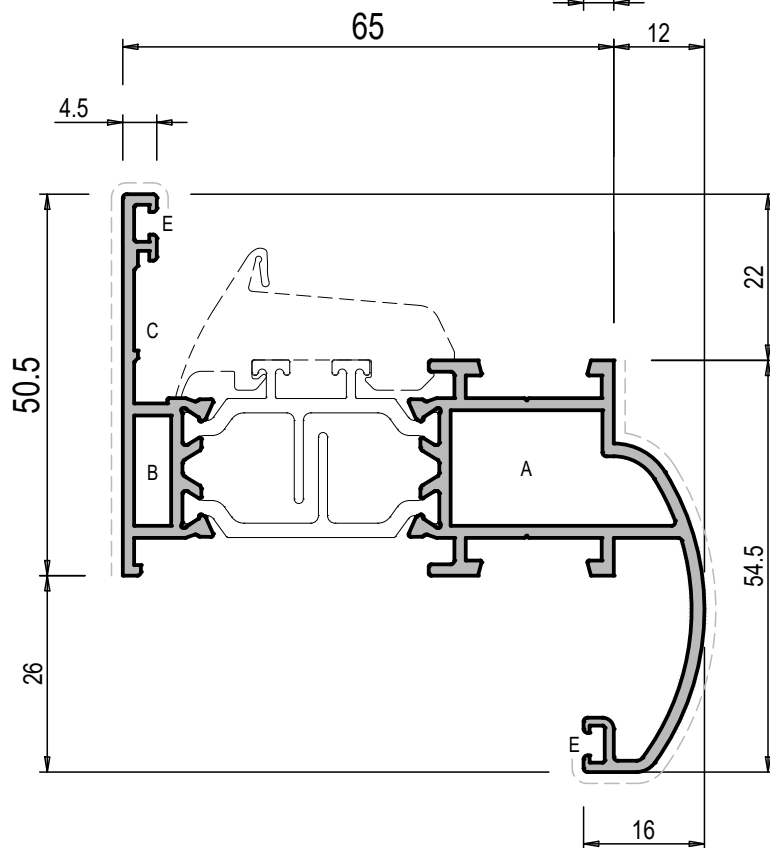

665136

| TELAIO FISSO "Z" ANTARES | | | Jx | 9.8 |
|--------------------------|------|--|----|------|
| PESO | 1464 | | Jy | 28.7 |
| S. VISTA | 128 | | Wx | 2.8 |
| g/m | | | Wy | 7 |
| mm | | | | |

| | | | | | | |
|---|--|-------|--|-------|-------|-------|
| A | | TS078 | | TS077 | GA101 | TI001 |
| B | | TS079 | | | GA036 | TI003 |
| C | | G501N | | | | |
| D | | G269 | | | | |
| E | | G112 | | | | |

TELAIO A MURO

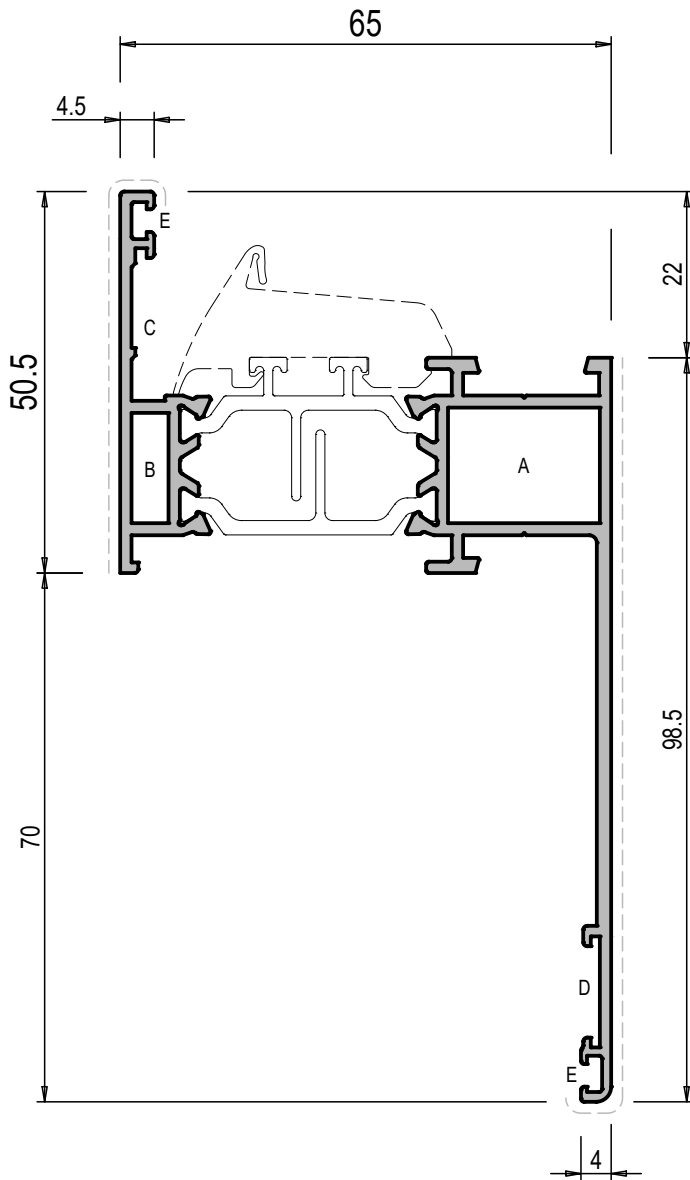

665068

| TELAIO FISSO "L" ALETTA DA 70 | | | Jx | 29.1 |
|-------------------------------|-------|----|-----|------|
| PESO | 1542 | | Jy | 26.6 |
| S. VISTA | 157.5 | Wx | 3.8 | |
| | | Wy | 7.6 | |

| | | | | | | |
|---|--|-------|--|-------|-------|-------|
| A | | TS078 | | TS077 | GA101 | T1001 |
| B | | TS079 | | | | T1003 |
| C | | G501N | | | | |
| D | | G269 | | | | |
| E | | G112 | | | | |

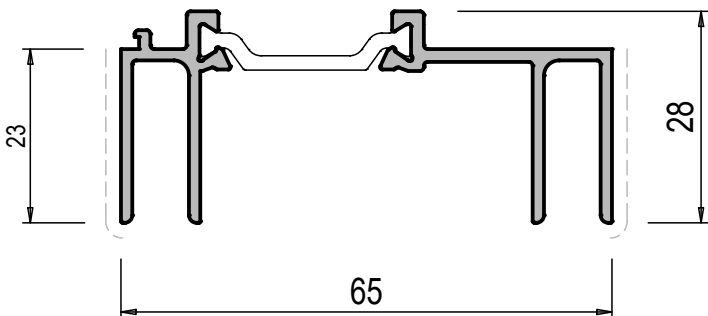

665098

| PROFILATO NASTRI | | | Jx | |
|------------------|-----|----|----|--|
| PESO | 722 | | Jy | |
| S. VISTA | 46 | Wx | | |
| | | Wy | | |

| | | | | | | |
|--|--|--|--|--|--|--|
| | | | | | | |
| | | | | | | |
| | | | | | | |
| | | | | | | |

TELAIO A MURO

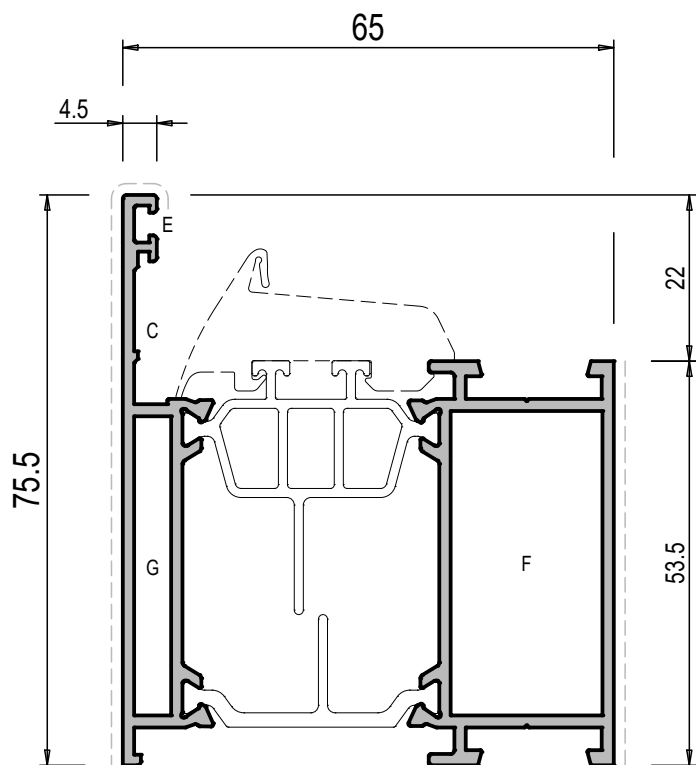

665006

| | | | |
|-----------------------------|------|-----------------------|------|
| TELAIO MAGGIORATO FISSO "L" | | Jx cm ⁴ | 20.0 |
| PESO g/m | 1635 | Jy cm ⁴ | 24.2 |
| S. VISTA mm | 134 | Wx cm ³ | 4.4 |
| | | Wy cm ³ | 6.6 |

| | | | | | |
|---|-------|--|-------|--|-------|
| C | G501N | | | | |
| E | G112 | | | | |
| F | TS080 | | GA101 | | TI001 |
| G | TS081 | | GA036 | | TI003 |

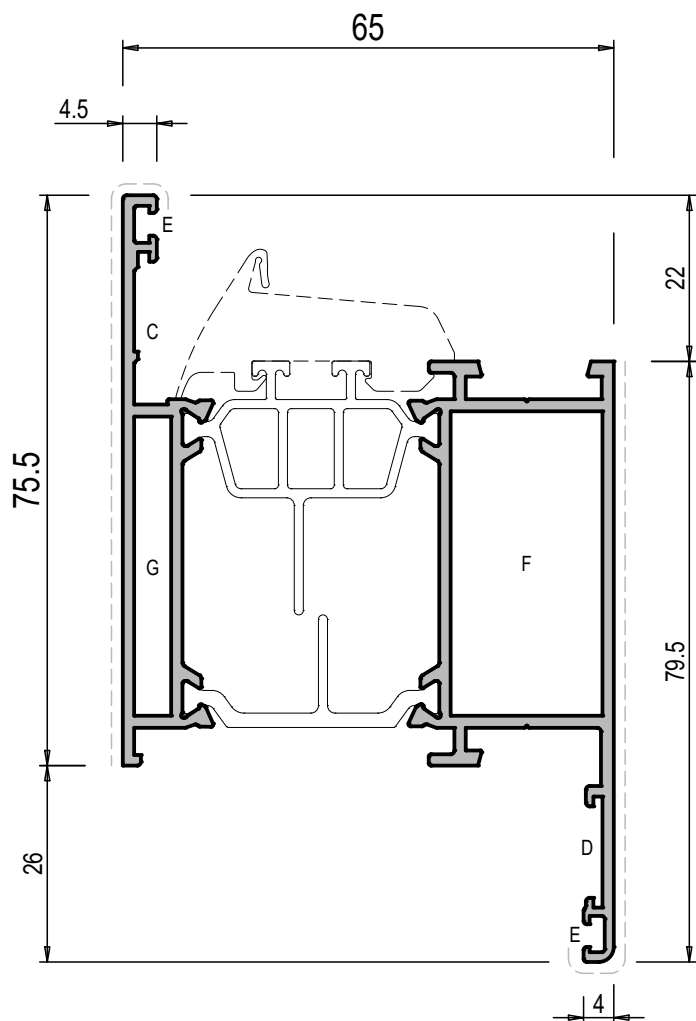

665007

| | | | |
|-----------------------------|------|-----------------------|------|
| TELAIO MAGGIORATO FISSO "Z" | | Jx cm ⁴ | 26.2 |
| PESO g/m | 1735 | Jy cm ⁴ | 28.1 |
| S. VISTA mm | 171 | Wx cm ³ | 4.9 |
| | | Wy cm ³ | 8.2 |

| | | | | |
|---|-------|--|-------|-------|
| C | G501N | | | |
| D | G269 | | | |
| E | G112 | | | |
| F | TS080 | | GA101 | |
| G | TS081 | | GA036 | TI003 |

TELAIO A MURO

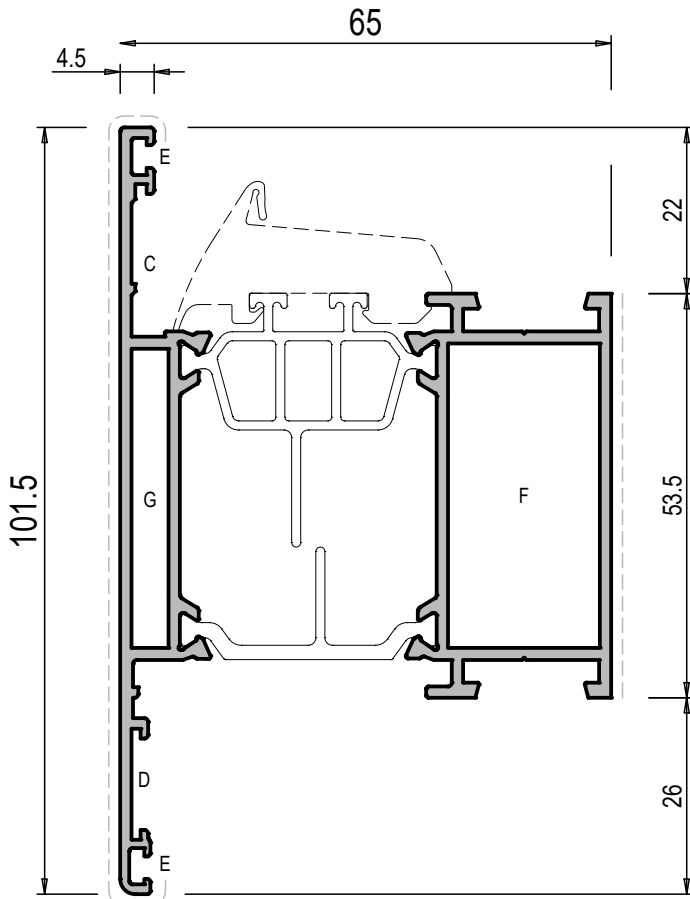

665008

| TELAIO MAGGIORATO FISSO "T" | | | Jx | 26.3 | |
|-----------------------------|-------|----|-------|------|-------|
| PESO | 1770 | | Jy | 26.6 | |
| S. VISTA | 166 | Wx | 4.9 | | |
| | | Wy | 6.9 | | |
| C | G501N | | | | |
| D | G269 | | | | |
| E | G112 | | | | |
| F | TS080 | | GA101 | | T1001 |
| G | TS081 | | | | T1003 |

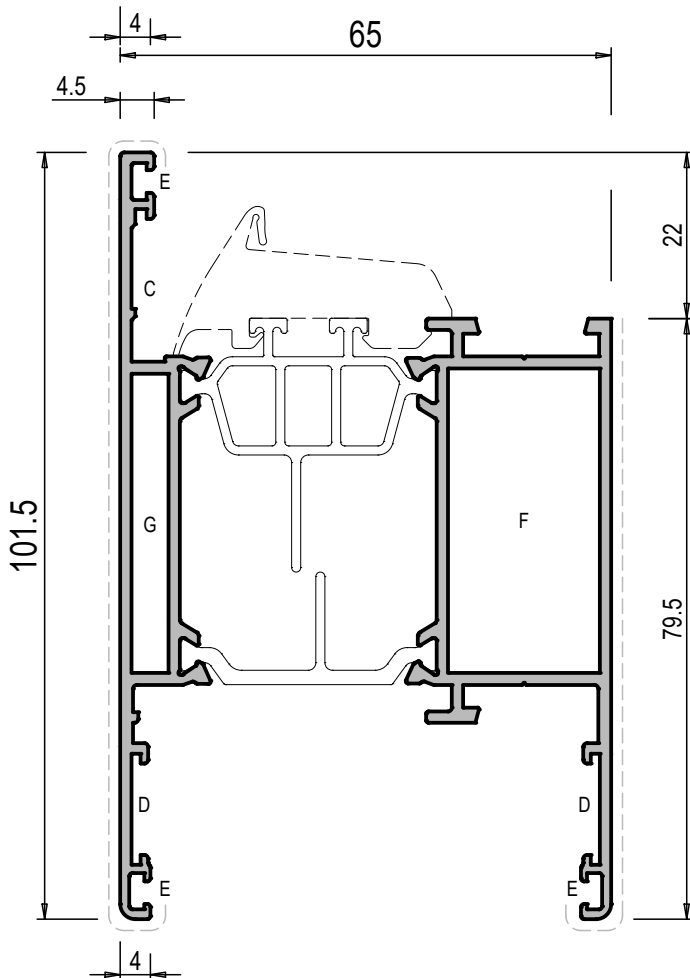

665009

| TELAIO MAGGIORATO FISSO "H" | | | Jx | 31.8 | |
|-----------------------------|-------|----|-------|------|-------|
| PESO | 1870 | | Jy | 31.0 | |
| S. VISTA | 198 | Wx | 5.9 | | |
| | | Wy | 8.6 | | |
| C | G501N | | | | |
| D | G269 | | | | |
| E | G112 | | | | |
| F | TS080 | | GA101 | | T1001 |
| G | TS081 | | | | T1003 |

Profilati Scala 1:1



TELAIO A MURO

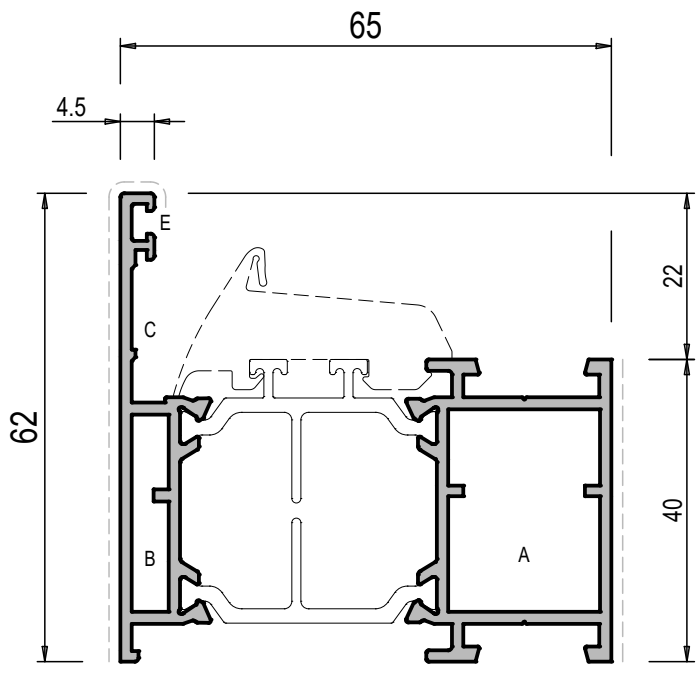

665040

| | | | |
|-----------------------------|------|-----------------------|------|
| TELAIO SEMI-MAGG. FISSO "L" | | Jx cm ⁴ | 9.9 |
| PESO g/m | 1394 | Jy cm ⁴ | 20.8 |
| S. VISTA mm | 107 | Wx cm ³ | 2.5 |
| | | Wy cm ³ | 5.7 |

| | | | | |
|---|-------|-------|-------|-------|
| A | TS078 | TS077 | GA101 | TI001 |
| B | TS079 | | GA036 | TI003 |
| C | G501N | | | |
| E | G112 | | | |

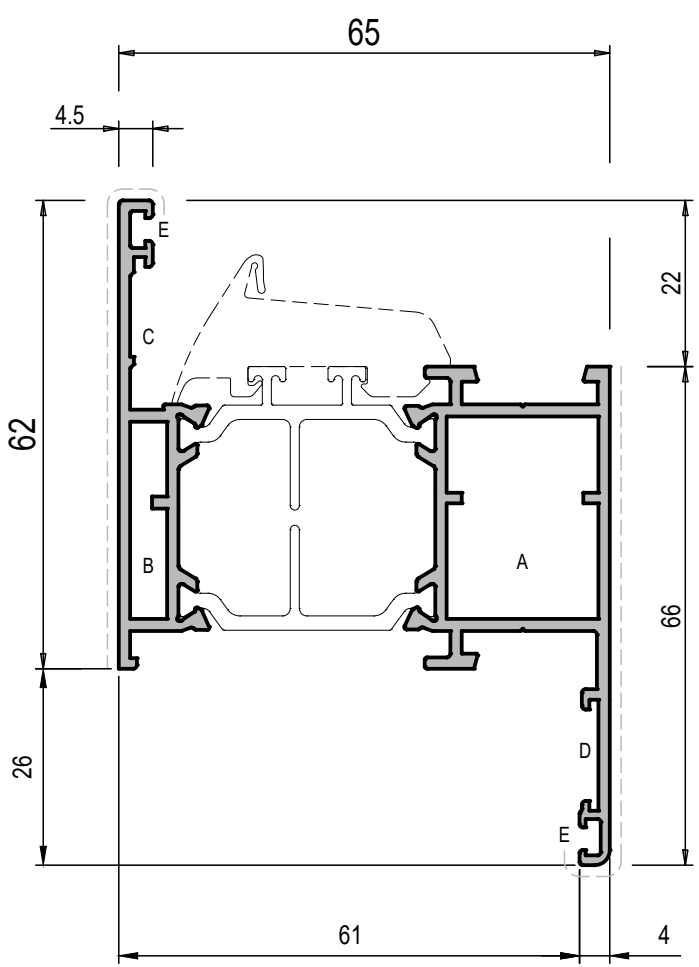

665116

| | | | |
|-----------------------------|-------|-----------------------|------|
| TELAIO SEMI-MAGG. FISSO "Z" | | Jx cm ⁴ | 14 |
| PESO g/m | 1522 | Jy cm ⁴ | 24.5 |
| S. VISTA mm | 136.5 | Wx cm ³ | 2.8 |
| | | Wy cm ³ | 7 |

| | | | | |
|---|-------|-------|-------|-------|
| A | TS078 | TS077 | GA101 | TI001 |
| B | TS079 | | GA036 | TI003 |
| C | G501N | | | |
| D | G269 | | | |
| E | G112 | | | |

TELAIO A MURO

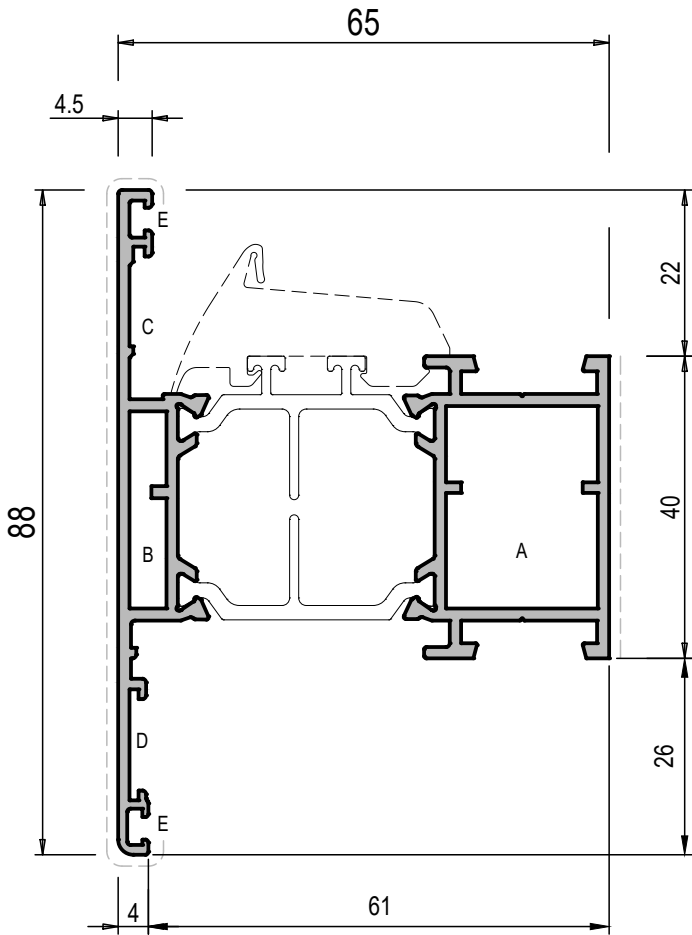

665115

| | | | |
|-----------------------------|-------|-----------------------|------|
| TELAIO SEMI-MAGG. FISSO "T" | | Jx cm ⁴ | 14.7 |
| PESO g/m | 1532 | Jy cm ⁴ | 23.1 |
| S. VISTA mm | 136.5 | Wx cm ³ | 2.8 |
| | | Wy cm ³ | 6.3 |

| | | | | |
|---|-------|-------|-------|-------|
| A | TS078 | TS077 | GA101 | TI001 |
| B | TS079 | | GA036 | TI003 |
| C | G501N | | | |
| D | G269 | | | |
| E | G112 | | | |

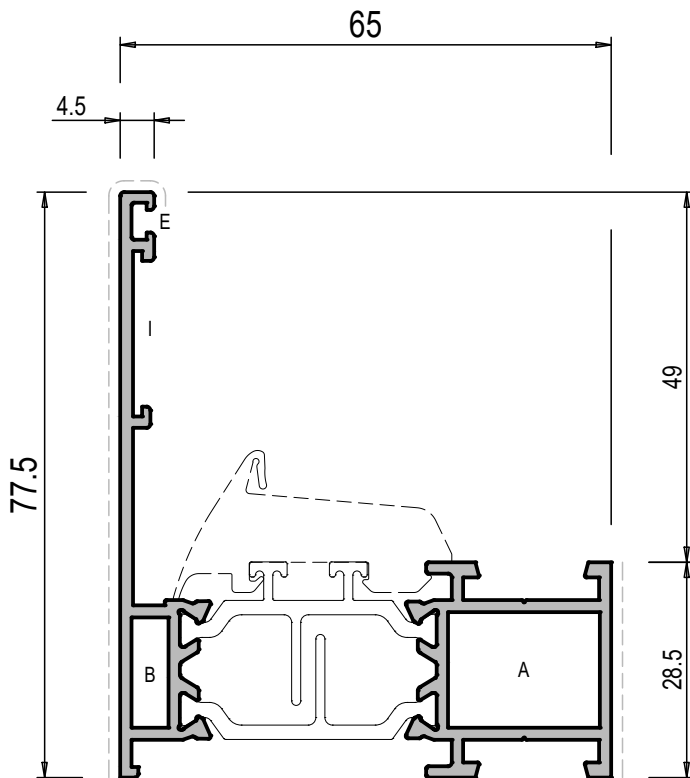

665120

| | | | |
|-----------------------------|------|-----------------------|------|
| TELAIO ANTA A SCOMPARSA "L" | | Jx cm ⁴ | 13.0 |
| PESO g/m | 1332 | Jy cm ⁴ | 19.6 |
| S. VISTA mm | 112 | Wx cm ³ | 2.3 |
| | | Wy cm ³ | 5.0 |

| | | | | |
|---|-------|-------|-------|-------|
| A | TS078 | TS077 | GA101 | TI001 |
| B | TS079 | | GA036 | TI003 |
| I | G267 | | | |
| E | G112 | | | |
| | | | | |

Profilati Scala 1:1



TELAIO A MURO

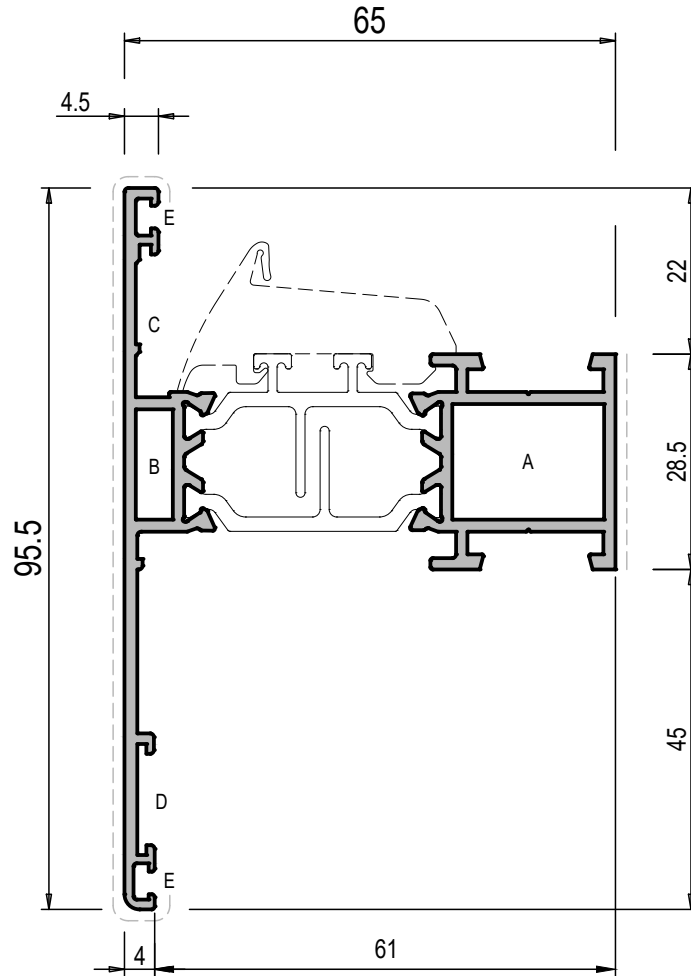

665132

| TELAIO FISSO "T" ALETTA 45 | | | Jx | 14 |
|----------------------------|-------|--|-------|-------|
| PESO | 1411 | | Jy | 21 |
| S. VISTA | 170 | | Wx | 2.8 |
| | | | Wy | 4.9 |
| C | G501N | | | |
| D | G269 | | | |
| E | G112 | | | |
| F | TS080 | | GA101 | |
| G | TS081 | | | |
| | | | | TI001 |
| | | | | TI003 |

TELAIO A MURO

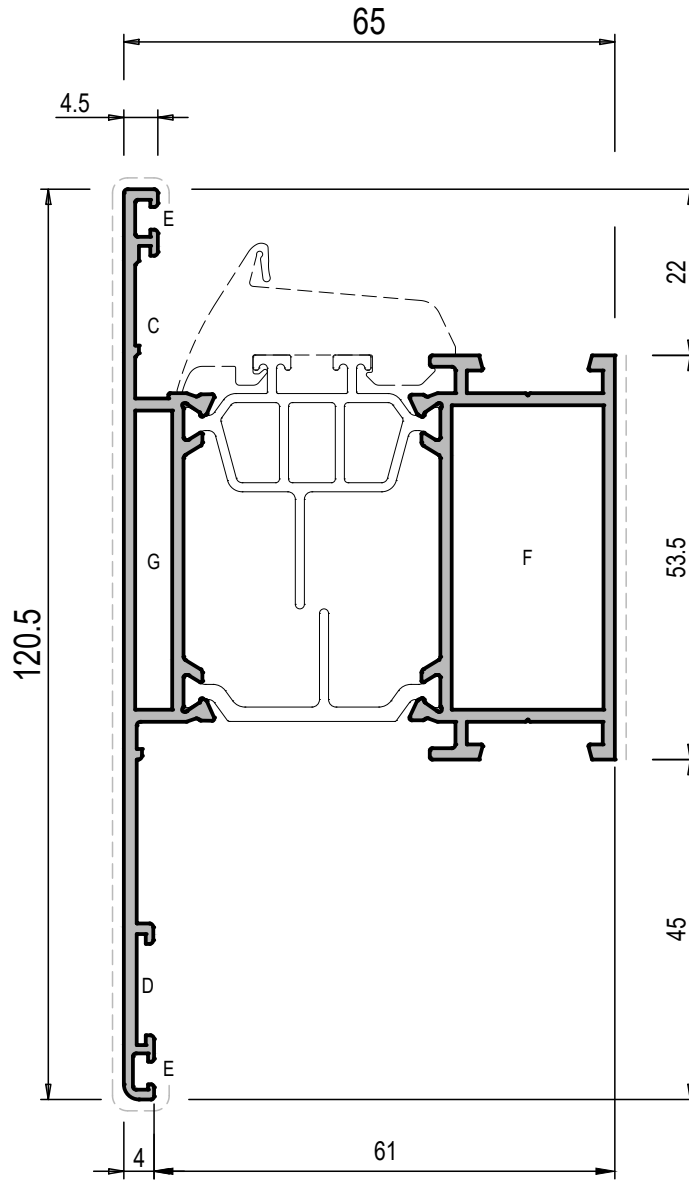

665133

| | | | | |
|-----------------------------|------|--|----|------|
| TELAIO MAGGIORATO FISSO "T" | | | Jx | 36.4 |
| ALETTA 45 | | | Jy | 28.7 |
| PESO | 1868 | | Wx | 7 |
| S. VISTA | 185 | | Wy | 4.9 |
| g/m | | | | |
| mm | | | | |

| | | | | | |
|---|--|-------|-------|-------|--|
| C | | G501N | | | |
| D | | G269 | | | |
| E | | G112 | | | |
| F | | TS080 | GA101 | T1001 | |
| G | | TS081 | | T1003 | |

TELAIO A MURO

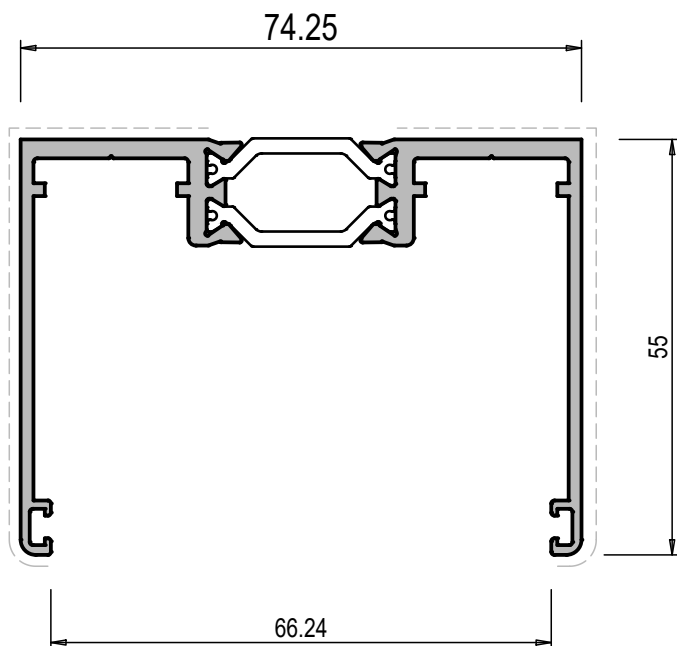

665033

| COMPENSATORE | | Jx cm ⁴ | Jy cm ⁴ | Wx cm ³ | Wy cm ³ |
|----------------|------|-----------------------|-----------------------|-----------------------|-----------------------|
| PESO g/m | 1292 | | | | |
| S. VISTA mm | 164 | | | | |
| | | | | | |
| | | | | | |
| | | | | | |
| | | | | | |
| | | | | | |
| | | | | | |

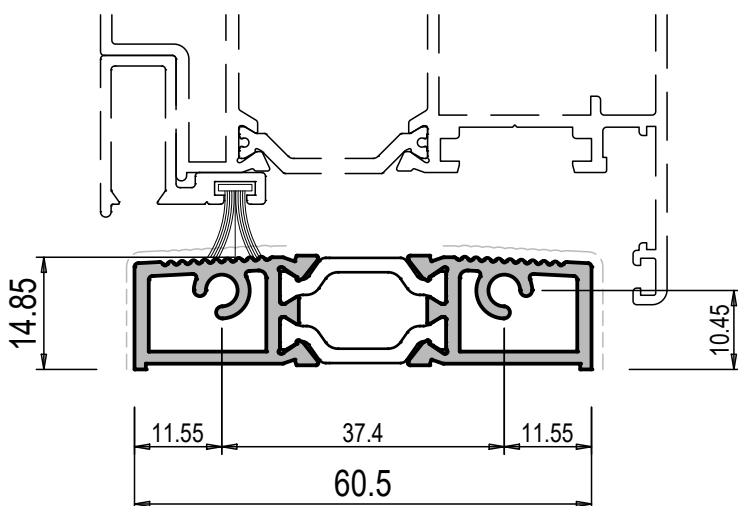

665069

| SOGLIA | | Jx cm ⁴ | Jy cm ⁴ | Wx cm ³ | Wy cm ³ |
|----------------|-----|-----------------------|-----------------------|-----------------------|-----------------------|
| PESO g/m | 932 | | | | |
| S. VISTA mm | 85 | | | | |
| A | | | | | |
| B | | | | | |
| C | | | | | |
| E | | | | | |
| H | | | | | |

SOGLIA RIBASSATA

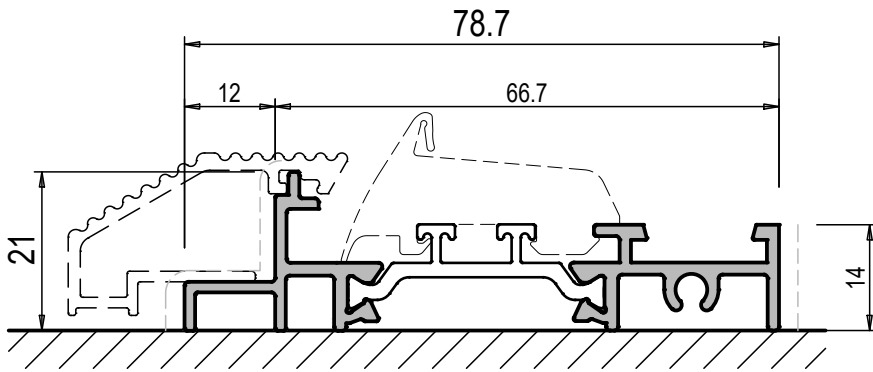

665034

| SOGLIA RIBASSATA | | Jx | cm ⁴ |
|------------------|-----|----|-----------------|
| PESO g/m | 737 | Jy | cm ⁴ |
| S. VISTA mm | 47 | Wx | cm ³ |
| | | Wy | cm ³ |

| | | | |
|--|--|--|--|
| | | | |
| | | | |
| | | | |
| | | | |

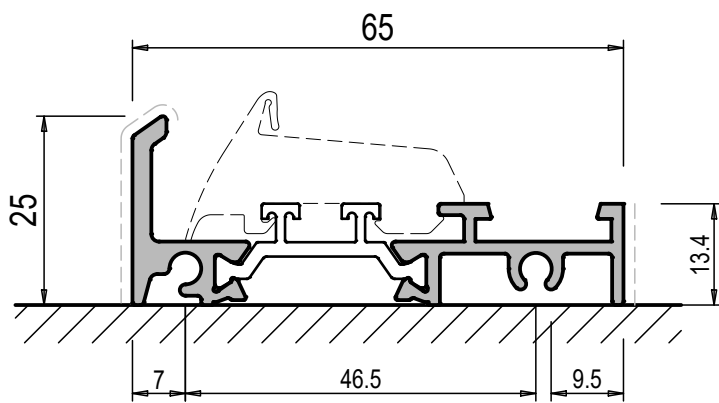

665087

| SOGLIA RIBASSATA | | Jx | cm ⁴ |
|------------------|-----|----|-----------------|
| PESO g/m | 766 | Jy | cm ⁴ |
| S. VISTA mm | 40 | Wx | cm ³ |
| | | Wy | cm ³ |

| | | | |
|--|--|--|--|
| | | | |
| | | | |
| | | | |
| | | | |

Profilati Scala 1:1



ANTE

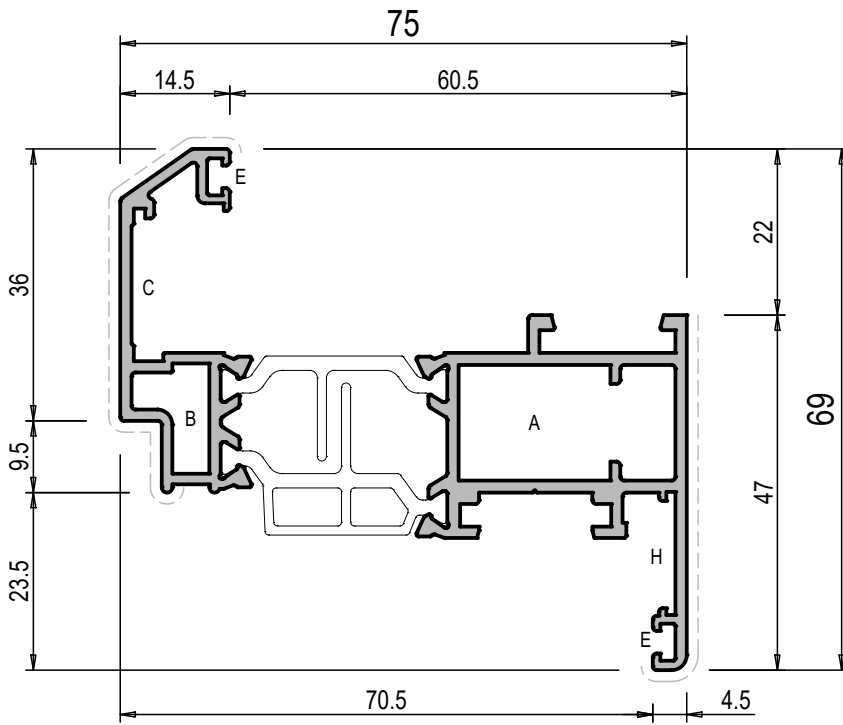

665002

| ANTA "Z" SGUSCIATA | | Jx cm ⁴ | 8.3 |
|--------------------|------|-----------------------|-----|
| PESO g/m | 1466 | | |
| S. VISTA mm | 113 | Wx cm ³ | 2.3 |
| | | Wy cm ³ | 6.9 |

| | | | | |
|---|-------|-------|-------|-------|
| A | TS078 | TS077 | GA101 | TI001 |
| B | TS079 | | GA036 | TI003 |
| C | G501N | | | |
| E | G112 | | | |
| H | G268 | | | |

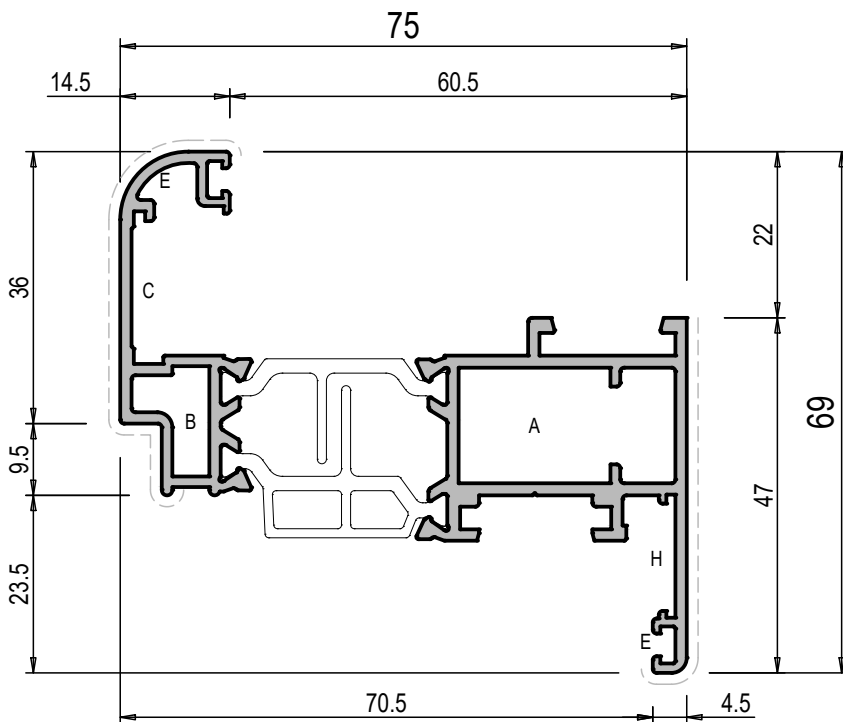

665039

| ANTA "Z" ARROTONDATA | | Jx cm ⁴ | 8.5 |
|----------------------|------|-----------------------|-----|
| PESO g/m | 1470 | | |
| S. VISTA mm | 112 | Wx cm ³ | 2.4 |
| | | Wy cm ³ | 6.9 |

| | | | | |
|---|-------|-------|-------|-------|
| A | TS078 | TS077 | GA101 | TI001 |
| B | TS079 | | GA036 | TI003 |
| C | G501N | | | |
| E | G112 | | | |
| H | G268 | | | |

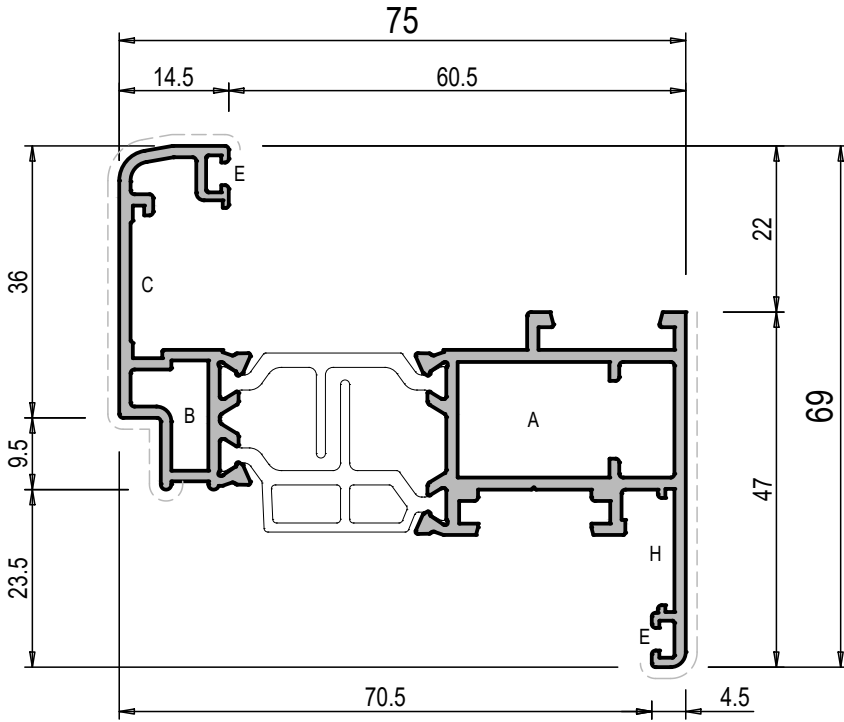

665050

| | | | | | | | | | | | | | | | | | | | | | | | | | | | | | | | | | | | | | | |
|---|------|-------|--|--|-----------------------|-------|-----------------------|-------|-----------------------|-------|-----------------------|-----|-------|--|--|-------|-------|---|--|-------|--|--|--|--|---|--|------|--|--|--|--|---|--|------|--|--|--|--|
| PESO g/m | | 1477 | | <table border="1"> <tr> <td>Jx cm⁴</td> <td>8.7</td> </tr> <tr> <td>Jy cm⁴</td> <td>27.3</td> </tr> <tr> <td>Wx cm³</td> <td>2.4</td> </tr> <tr> <td>Wy cm³</td> <td>6.9</td> </tr> </table> | Jx cm ⁴ | 8.7 | Jy cm ⁴ | 27.3 | Wx cm ³ | 2.4 | Wy cm ³ | 6.9 | | | | | | | | | | | | | | | | | | | | | | | | | | |
| Jx cm ⁴ | 8.7 | | | | | | | | | | | | | | | | | | | | | | | | | | | | | | | | | | | | | |
| Jy cm ⁴ | 27.3 | | | | | | | | | | | | | | | | | | | | | | | | | | | | | | | | | | | | | |
| Wx cm ³ | 2.4 | | | | | | | | | | | | | | | | | | | | | | | | | | | | | | | | | | | | | |
| Wy cm ³ | 6.9 | | | | | | | | | | | | | | | | | | | | | | | | | | | | | | | | | | | | | |
| S. VISTA mm | | 116 | | | | | | | | | | | | | | | | | | | | | | | | | | | | | | | | | | | | |
| <table border="1"> <tr> <td>A</td> <td></td> <td>TS078</td> <td></td> <td>TS077</td> <td>GA101</td> <td>T1001</td> </tr> <tr> <td>B</td> <td></td> <td>TS079</td> <td></td> <td></td> <td>GA036</td> <td>T1003</td> </tr> <tr> <td>C</td> <td></td> <td>G501N</td> <td></td> <td></td> <td></td> <td></td> </tr> <tr> <td>E</td> <td></td> <td>G112</td> <td></td> <td></td> <td></td> <td></td> </tr> <tr> <td>H</td> <td></td> <td>G268</td> <td></td> <td></td> <td></td> <td></td> </tr> </table> | | | | A | | TS078 | | TS077 | GA101 | T1001 | B | | TS079 | | | GA036 | T1003 | C | | G501N | | | | | E | | G112 | | | | | H | | G268 | | | | |
| A | | TS078 | | TS077 | GA101 | T1001 | | | | | | | | | | | | | | | | | | | | | | | | | | | | | | | | |
| B | | TS079 | | | GA036 | T1003 | | | | | | | | | | | | | | | | | | | | | | | | | | | | | | | | |
| C | | G501N | | | | | | | | | | | | | | | | | | | | | | | | | | | | | | | | | | | | |
| E | | G112 | | | | | | | | | | | | | | | | | | | | | | | | | | | | | | | | | | | | |
| H | | G268 | | | | | | | | | | | | | | | | | | | | | | | | | | | | | | | | | | | | |

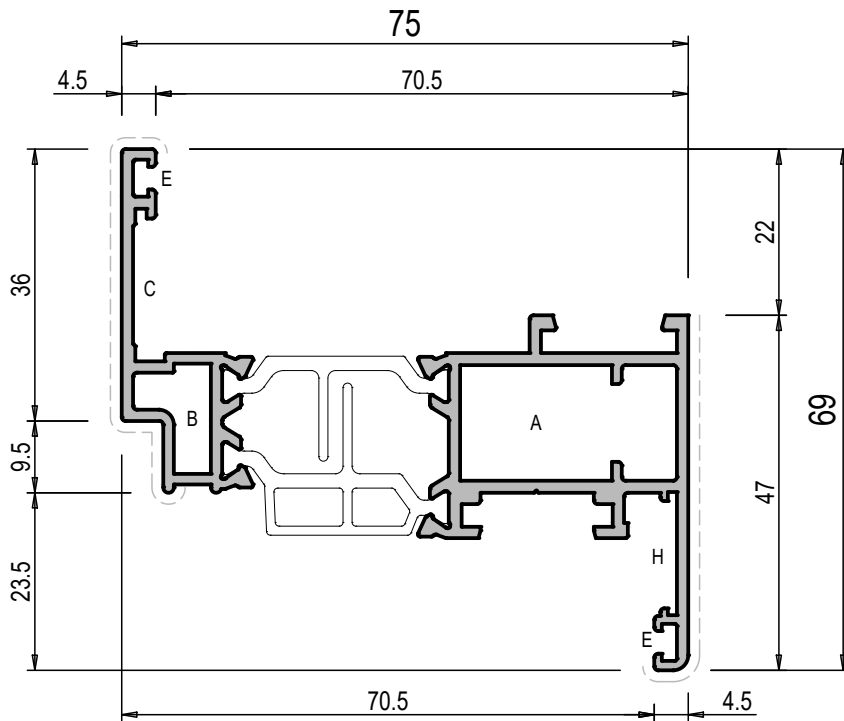

665010

| | | | | | | | | | | | | | | | | | | | | | | | | | | | | | | | | | | | | | | |
|---|------|-------|--|--|-----------------------|-------|-----------------------|-------|-----------------------|-------|-----------------------|-----|-------|--|--|-------|-------|---|--|-------|--|--|--|--|---|--|------|--|--|--|--|---|--|------|--|--|--|--|
| PESO g/m | | 1416 | | <table border="1"> <tr> <td>Jx cm⁴</td> <td>7.0</td> </tr> <tr> <td>Jy cm⁴</td> <td>26.5</td> </tr> <tr> <td>Wx cm³</td> <td>1.9</td> </tr> <tr> <td>Wy cm³</td> <td>6.9</td> </tr> </table> | Jx cm ⁴ | 7.0 | Jy cm ⁴ | 26.5 | Wx cm ³ | 1.9 | Wy cm ³ | 6.9 | | | | | | | | | | | | | | | | | | | | | | | | | | |
| Jx cm ⁴ | 7.0 | | | | | | | | | | | | | | | | | | | | | | | | | | | | | | | | | | | | | |
| Jy cm ⁴ | 26.5 | | | | | | | | | | | | | | | | | | | | | | | | | | | | | | | | | | | | | |
| Wx cm ³ | 1.9 | | | | | | | | | | | | | | | | | | | | | | | | | | | | | | | | | | | | | |
| Wy cm ³ | 6.9 | | | | | | | | | | | | | | | | | | | | | | | | | | | | | | | | | | | | | |
| S. VISTA mm | | 106 | | | | | | | | | | | | | | | | | | | | | | | | | | | | | | | | | | | | |
| <table border="1"> <tr> <td>A</td> <td></td> <td>TS078</td> <td></td> <td>TS077</td> <td>GA101</td> <td>T1001</td> </tr> <tr> <td>B</td> <td></td> <td>TS079</td> <td></td> <td></td> <td>GA036</td> <td>T1003</td> </tr> <tr> <td>C</td> <td></td> <td>G501N</td> <td></td> <td></td> <td></td> <td></td> </tr> <tr> <td>E</td> <td></td> <td>G112</td> <td></td> <td></td> <td></td> <td></td> </tr> <tr> <td>H</td> <td></td> <td>G268</td> <td></td> <td></td> <td></td> <td></td> </tr> </table> | | | | A | | TS078 | | TS077 | GA101 | T1001 | B | | TS079 | | | GA036 | T1003 | C | | G501N | | | | | E | | G112 | | | | | H | | G268 | | | | |
| A | | TS078 | | TS077 | GA101 | T1001 | | | | | | | | | | | | | | | | | | | | | | | | | | | | | | | | |
| B | | TS079 | | | GA036 | T1003 | | | | | | | | | | | | | | | | | | | | | | | | | | | | | | | | |
| C | | G501N | | | | | | | | | | | | | | | | | | | | | | | | | | | | | | | | | | | | |
| E | | G112 | | | | | | | | | | | | | | | | | | | | | | | | | | | | | | | | | | | | |
| H | | G268 | | | | | | | | | | | | | | | | | | | | | | | | | | | | | | | | | | | | |

ANTE

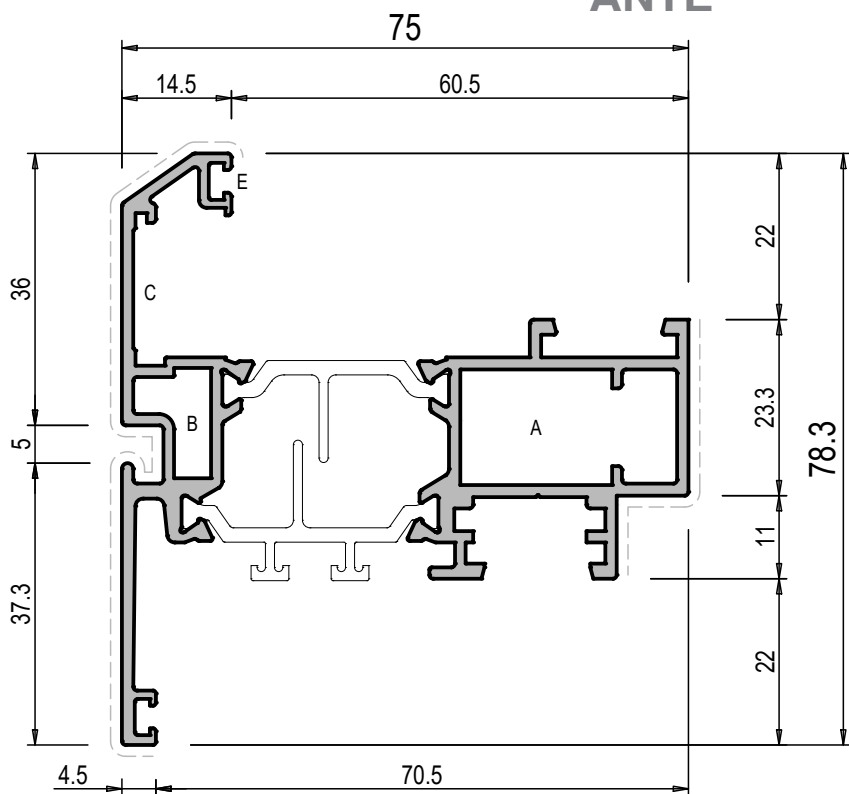

665011

| PESO | | S. VISTA | | Jx | | Jy | | Wx | | Wy | |
|------|-------|----------|----|-----------------|-----------|-----------------|--|-----------------|--|-----------------|--|
| g/m | | mm | | cm ⁴ | | cm ⁴ | | cm ³ | | cm ³ | |
| 1663 | | 150 | | 11.7 | | 28.9 | | 3.0 | | 6.3 | |
| A | TS078 | TS077 | Y | TT067 | CP. TAPPI | | | | | | |
| B | TS079 | | Y1 | TT069 | CP. TAPPI | | | | | | |
| C | G501N | | | | | | | | | | |
| E | G112 | | | | | | | | | | |
| H | G268 | | | | | | | | | | |

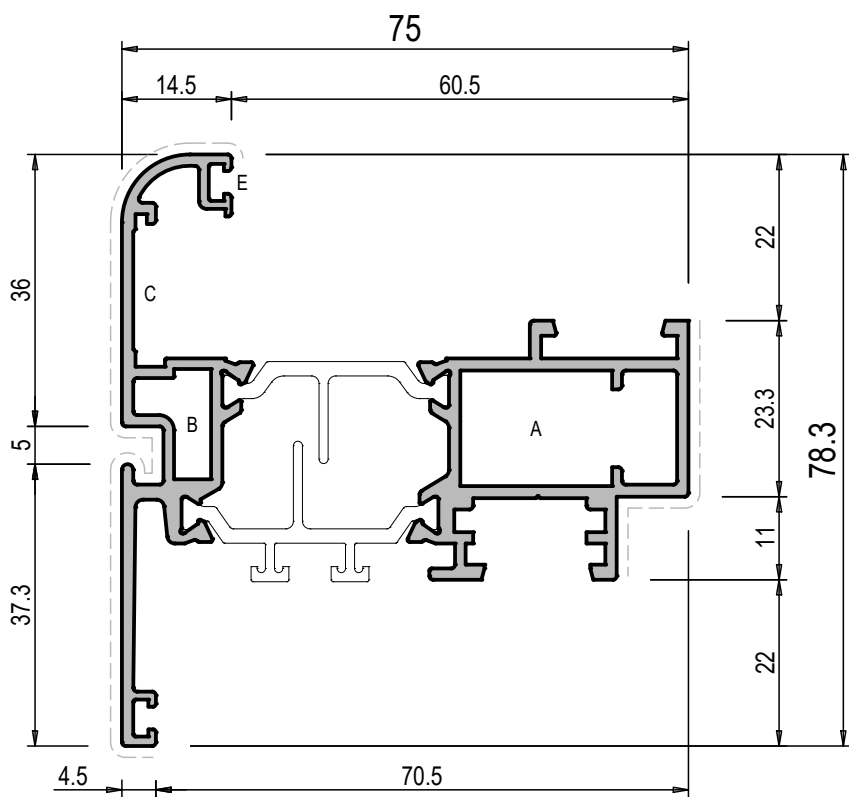

665110

| PESO | | S. VISTA | | Jx | | Jy | | Wx | | Wy | |
|------|-------|----------|----|-----------------|-----------|-----------------|--|-----------------|--|-----------------|--|
| g/m | | mm | | cm ⁴ | | cm ⁴ | | cm ³ | | cm ³ | |
| 1667 | | 150 | | 11.6 | | 28.7 | | 2.9 | | 6.3 | |
| A | TS078 | TS077 | Y | TT067 | CP. TAPPI | | | | | | |
| B | TS079 | | Y1 | TT069 | CP. TAPPI | | | | | | |
| C | G501N | | | | | | | | | | |
| E | G112 | | | | | | | | | | |
| H | G268 | | | | | | | | | | |

ANTE

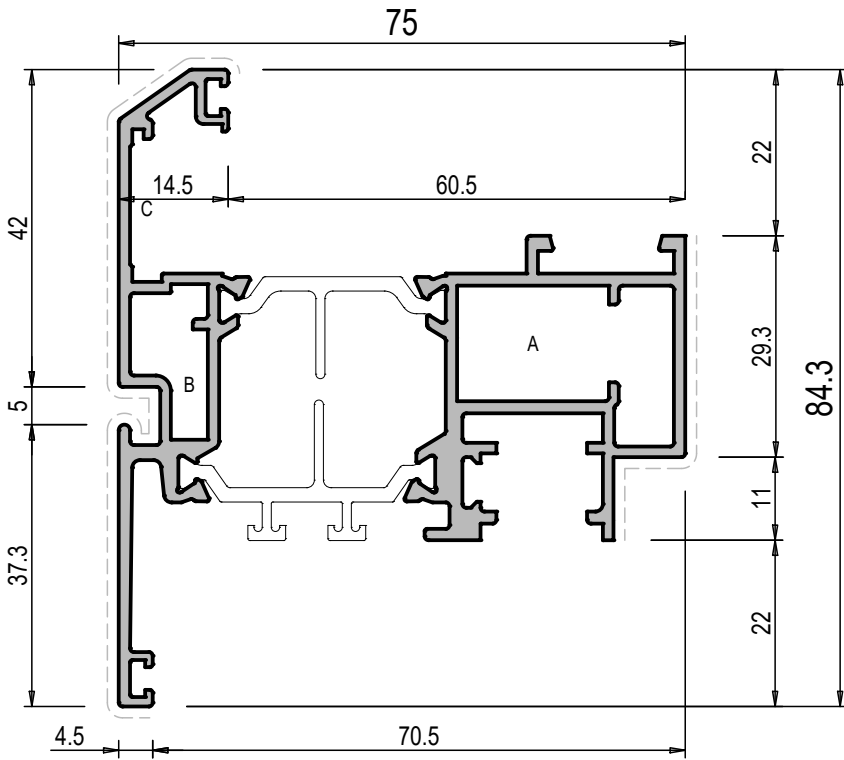

665095

| ANTA "T" SGUSCIATA PISTA 16 | | Jx | 16.1 |
|-----------------------------|-------|----|-----------------|
| PESO | 1728 | Jy | 31.5 |
| S. VISTA | 150 | Wx | 3.5 |
| | | Wy | 7.0 |
| A | TS078 | Y | TT067 CP. TAPPI |
| B | TS079 | Y1 | TT069 CP. TAPPI |
| C | G501N | | |
| E | G112 | | |
| H | G268 | | |

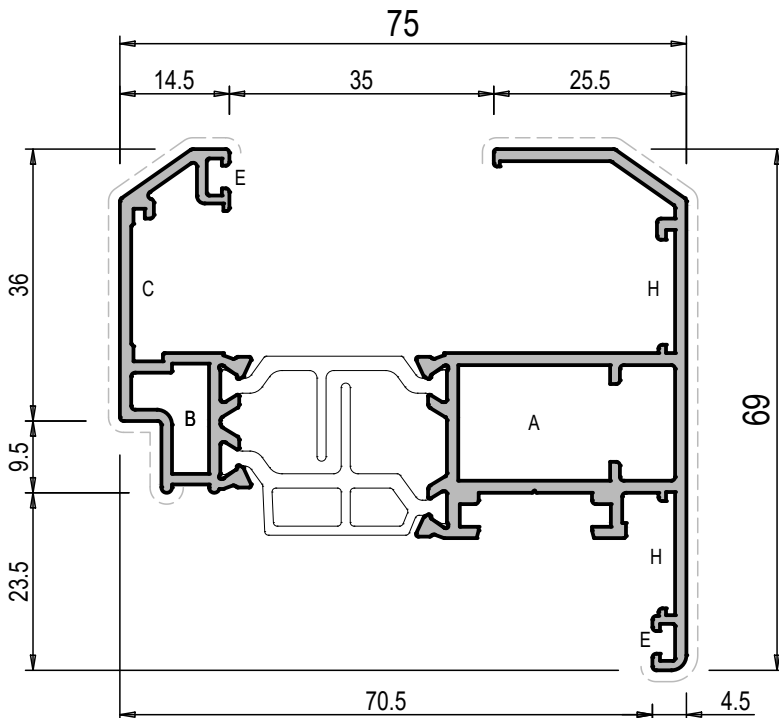

665013

| ANTA VETRO A INFILLO SGUSCIATA | | Jx | 12.1 |
|--------------------------------|-------|-------|-------|
| PESO | 1628 | Jy | 31.1 |
| S. VISTA | 155 | Wx | 3.4 |
| | | Wy | 8.1 |
| A | TS078 | GA101 | TI001 |
| B | TS079 | GA036 | TI003 |
| C | G501N | | |
| E | G112 | | |
| H | G268 | | |

ANTE

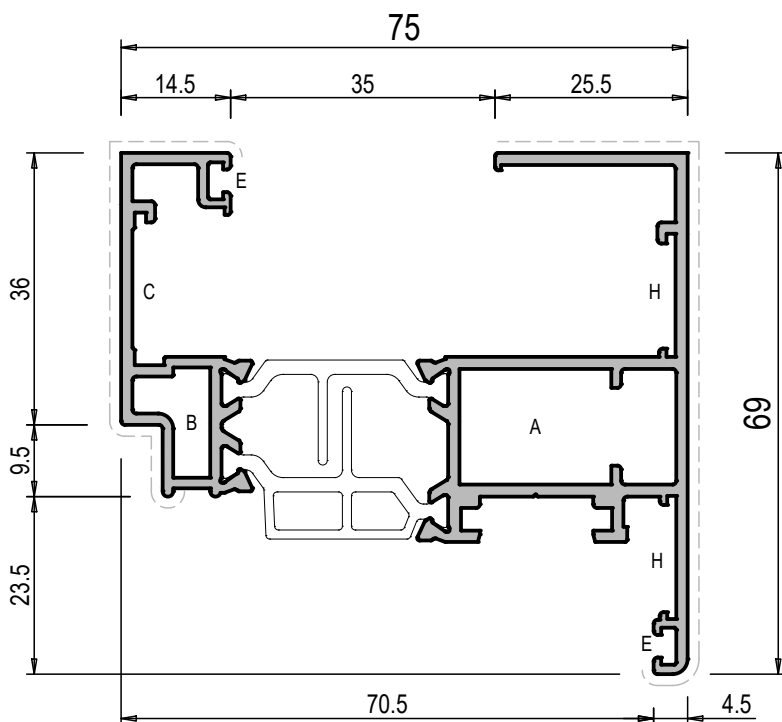

665094

| | | | |
|------------------------------|------|-----------------------|------|
| ANTA VETRO A INFILO PIANA | | Jx cm ⁴ | 13.4 |
| PESO g/m | 1661 | Jy cm ⁴ | 8.5 |
| S. VISTA mm | 138 | Wx cm ³ | 3.5 |
| | | Wy cm ³ | 3.3 |

| | | | | |
|---|-------|-------|-------|-------|
| A | TS078 | TS077 | GA101 | TI001 |
| B | TS079 | | GA036 | TI003 |
| C | G501N | | | |
| E | G112 | | | |
| H | G268 | | | |

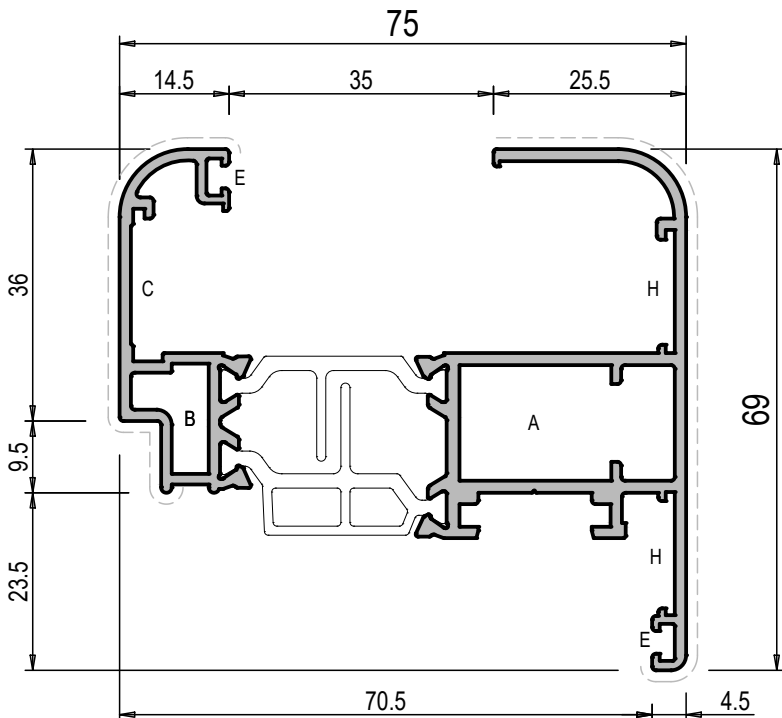

665085

| | | | |
|------------------------------------|------|-----------------------|------|
| ANTA VETRO A INFILO ARROTONDATA | | Jx cm ⁴ | 12.5 |
| PESO g/m | 1642 | Jy cm ⁴ | 31.5 |
| S. VISTA mm | 124 | Wx cm ³ | 3.5 |
| | | Wy cm ³ | 8.2 |

| | | | | |
|---|-------|-------|-------|-------|
| A | TS078 | TS077 | GA101 | TI001 |
| B | TS079 | | GA036 | TI003 |
| C | G501N | | | |
| E | G112 | | | |
| H | G268 | | | |

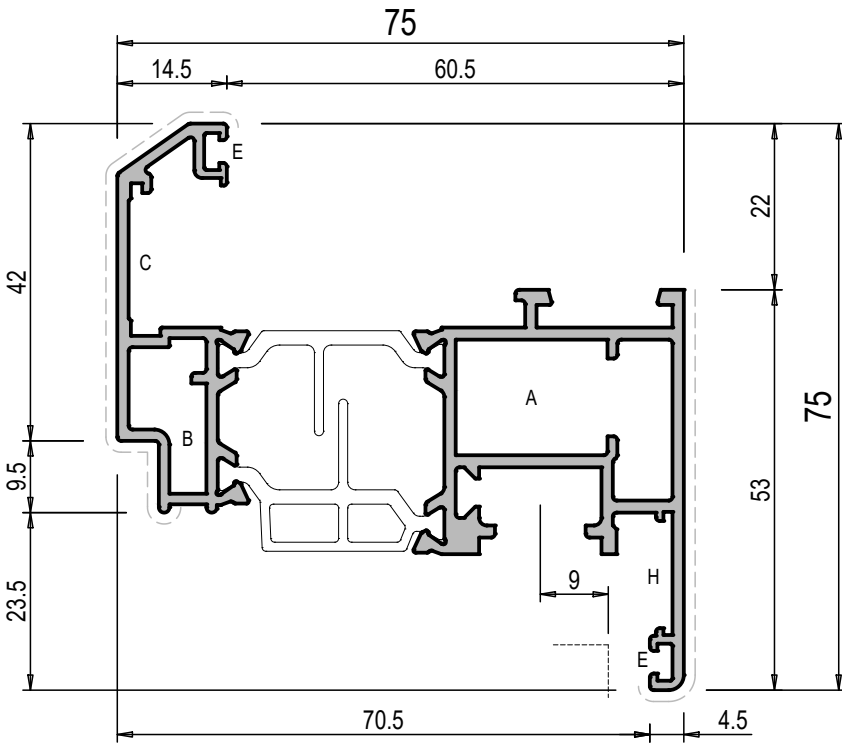

665012

| | | | | | | | | |
|-------------------------|--|-------|--|-------|-----------------|-------|-----------------|------|
| ANTA PISTA 16 SGUSCIATA | | | | Jx | cm ⁴ | 11.5 | | |
| PESO | | | | g/m | 1642 | Jy | cm ⁴ | 29.6 |
| S. VISTA | | | | mm | 124 | Wx | cm ³ | 3.0 |
| | | | | | | Wy | cm ³ | 7.6 |
| A | | TS078 | | TS077 | GA101 | T1001 | | |
| B | | TS079 | | | GA036 | T1003 | | |
| C | | G501N | | | | | | |
| E | | G112 | | | | | | |
| H | | G268 | | | | | | |

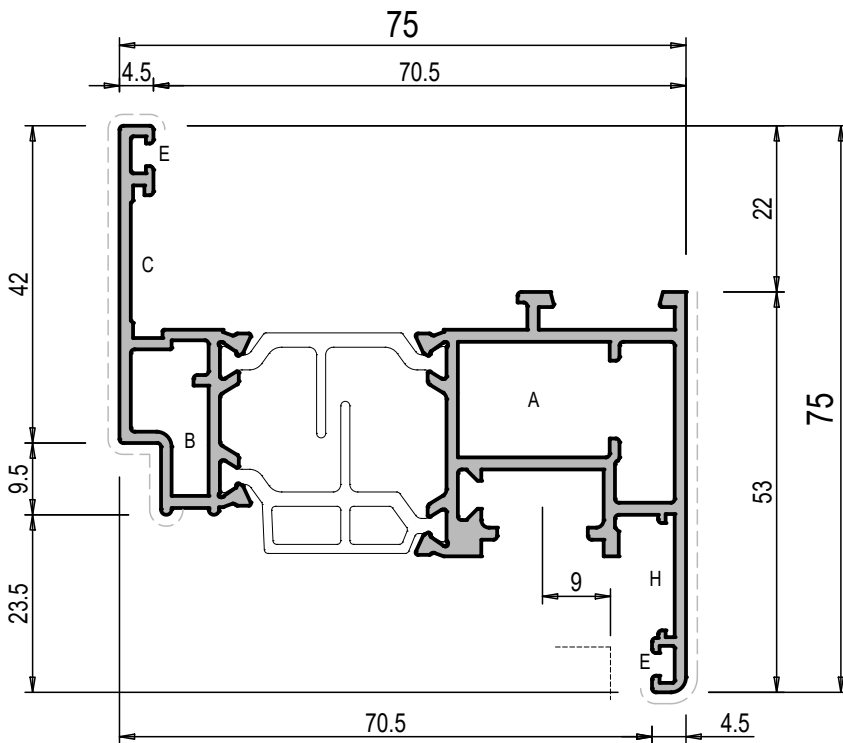

665081

| | | | | | | | | |
|---------------------|--|-------|--|-------|-----------------|-------|-----------------|------|
| ANTA PISTA 16 PIANA | | | | Jx | cm ⁴ | 9.9 | | |
| PESO | | | | g/m | 1593 | Jy | cm ⁴ | 29.3 |
| S. VISTA | | | | mm | 115 | Wx | cm ³ | 2.5 |
| | | | | | | Wy | cm ³ | 7.6 |
| A | | TS078 | | TS077 | GA101 | T1001 | | |
| B | | TS079 | | | GA036 | T1003 | | |
| C | | G501N | | | | | | |
| E | | G112 | | | | | | |
| H | | G268 | | | | | | |

ANTE

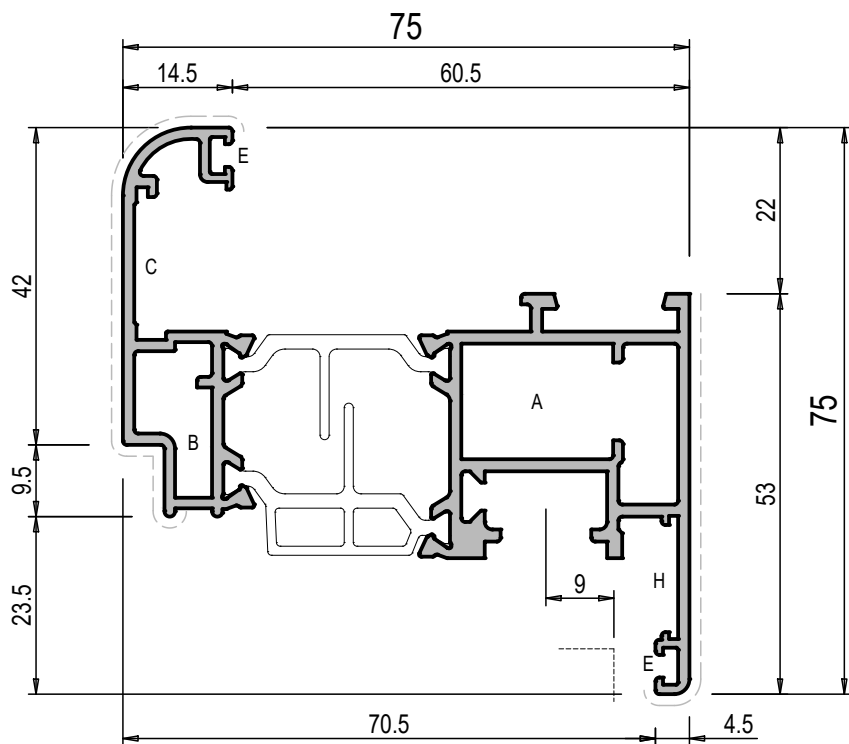

665056

| ANTA PISTA 16 ARROTONDATA | | Jx cm ⁴ | 11.7 |
|---------------------------|-------|-----------------------|-----------------------|
| PESO g/m | 1646 | | Jy cm ⁴ |
| S. VISTA mm | 125.5 | Wx cm ³ | 3.0 |
| | | Wy cm ³ | 7.6 |

| | | | | |
|---|-------|-------|-------|-------|
| A | TS078 | TS077 | GA101 | TI001 |
| B | TS079 | | GA036 | TI003 |
| C | G501N | | | |
| E | G112 | | | |
| H | G268 | | | |

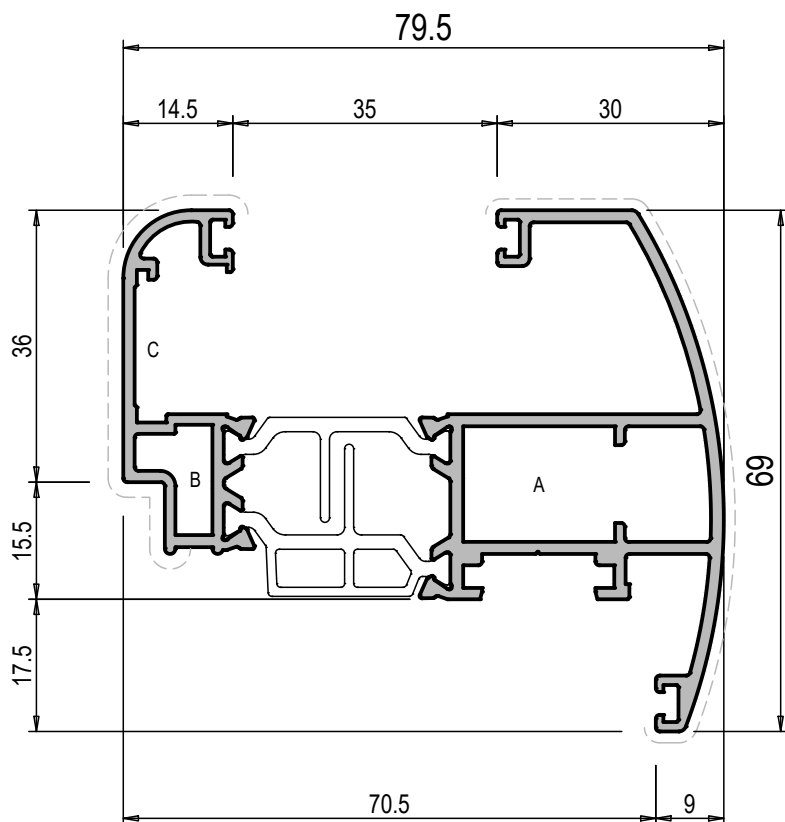

665100

| ANTA VETRO A INFILO ANTARES I.V. 35 | | Jx cm ⁴ | 13.3 |
|--|------|-----------------------|-----------------------|
| PESO g/m | 1718 | | Jy cm ⁴ |
| S. VISTA mm | 157 | Wx cm ³ | 3.5 |
| | | Wy cm ³ | 8.4 |

| | | | | |
|---|-------|-------|-------|--------|
| A | TS078 | TS077 | TI001 | GA083C |
| B | TS079 | | TI003 | GA136 |
| C | G501N | | | |
| E | G112 | | | |

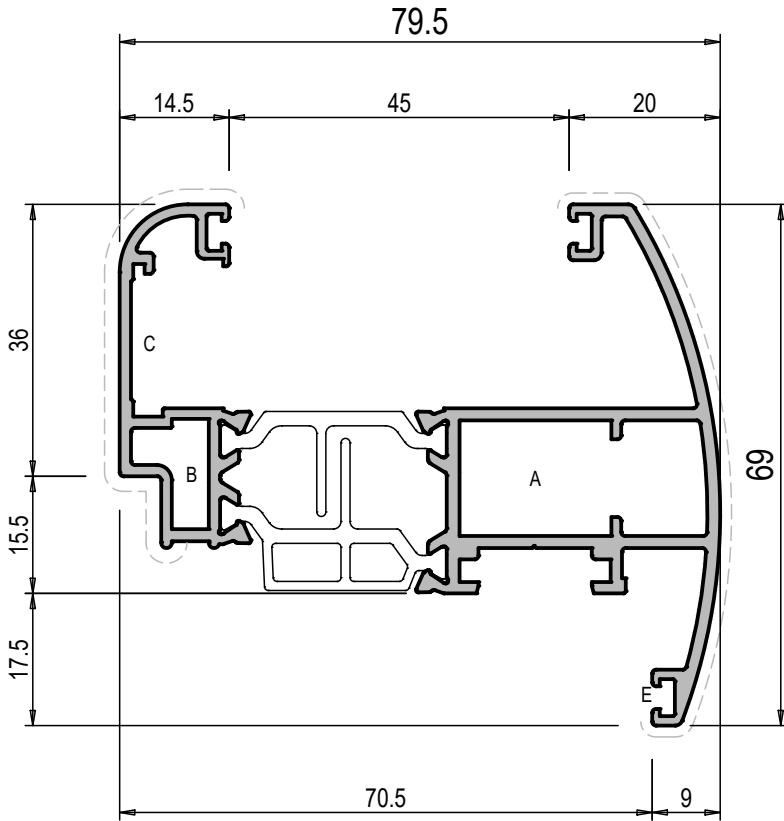

665101

| ANTA VETRO A INFILO ANTARES I.V. 45 | | Jx cm ⁴ | Jy cm ⁴ | Wx cm ³ | Wy cm ³ | | | |
|--|-------|-----------------------|-----------------------|-----------------------|-----------------------|-------|-------|--------|
| PESO g/m | 1675 | | | | | 8.5 | 27.1 | 2.4 |
| S. VISTA mm | 147 | | | | | | | |
| A | TS078 | | | | | TS077 | T1001 | GA083C |
| B | TS079 | | | | | | T1003 | GA136 |
| C | G501N | | | | | | | |
| E | G112 | | | | | | | |

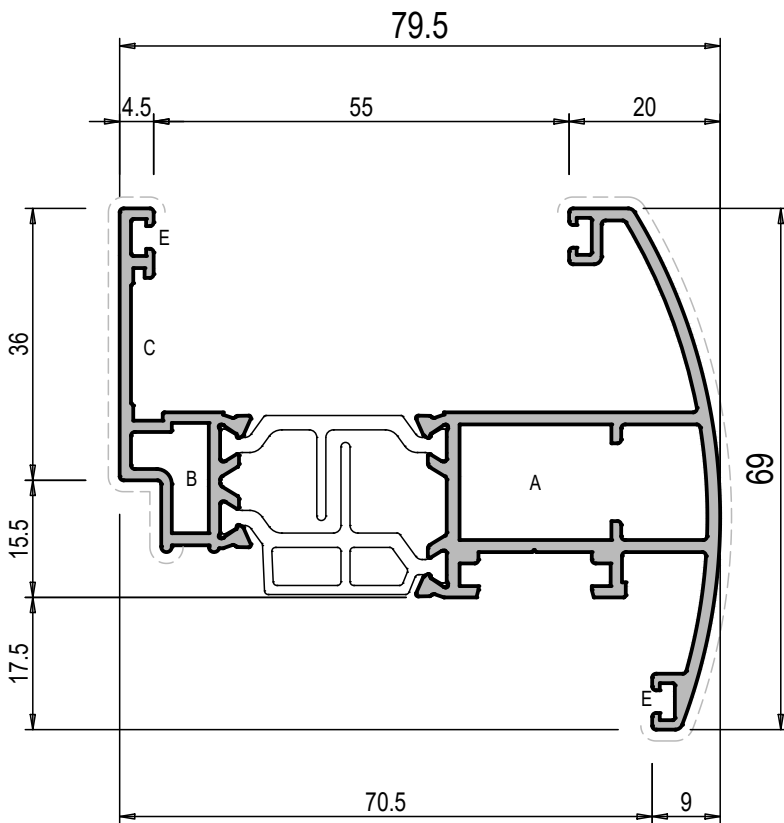

665108

| ANTA VETRO A INFILO ANTARES I.V. 55 | | Jx cm ⁴ | Jy cm ⁴ | Wx cm ³ | Wy cm ³ | | | |
|--|-------|-----------------------|-----------------------|-----------------------|-----------------------|-------|-------|--------|
| PESO g/m | 1621 | | | | | 10.5 | 33.6 | 2.8 |
| S. VISTA mm | 137 | | | | | | | |
| A | TS078 | | | | | TS077 | T1001 | GA083C |
| B | TS079 | | | | | | T1003 | GA136 |
| C | G501N | | | | | | | |
| E | G112 | | | | | | | |

ANTE

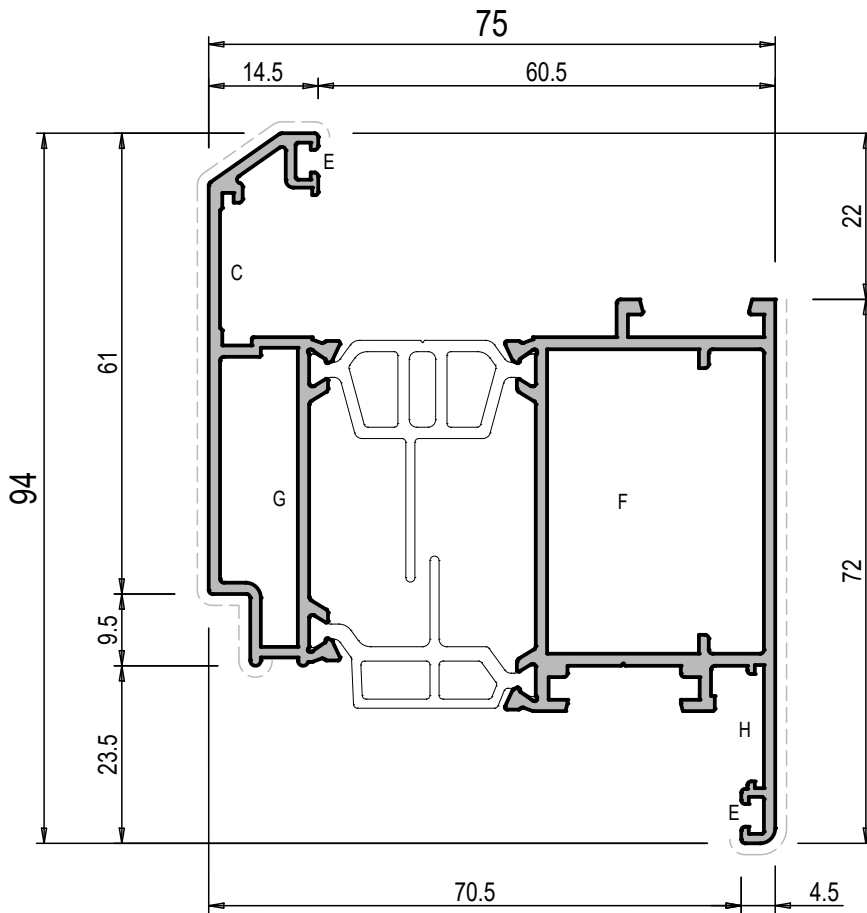

665014

| | | | | | |
|---------------------------|-------|--|-----------------------|------|-------|
| ANTA MAGGIORATA SGUSCIATA | | | Jx cm ⁴ | 28.6 | |
| PESO g/m | 1943 | | Jy cm ⁴ | 35.6 | |
| S. VISTA mm | 162 | | Wx cm ³ | 5.9 | |
| | | | Wy cm ³ | 9.0 | |
| C | G501N | | | | |
| E | G112 | | | | |
| F | TS080 | | GA101 | | TI001 |
| G | TS081 | | GA036 | | TI003 |
| H | G268 | | | | |

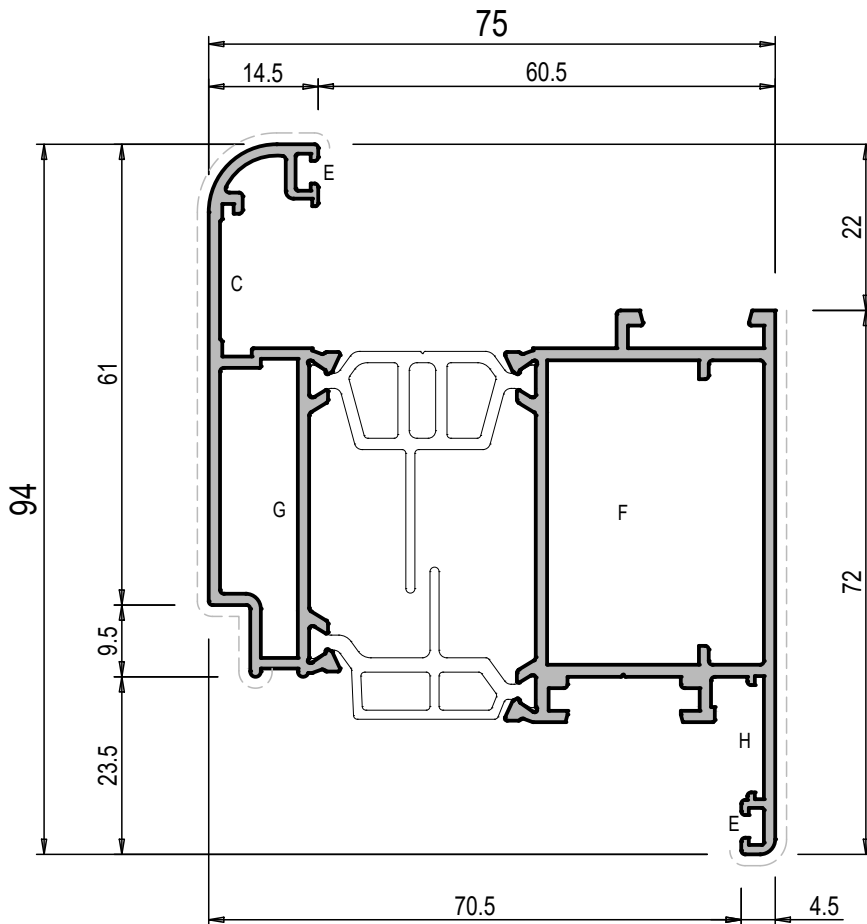

665057

| | | | | | |
|-----------------------|-------|--|-----------------------|------|-------|
| ANTA MAG. ARROTONDATA | | | Jx cm ⁴ | 28.9 | |
| PESO g/m | 1946 | | Jy cm ⁴ | 35.7 | |
| S. VISTA mm | 164.5 | | Wx cm ³ | 5.9 | |
| | | | Wy cm ³ | 9.0 | |
| C | G501N | | | | |
| E | G112 | | | | |
| F | TS080 | | GA101 | | TI001 |
| G | TS081 | | GA036 | | TI003 |
| H | G268 | | | | |

ANTE

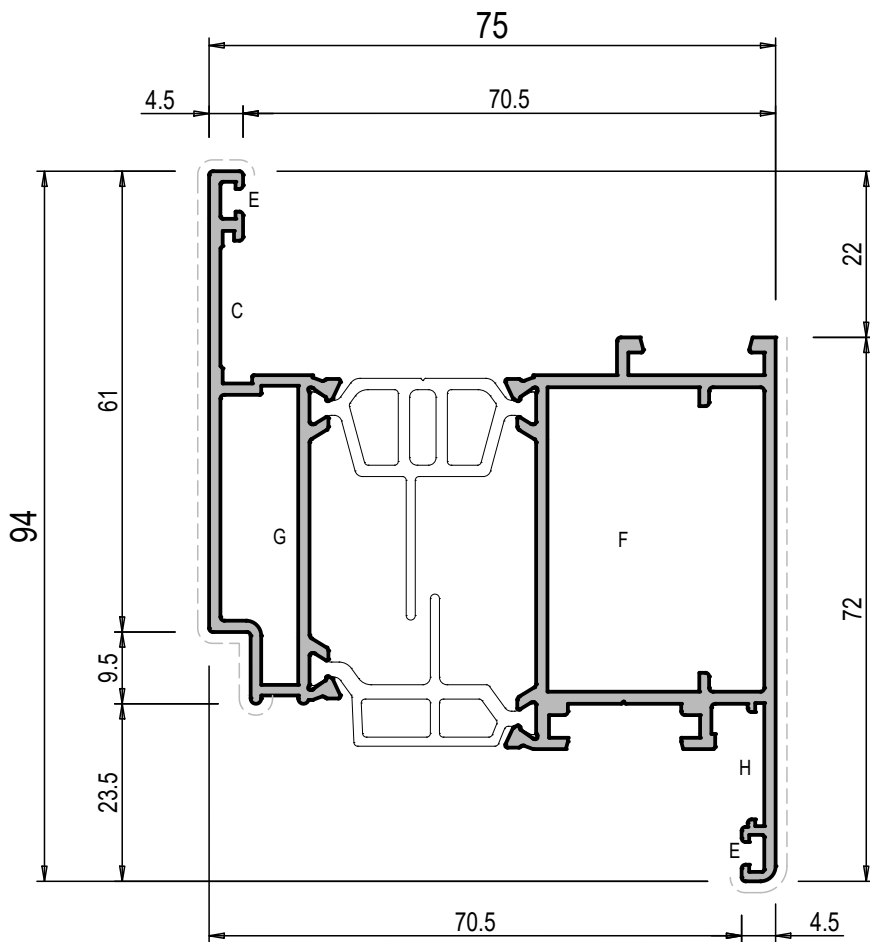

665058

| | | | | | | | |
|---------------------------|--|-------|-----------------|------|-----------------|------|-------|
| ANTA MAGGIORATA "Z" PIANA | | Jx | cm ⁴ | 25.9 | | | |
| PESO | | g/m | 1893 | Jy | cm ⁴ | 35.1 | |
| S. VISTA | | mm | 158 | Wx | cm ³ | 5.2 | |
| | | | | Wy | cm ³ | 9.0 | |
| C | | G501N | | | | | |
| E | | G112 | | | | | |
| F | | TS080 | | | GA101 | | T1001 |
| G | | TS081 | | | GA036 | | T1003 |
| H | | G268 | | | | | |

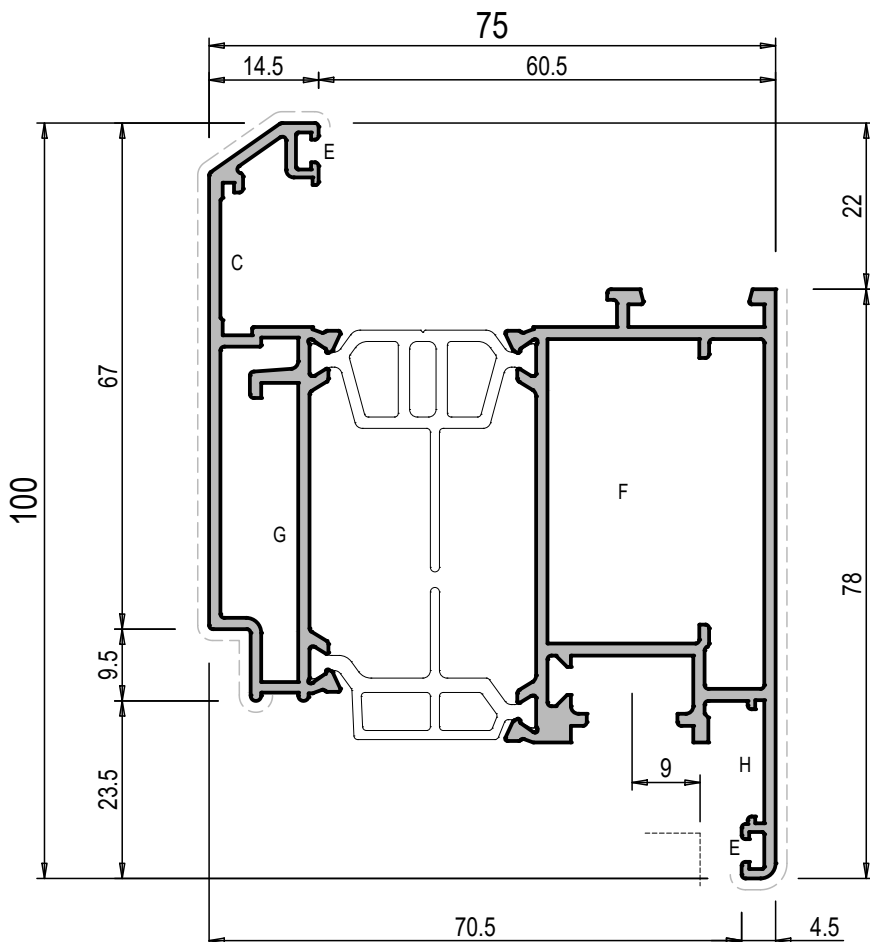

665051

| | | | | | | | |
|-----------------------------|--|-------|-----------------|------|-----------------|------|-------|
| ANTA MAG.PISTA 16 SGUSCIATA | | Jx | cm ⁴ | 36.2 | | | |
| PESO | | g/m | 2163 | Jy | cm ⁴ | 38.9 | |
| S. VISTA | | mm | 175.5 | Wx | cm ³ | 7.0 | |
| | | | | Wy | cm ³ | 9.8 | |
| C | | G501N | | | | | |
| E | | G112 | | | | | |
| F | | TS080 | | | GA101 | | T1001 |
| G | | TS081 | | | GA036 | | T1003 |
| H | | G268 | | | | | |

ANTE

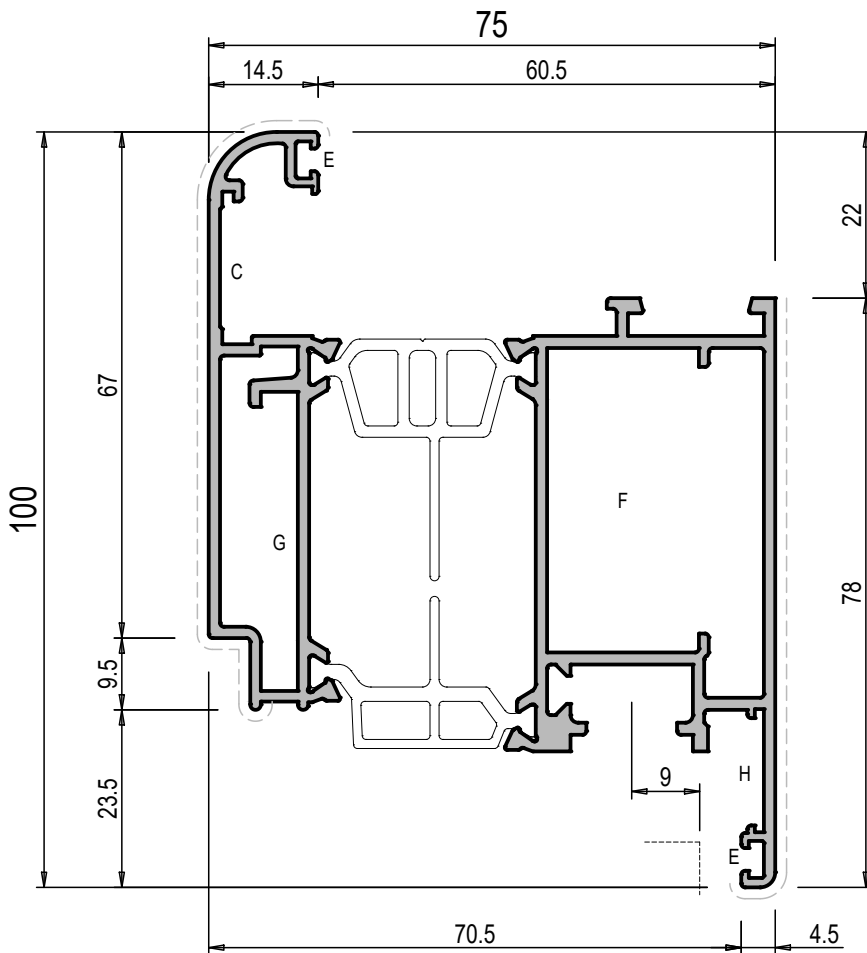

665059

| | | | | | | |
|---------------------------|-------|-------|-----------------|-----------------|------|-------|
| ANTA MAG. PISTA 16 ARROT. | | Jx | cm ⁴ | 36.6 | | |
| PESO | g/m | 2167 | Jy | cm ⁴ | 39.0 | |
| S. VISTA | mm | 176.5 | Wx | cm ³ | 7.1 | |
| | | | Wy | cm ³ | 9.8 | |
| C | G501N | | | | | |
| E | G112 | | | | | |
| F | TS080 | | | GA101 | | TI001 |
| G | TS081 | | | GA036 | | TI003 |
| H | G268 | | | | | |

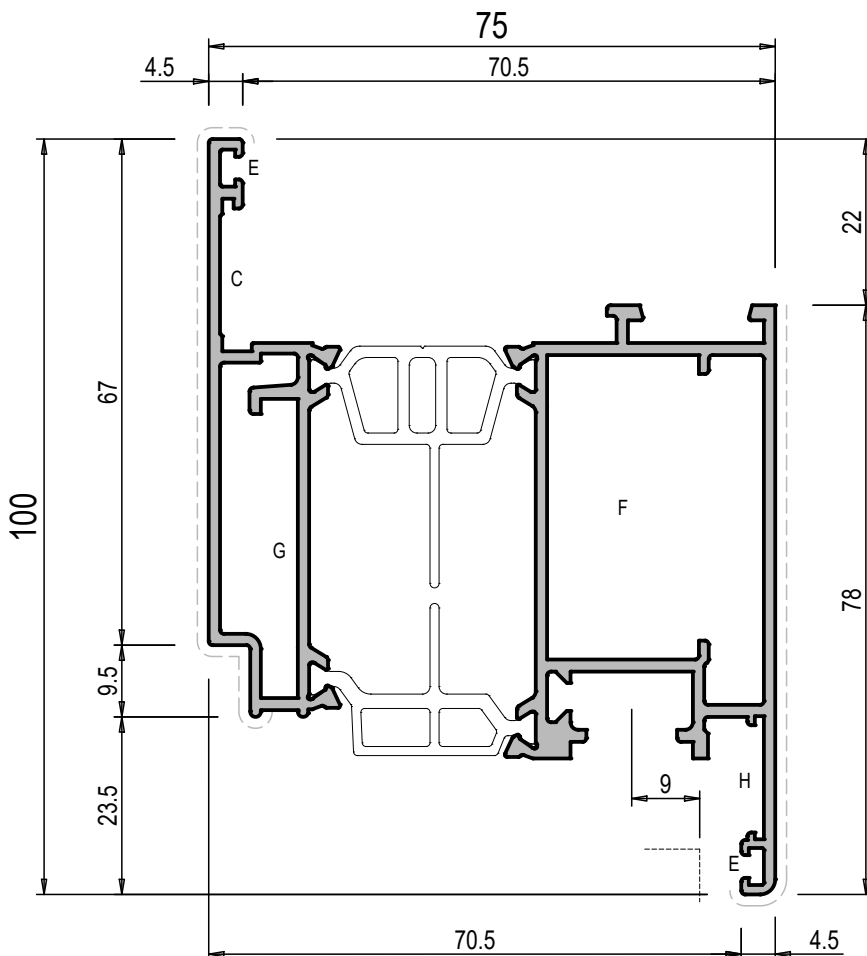

665084

| | | | | | | |
|--------------------------|-------|------|-----------------|-----------------|------|-------|
| ANTA MAG. PISTA 16 PIANA | | Jx | cm ⁴ | 34.3 | | |
| PESO | g/m | 2113 | Jy | cm ⁴ | 39.0 | |
| S. VISTA | mm | 166 | Wx | cm ³ | 6.6 | |
| | | | Wy | cm ³ | 9.8 | |
| C | G501N | | | | | |
| E | G112 | | | | | |
| F | TS080 | | | GA101 | | TI001 |
| G | TS081 | | | GA036 | | TI003 |
| H | G268 | | | | | |

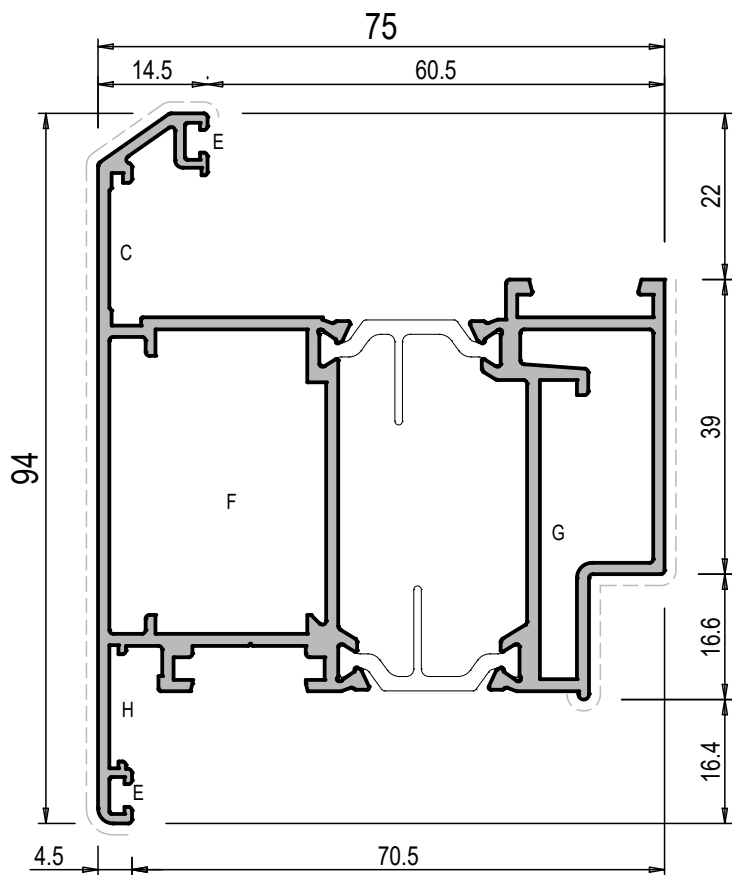

665126

| | | | | | |
|--|-----|------|-----------------|-----------------|------|
| ANTA APERTURA EST. MAG. SGUSCIATA DOPPIA BATTUTA | | Jx | cm ⁴ | 30.1 | |
| PESO | g/m | 2046 | Jy | cm ⁴ | 35.7 |
| S. VISTA | mm | 169 | Wx | cm ³ | 6.3 |
| | | | Wy | cm ³ | 9.1 |

| | | | | | |
|---|--|-------|-------|-------|--|
| C | | G501N | | | |
| E | | G112 | | | |
| F | | TS080 | GA101 | TI001 | |
| G | | TS081 | GA036 | TI003 | |
| H | | G268 | | | |

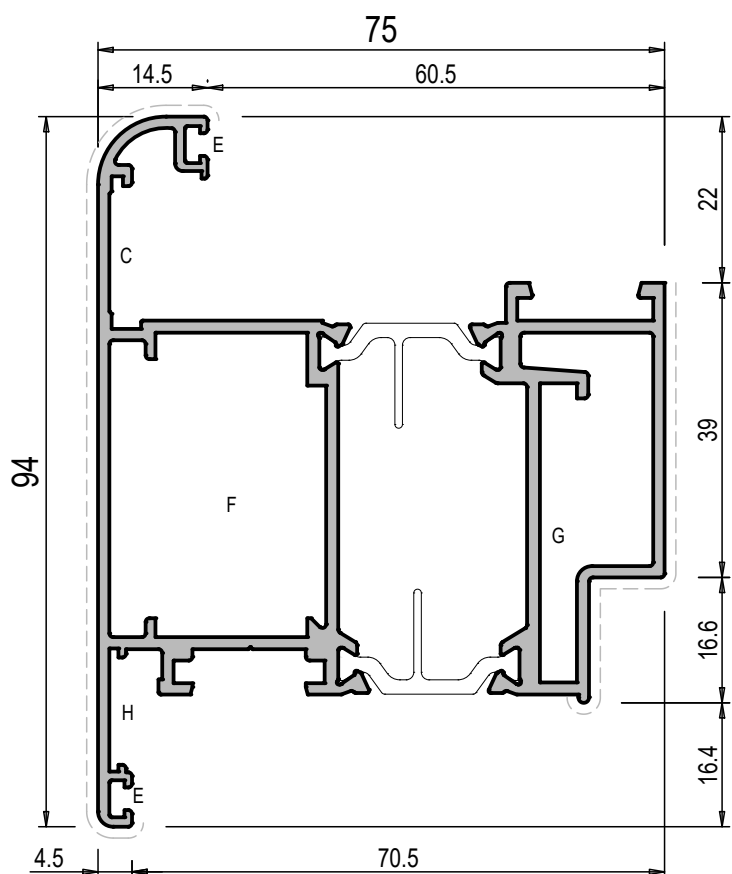

665127

| | | | | | |
|---|-----|------|-----------------|-----------------|------|
| ANTA APERTURA EST. MAG. ARROT. DOPPIA BATTUTA | | Jx | cm ⁴ | 30.1 | |
| PESO | g/m | 2049 | Jy | cm ⁴ | 35.7 |
| S. VISTA | mm | 169 | Wx | cm ³ | 6.3 |
| | | | Wy | cm ³ | 9.1 |

| | | | | | |
|---|--|-------|-------|-------|--|
| C | | G501N | | | |
| E | | G112 | | | |
| F | | TS080 | GA101 | TI001 | |
| G | | TS081 | GA036 | TI003 | |
| H | | G268 | | | |

ANTE

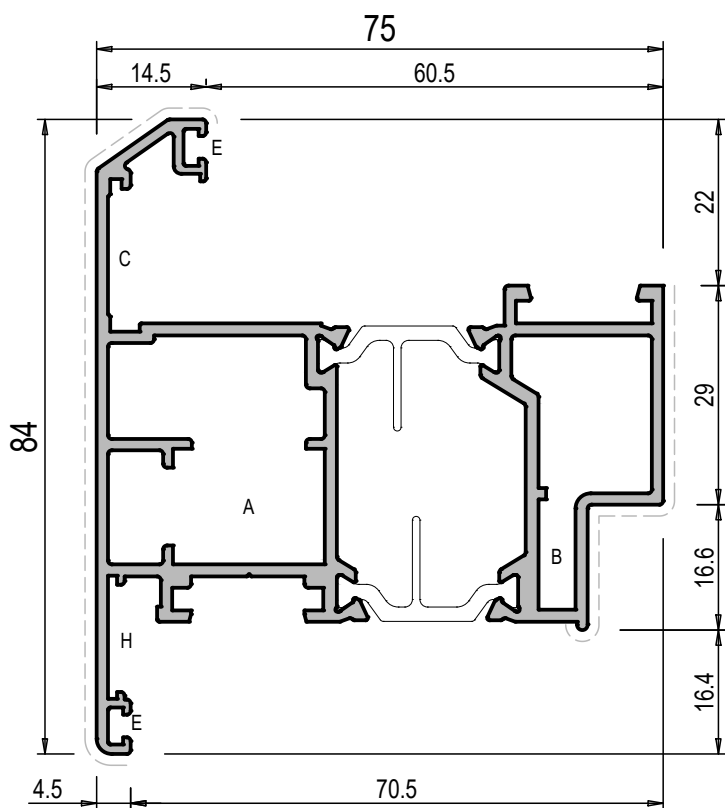

665128

| | | | |
|---|------|-----------------------|------|
| ANTA APERTURA ESTERNA SGUSCIATA DOPPIA BATTUTA | | Jx cm ⁴ | 18.9 |
| PESO g/m | 1858 | Jy cm ⁴ | 31.5 |
| S. VISTA mm | 169 | Wx cm ³ | 4.2 |
| | | Wy cm ³ | 7.7 |

| | | | | | | |
|---|--|-------|--|-------|-------|-------|
| C | | G501N | | | | |
| E | | G112 | | | | |
| A | | TS078 | | TS077 | GA101 | TI001 |
| B | | TS079 | | | GA036 | TI003 |
| H | | G268 | | | | |

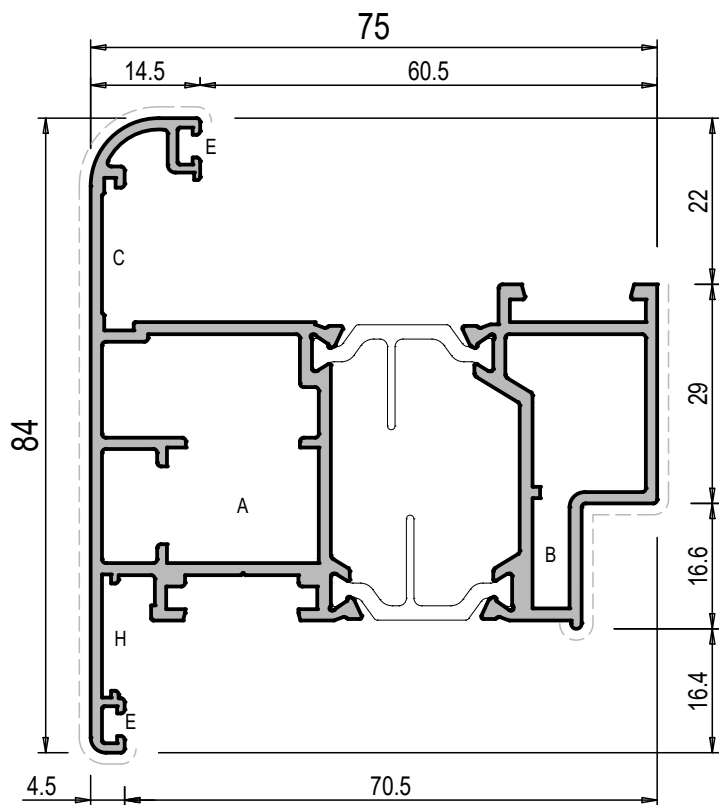

665129

| | | | |
|--|------|-----------------------|------|
| ANTA APERTURA ESTERNA ARROT. DOPPIA BATTUTA | | Jx cm ⁴ | 18.9 |
| PESO g/m | 1862 | Jy cm ⁴ | 31.5 |
| S. VISTA mm | 169 | Wx cm ³ | 4.2 |
| | | Wy cm ³ | 7.7 |

| | | | | | | |
|---|--|-------|--|-------|-------|-------|
| C | | G501N | | | | |
| E | | G112 | | | | |
| A | | TS078 | | TS077 | GA101 | TI001 |
| B | | TS079 | | | GA036 | TI003 |
| H | | G268 | | | | |

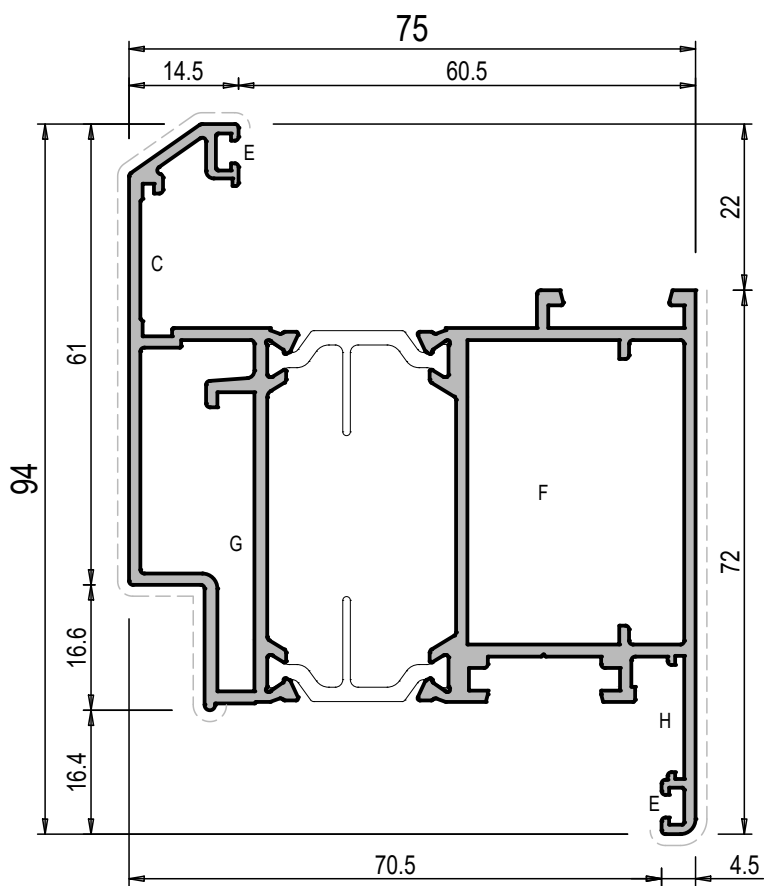

665130

| | | | | | |
|--|-----|------|-----------------|-----------------|------|
| ANTA APERTURA INT. MAG. SGUSCIATA DOPPIA BATTUTA | | Jx | cm ⁴ | 28.7 | |
| PESO | g/m | 2006 | Jy | cm ⁴ | 35.7 |
| S. VISTA | mm | 169 | Wx | cm ³ | 6.3 |
| | | | Wy | cm ³ | 9.1 |

| | | | | | | |
|---|--|-------|--|-------|--|-------|
| C | | G501N | | | | |
| E | | G112 | | | | |
| F | | TS080 | | GA101 | | TI001 |
| G | | TS081 | | GA036 | | TI003 |
| H | | G268 | | | | |

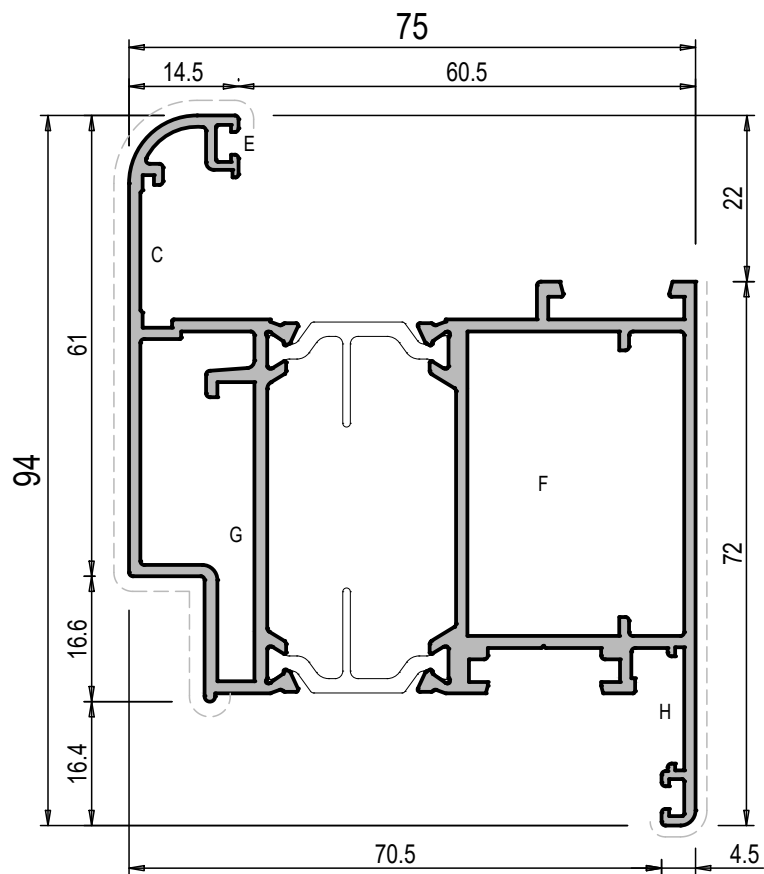

665131

| | | | | | |
|---|-----|------|-----------------|-----------------|------|
| ANTA APERTURA INT. MAG. ARROT. DOPPIA BATTUTA | | Jx | cm ⁴ | 28.7 | |
| PESO | g/m | 2009 | Jy | cm ⁴ | 35.7 |
| S. VISTA | mm | 169 | Wx | cm ³ | 6.3 |
| | | | Wy | cm ³ | 9.1 |

| | | | | | | |
|---|--|-------|--|-------|--|-------|
| C | | G501N | | | | |
| E | | G112 | | | | |
| F | | TS080 | | GA101 | | TI001 |
| G | | TS081 | | GA036 | | TI003 |
| H | | G268 | | | | |

ANTE

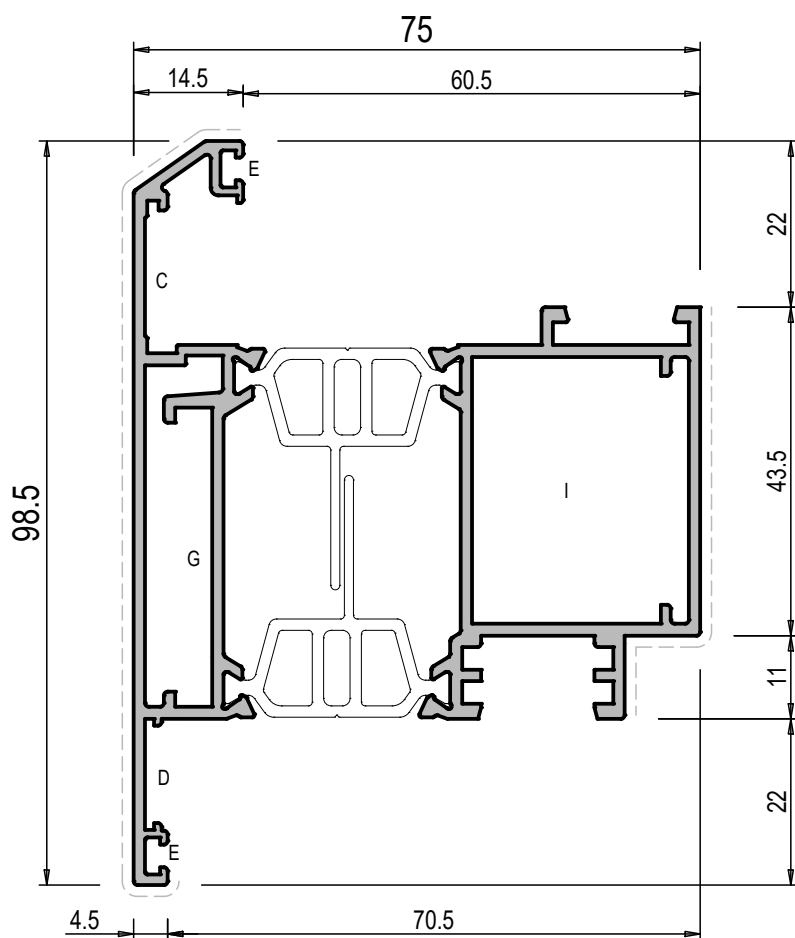

665016

| | | | |
|--------------------------------|------|-----------------------|------|
| ANTA APERTURA BILICO SGUSCIATA | | Jx cm ⁴ | 30.8 |
| PESO g/m | 2124 | Jy cm ⁴ | 35.7 |
| S. VISTA mm | 175 | Wx cm ³ | 6.2 |
| | | Wy cm ³ | 7.9 |

| | | | | | | |
|---|--|-------|--|-------|--|-------|
| C | | G501N | | | | |
| D | | G269 | | | | |
| E | | G112 | | GA101 | | TI001 |
| G | | TS081 | | GA036 | | TI003 |
| I | | G2007 | | | | |

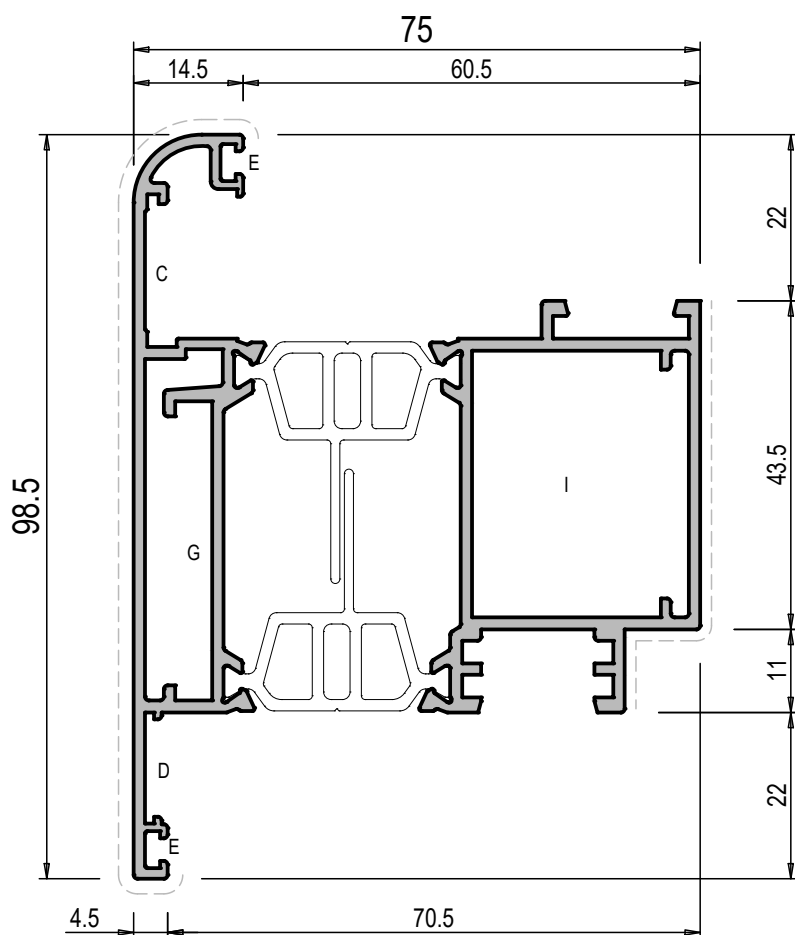

665064

| | | | |
|----------------------------------|------|-----------------------|------|
| ANTA APERTURA BILICO ARROTONDATA | | Jx cm ⁴ | 31.1 |
| PESO g/m | 2128 | Jy cm ⁴ | 35.8 |
| S. VISTA mm | 179 | Wx cm ³ | 6.3 |
| | | Wy cm ³ | 8.0 |

| | | | | | | |
|---|--|-------|--|-------|--|-------|
| C | | G501N | | | | |
| D | | G269 | | | | |
| E | | G112 | | GA101 | | TI001 |
| G | | TS081 | | GA036 | | TI003 |
| I | | G2007 | | | | |

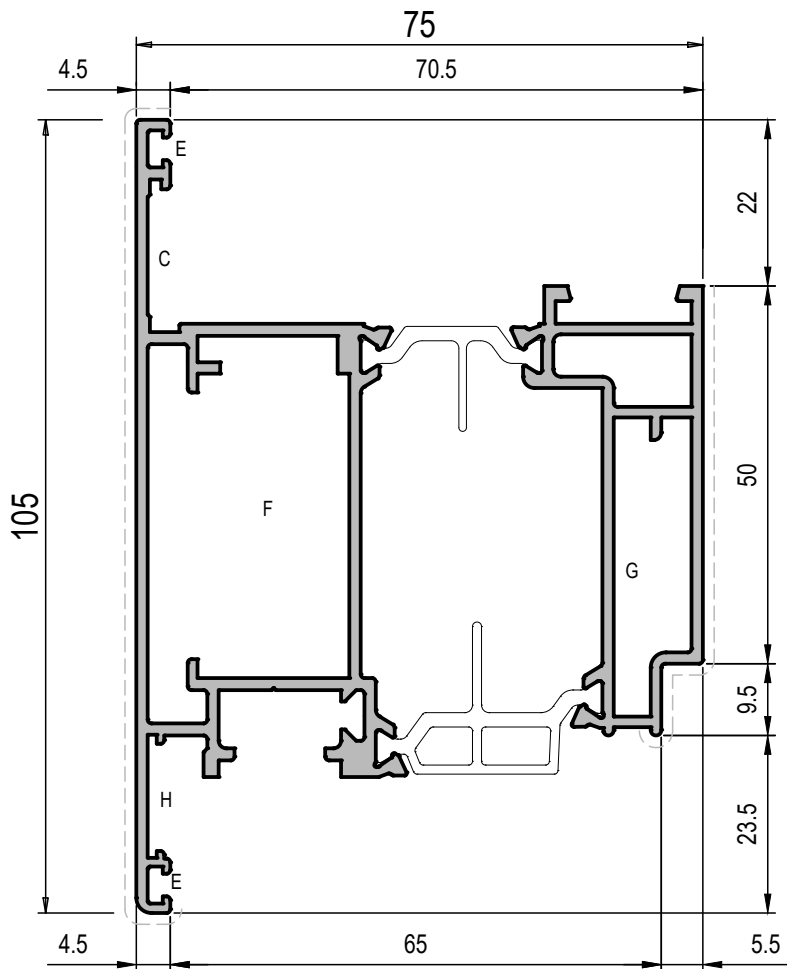

665113

| | | | | |
|---|-------|-----|-----------------|-------|
| ANTA APERTURA EST. MAG. PIANA P.16 DOPPIA BATTUTA | | Jx | cm ⁴ | 40.6 |
| PESO | | Jy | cm ⁴ | 41.3 |
| g/m | 2189 | Wx | cm ³ | 7.7 |
| S. VISTA | | Wy | cm ³ | 13.3 |
| mm | | 179 | | |
| C | G501N | | | |
| E | G112 | | | |
| F | TS080 | | GA101 | TI001 |
| G | TS081 | | GA036 | TI003 |
| H | G268 | | | |

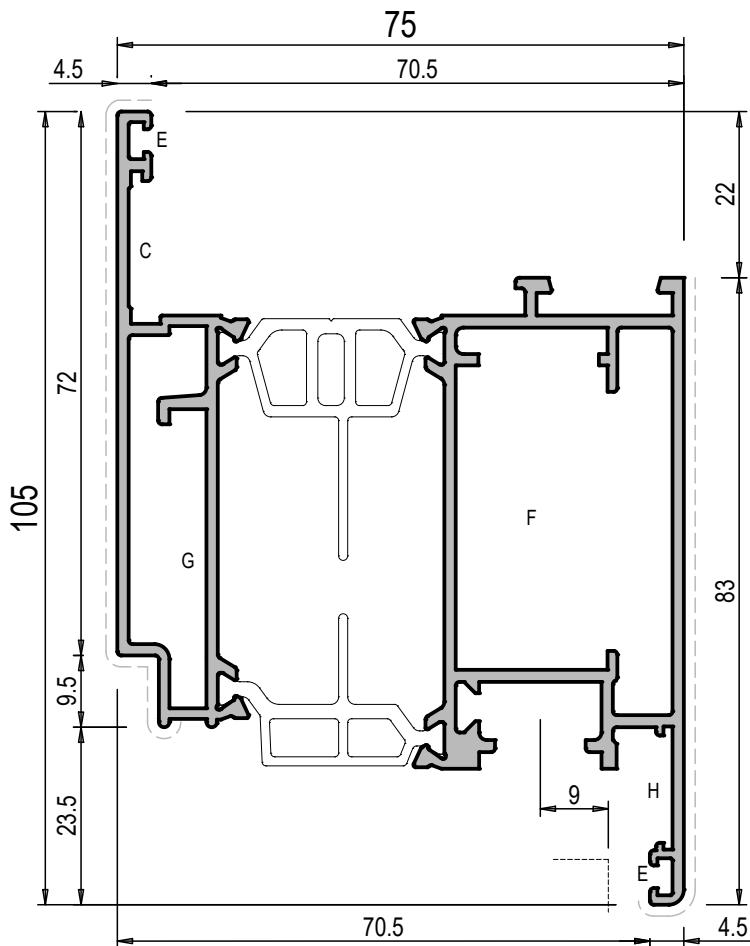

665117

| | | | | |
|-------------------------|-------|-------|-----------------|-------|
| ANTA MAG.PISTA 16 PIANA | | Jx | cm ⁴ | 42 |
| PESO | | Jy | cm ⁴ | 41.3 |
| g/m | 2308 | Wx | cm ³ | 7.7 |
| S. VISTA | | Wy | cm ³ | 10.5 |
| mm | | 175.5 | | |
| C | G501N | | | |
| E | G112 | | | |
| F | TS080 | | GA101 | TI001 |
| G | TS081 | | GA036 | TI003 |
| H | G268 | | | |

ANTE

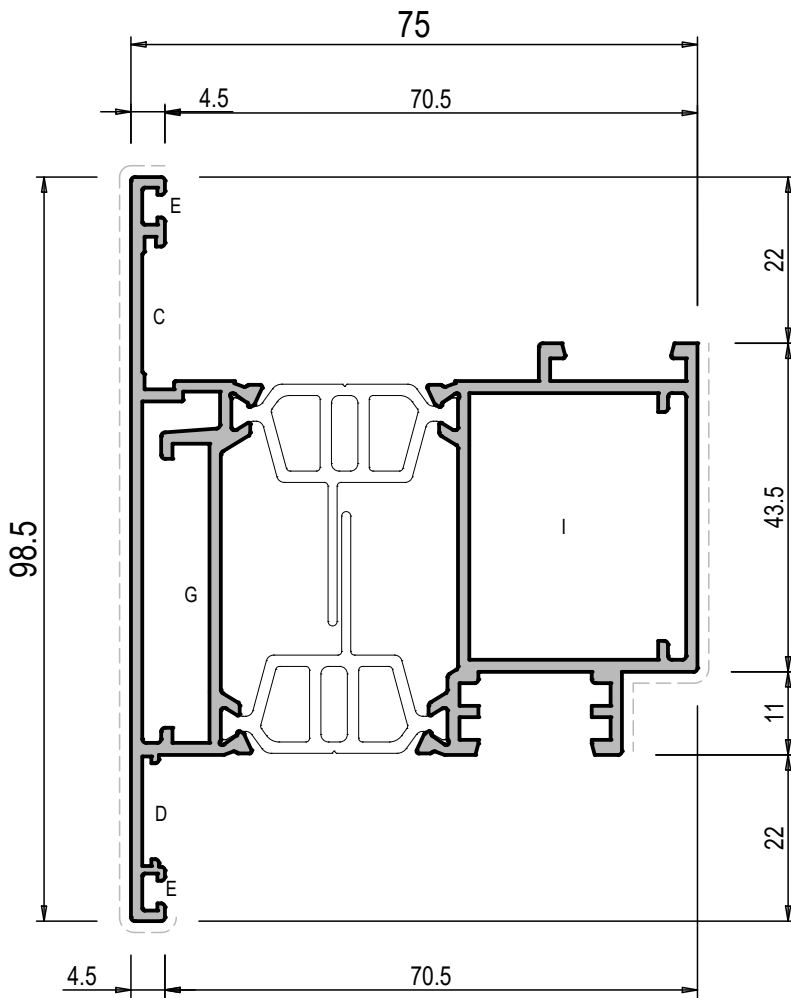

665114

| ANTA APERTURA BILICO PIANA | | Jx cm ⁴ | 30.1 |
|-------------------------------|------|-----------------------|------|
| PESO g/m | 2073 | Jy cm ⁴ | 35.7 |
| S. VISTA mm | 165 | Wx cm ³ | 5.6 |
| | | Wy cm ³ | 10.5 |

| | | | | | |
|---|--|-------|--|--|-----------------|
| C | | G501N | | | GA101 TI001 |
| D | | G269 | | | |
| E | | G112 | | | |
| G | | TS081 | | | |
| I | | G2007 | | | |

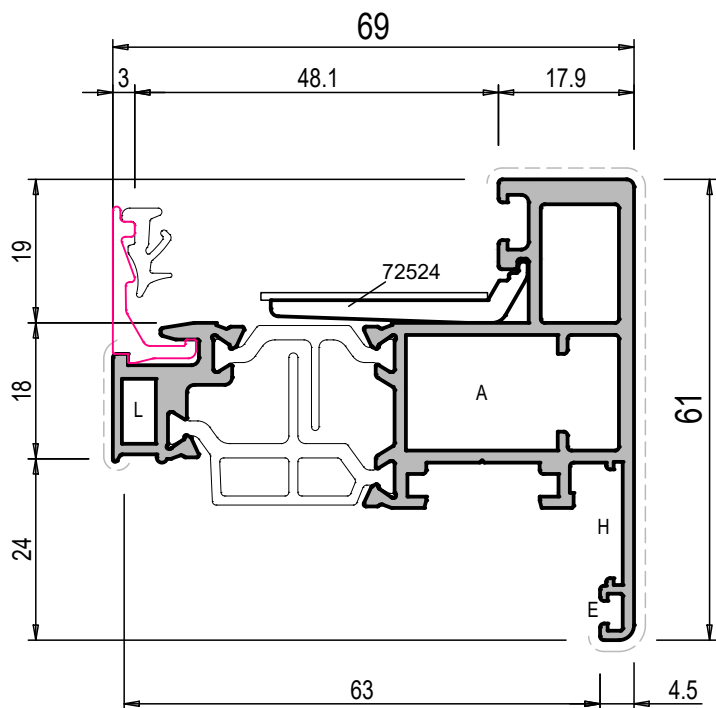

665121

| | | | | | |
|----------------------|-----|------|-----------------|-----------------|------|
| ANTA "Z" A SCOMPARSA | | Jx | cm ⁴ | 8.2 | |
| PESO | g/m | 1556 | Jy | cm ⁴ | 2.4 |
| S. VISTA | mm | 96 | Wx | cm ³ | 22.6 |
| | | | Wy | cm ³ | 5.9 |

| | | | | | | |
|---|--|-------|--|-------|-------|-------|
| A | | TS078 | | TS077 | GA101 | TI001 |
| E | | G112 | | | | |
| H | | G268 | | | | |
| L | | TS206 | | | | |

N.B. SOLO SOLUZIONE AD 1 ANTA

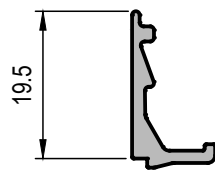

665438

| | | | | | |
|----------------------------|-----|------|-----------------|-----------------|---|
| FERAVETRO ANTA A SCOMPARSA | | Jx | cm ⁴ | . | |
| PESO | g/m | 161 | Jy | cm ⁴ | . |
| S. VISTA | mm | ---- | Wx | cm ³ | . |
| | | | Wy | cm ³ | . |

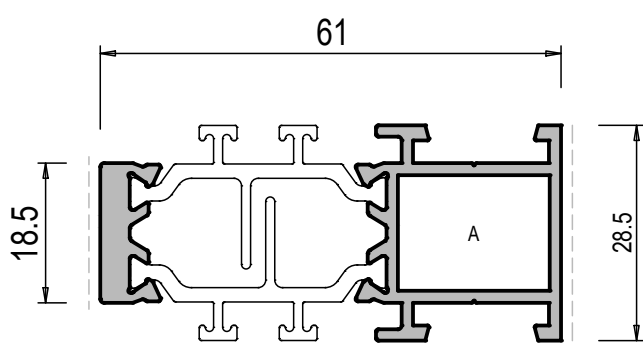

665122

| | | | | | |
|--------------------------|-----|------|-----------------|-----------------|------|
| RIPORTO ANTA A SCOMPARSA | | Jx | cm ⁴ | 2.8 | |
| PESO | g/m | 1031 | Jy | cm ⁴ | 13.3 |
| S. VISTA | mm | 47 | Wx | cm ³ | 1.4 |
| | | | Wy | cm ³ | 4.2 |

| | | | | | | |
|---|--|-------|--|-------|-------|-------|
| A | | TS078 | | TS077 | GA101 | TI001 |
| | | | | | GA036 | TI003 |
| | | | | | | |

RIPORTO

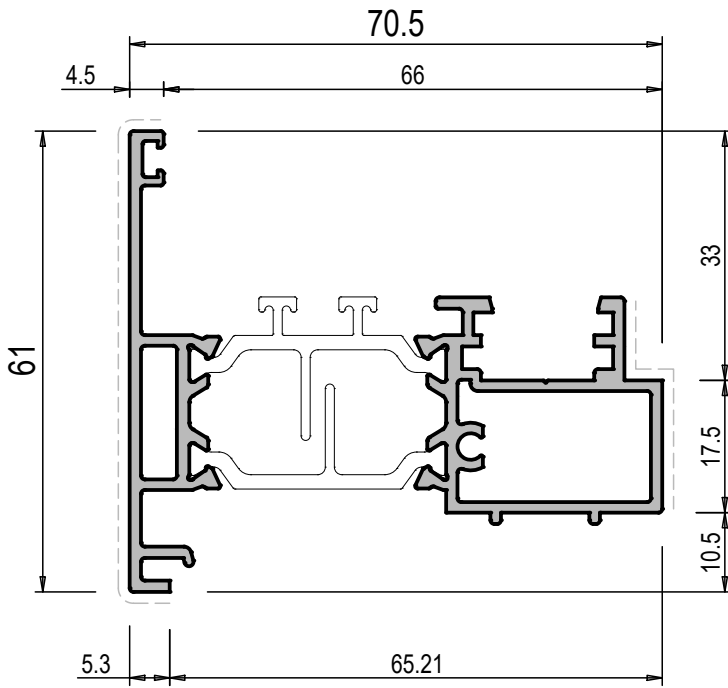

665003

| RIPORTO PIANO | | Jx | 6.0 |
|---------------|-------|-----------|------|
| PESO | 1340 | Jy | 21.2 |
| S. VISTA | 102 | Wx | 1.7 |
| mm | | Wy | 5.1 |
| J | TT065 | CP. TAPPI | |
| | | | |
| | | | |
| | | | |
| | | | |

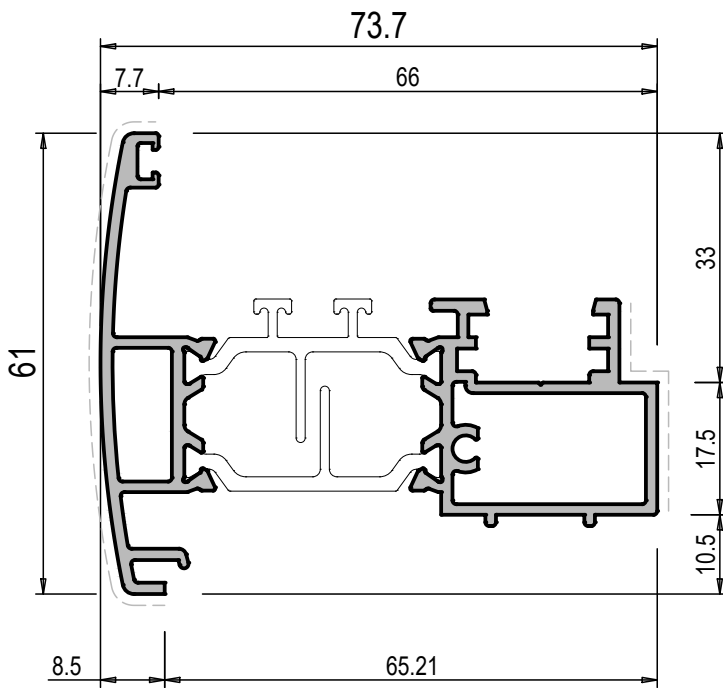

665017

| RIPORTO ARROTONDATO | | Jx | 6.7 |
|---------------------|-------|-----------|------|
| PESO | 1393 | Jy | 23.0 |
| S. VISTA | 102 | Wx | 1.8 |
| mm | | Wy | 5.3 |
| J | TT065 | CP. TAPPI | |
| | | | |
| | | | |
| | | | |
| | | | |

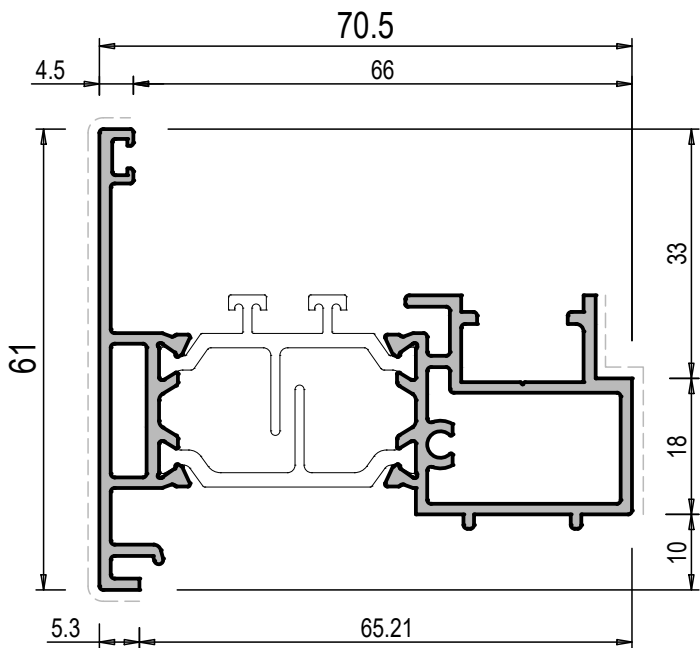

665018

| | | | | | |
|-------------------------------|-------|-----------|-----------------|-----------------|------|
| RIPORTO PIANO PISTA 16 INT. 9 | | Jx | cm ⁴ | 6.1 | |
| PESO | g/m | 1348 | Jy | cm ⁴ | 21.3 |
| S. VISTA | mm | 104 | Wx | cm ³ | 1.7 |
| | | | Wy | cm ³ | 5.1 |
| K | TT066 | CP. TAPPI | | | |
| | | | | | |
| | | | | | |
| | | | | | |
| | | | | | |

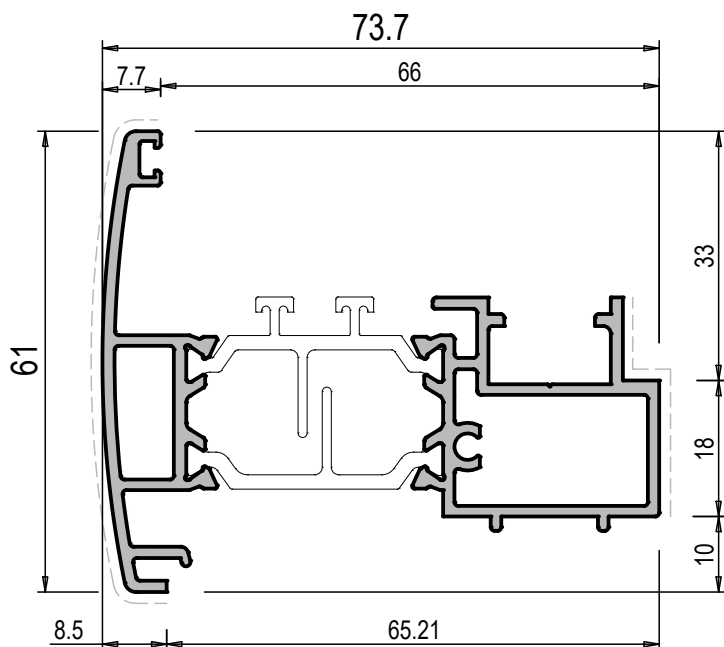

665065

| | | | | | |
|--------------------------------|-------|-----------|-----------------|-----------------|------|
| RIPORTO ARROT. PISTA 16 INT. 9 | | Jx | cm ⁴ | 6.7 | |
| PESO | g/m | 1401 | Jy | cm ⁴ | 23.2 |
| S. VISTA | mm | 104 | Wx | cm ³ | 1.7 |
| | | | Wy | cm ³ | 5.4 |
| K | TT066 | CP. TAPPI | | | |
| | | | | | |
| | | | | | |
| | | | | | |
| | | | | | |

RIPORTO

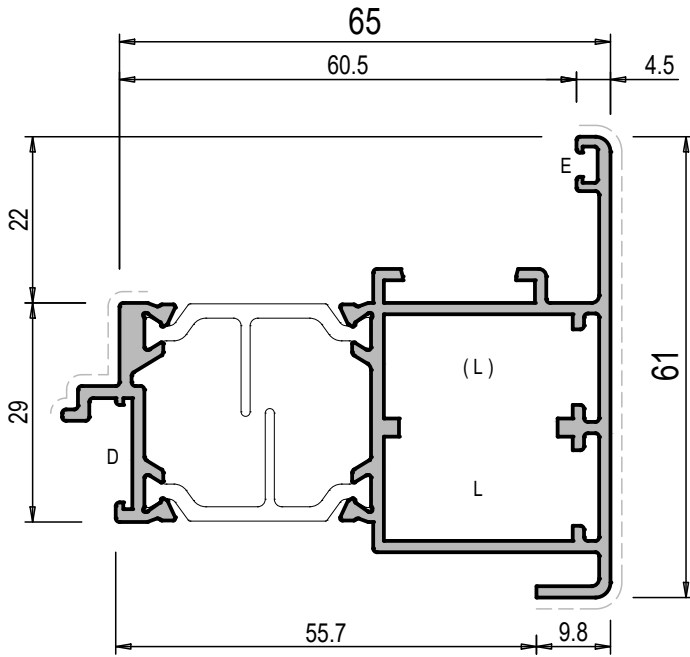

665019

| RIPORTO BILICO | | Jx | 8.2 |
|----------------|-------|-------|-------|
| PESO | 1353 | Jy | 22.2 |
| S. VISTA | 98 | Wx | 2.3 |
| | | Wy | 5.6 |
| D | G269 | GA101 | TI001 |
| E | G112 | | |
| L | TS002 | | |
| | | | |
| | | | |

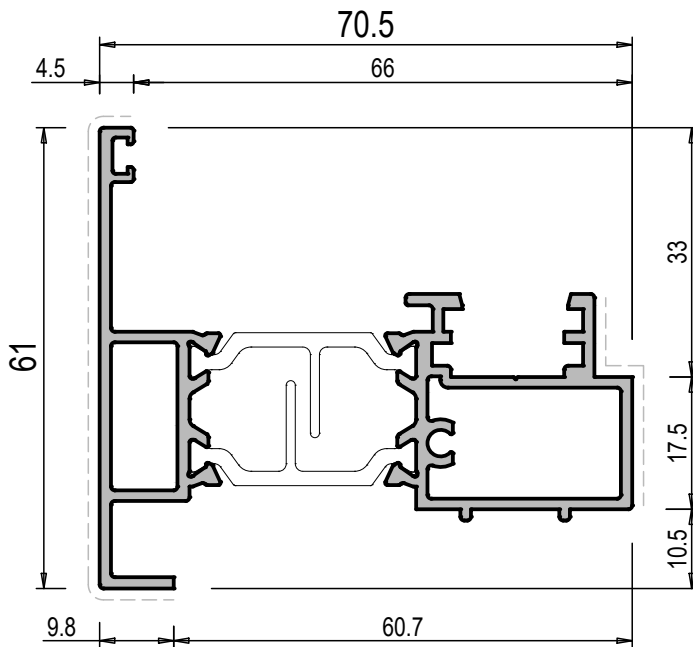

665038

| RIPORTO CENTRALE APERTURA DOPPIA BATTUTA | | Jx | 5.8 |
|--|-------|-----------|-------|
| PESO | 1323 | Jy | 20.1 |
| S. VISTA | 107 | Wx | 1.6 |
| | | Wy | 4.9 |
| W | TT068 | CP. TAPPI | GA101 |
| | | | TI001 |
| | | | |
| | | | |

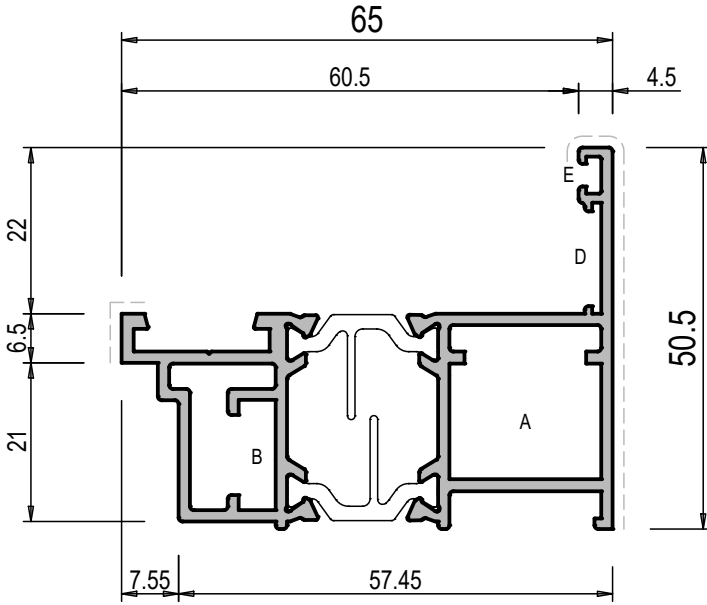

665066

| RIPORTO APERTURA ESTERNA INSERIMENTO IN VETRINA | | Jx cm ⁴ | 5.2 |
|--|------|-----------------------|------|
| PESO g/m | 1229 | Jy cm ⁴ | 13.7 |
| S. VISTA mm | 62 | Wx cm ³ | 1.6 |
| | | Wy cm ³ | 3.9 |

| | | | | | | |
|---|--|-------|--|-------|-------|-------|
| A | | TS078 | | TS077 | GA101 | TI001 |
| B | | TS079 | | | GA036 | TI003 |
| D | | G269 | | | | |
| E | | G112 | | | | |

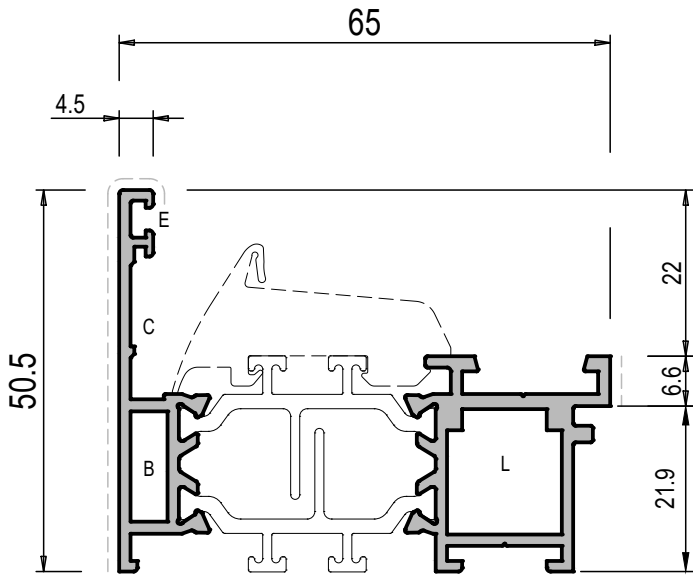

665119

| RIPORTO | | Jx cm ⁴ | 4.6 |
|----------------|------|-----------------------|------|
| PESO g/m | 1210 | Jy cm ⁴ | 17.1 |
| S. VISTA mm | 61.5 | Wx cm ³ | 1.4 |
| | | Wy cm ³ | 4.7 |

| | | | | | | |
|---|--|-------|--|--|-------|-------|
| L | | TS001 | | | GA101 | TI001 |
| B | | TS079 | | | GA036 | TI003 |
| C | | G501N | | | | |
| E | | G112 | | | | |

TRAVERSO

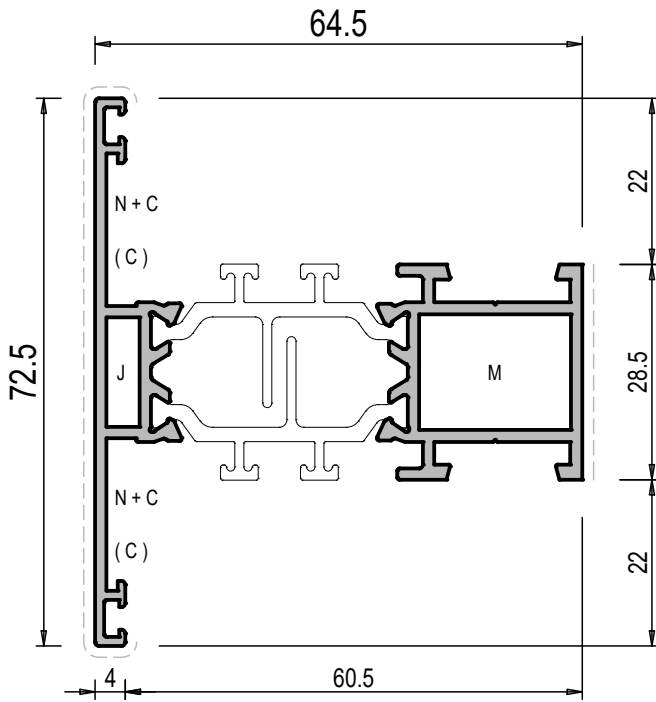

665020

| TRAVERSO CON CAVALLOTTI | | Jx | 6.8 |
|-------------------------|------|----|------|
| PESO | 1294 | Jy | 18.5 |
| S. VISTA | 98 | Wx | 1.9 |
| | | Wy | 4.9 |

| | | | | |
|---|-------|-----------|-------|-------|
| C | G501N | SU TELAIO | | |
| M | G199 | | GA101 | TI002 |
| N | TS082 | SU ANTA | | |
| C | G501N | | | |
| J | TS073 | | GA112 | |

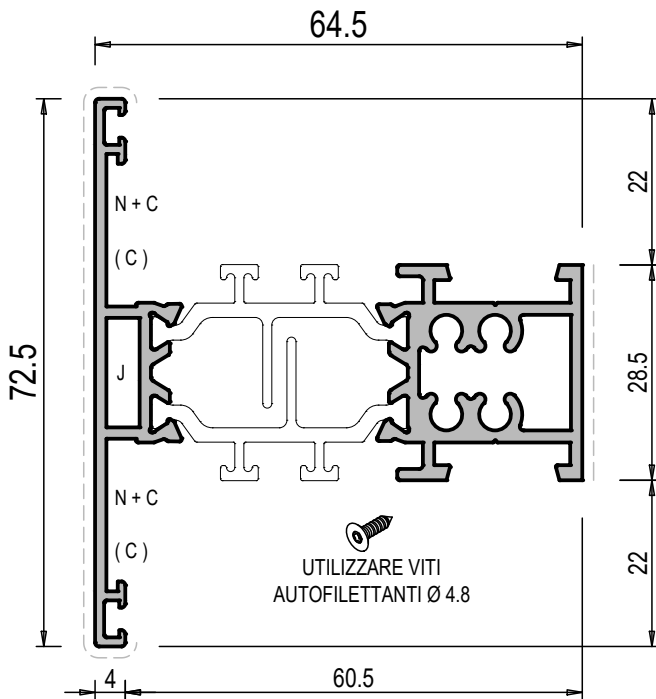

665021

| TRAVERSO CON VITI | | Jx | 7.0 |
|-------------------|------|----|------|
| PESO | 1463 | Jy | 20.7 |
| S. VISTA | 98 | Wx | 1.9 |
| | | Wy | 5.8 |

| | | | | |
|---|-------|-----------|-------|--|
| C | G501N | SU TELAIO | | |
| N | TS082 | SU ANTA | | |
| C | G501N | | | |
| J | TS073 | | GA112 | |

TRAVERSO

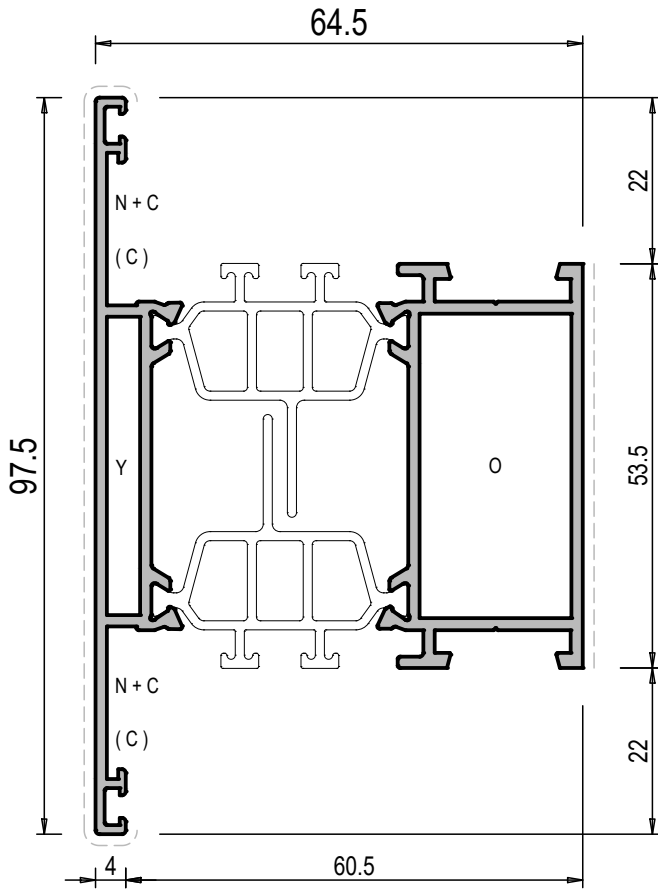

665022

| | | | | |
|--------------------------|-------|-----------|-----------------|-----------------|
| TRAVERSO MAG.CON CAVALL. | | Jx | cm ⁴ | 25.1 |
| PESO | | Jy | cm ⁴ | 25.6 |
| g/m | | 1791 | Wx | cm ³ |
| S. VISTA | | 158 | Wy | cm ³ |
| mm | | | | |
| C | G501N | SU TELAIO | | |
| O | TS083 | | GA101 | TI002 |
| N | TS082 | SU ANTA | | |
| C | G501N | | | |
| Y | TS074 | | GA112 | |

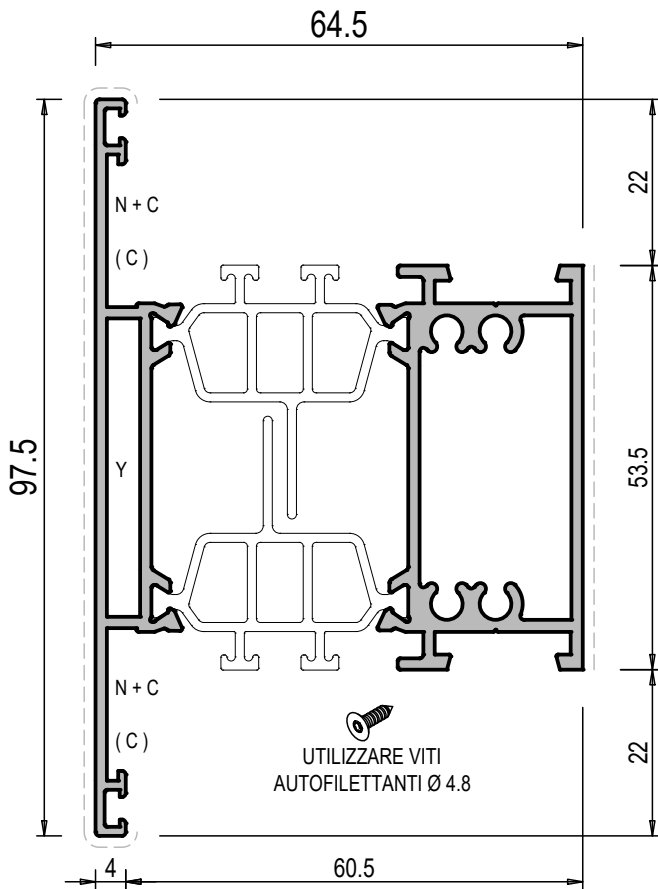

665023

| | | | | |
|-----------------------|-------|-----------|-----------------|-----------------|
| TRAVERSO MAG.CON VITI | | Jx | cm ⁴ | 26.6 |
| PESO | | Jy | cm ⁴ | 27.7 |
| g/m | | 1961 | Wx | cm ³ |
| S. VISTA | | 158 | Wy | cm ³ |
| mm | | | | |
| C | G501N | SU TELAIO | | |
| N | TS082 | SU ANTA | | |
| C | G501N | | | |
| Y | TS074 | | GA112 | |

Profilati Scala 1:1



TRAVERSO

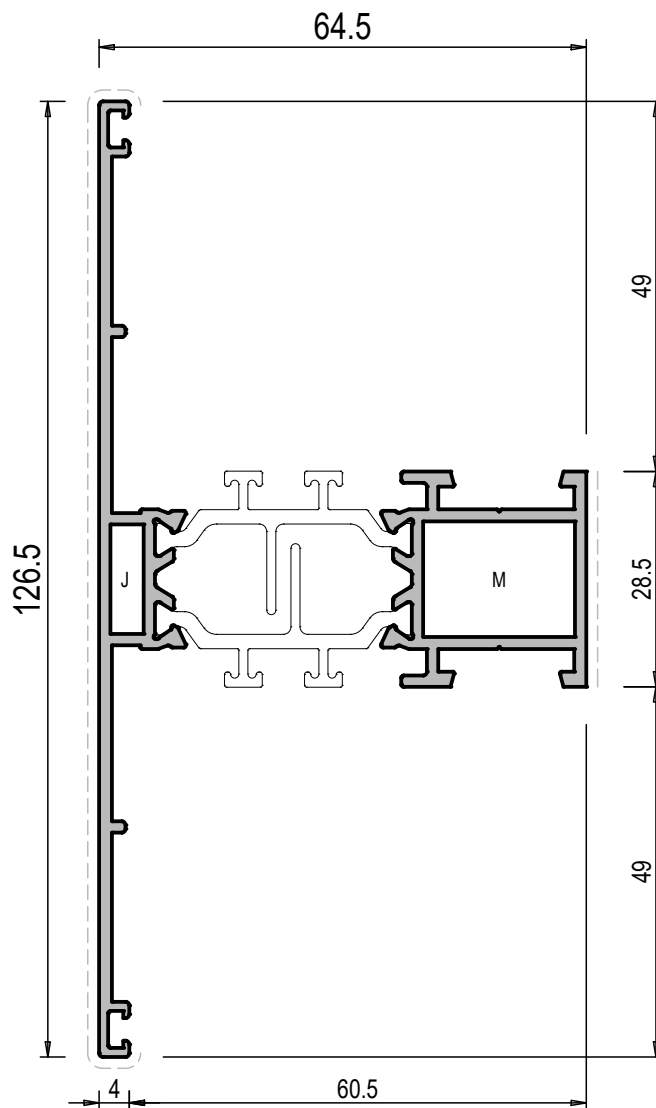

665123

| | | | | |
|---------------------------|------|--|-----------------------|------|
| TRAVERSO ANTA A SCOMPARSA | | | Jx cm ⁴ | 25.2 |
| PESO g/m | 1557 | | Jy cm ⁴ | 22.4 |
| S. VISTA mm | 98 | | Wx cm ³ | 4.2 |
| | | | Wy cm ³ | 5.6 |

| | | | | | |
|---|--|-------|--|-------|-------|
| M | | G199 | | GA101 | T1002 |
| J | | TS073 | | GA112 | |

ZOCCOLO RIPORTATO

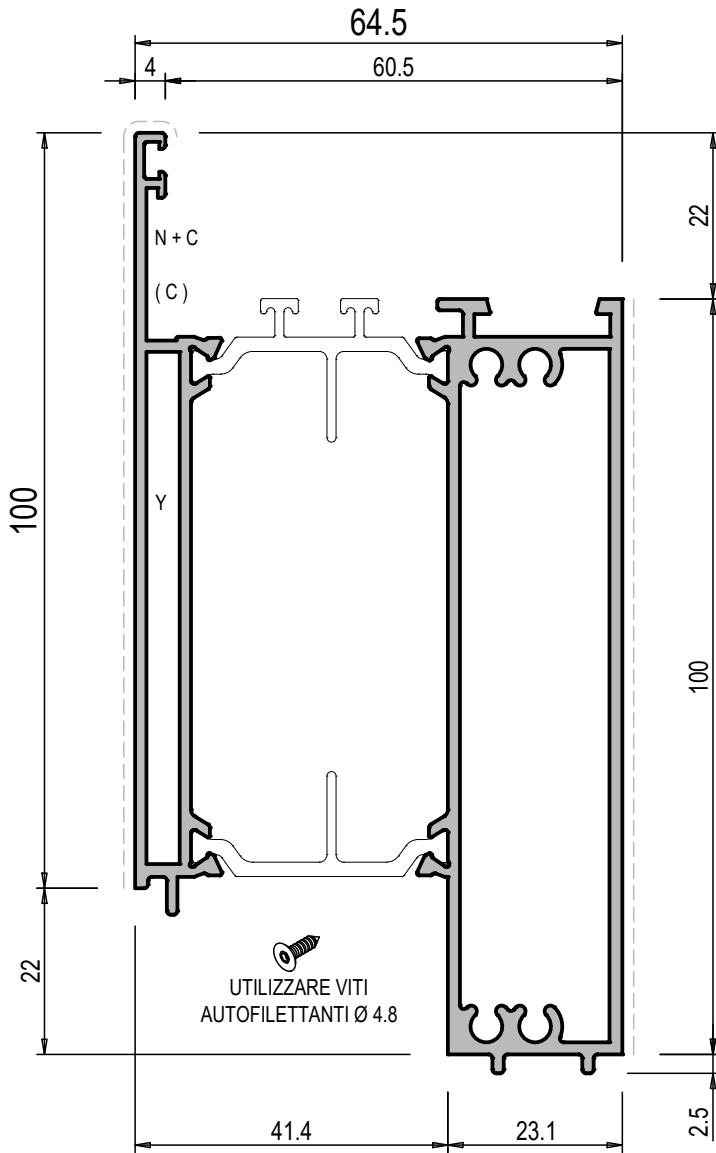

665024

| ZOCCOLO RIPORTATO | | Jx | 81.4 |
|-------------------|-------|-----------|------|
| PESO | 2403 | Jy | 37.0 |
| S. VISTA | 204 | Wx | 12.7 |
| | | Wy | 11.3 |
| C | G501N | SU TELAIO | |
| N | TS082 | SU ANTA | |
| C | G501N | | |
| Y | TS074 | GA112 | |

ZOCCOLO RIPORTATO

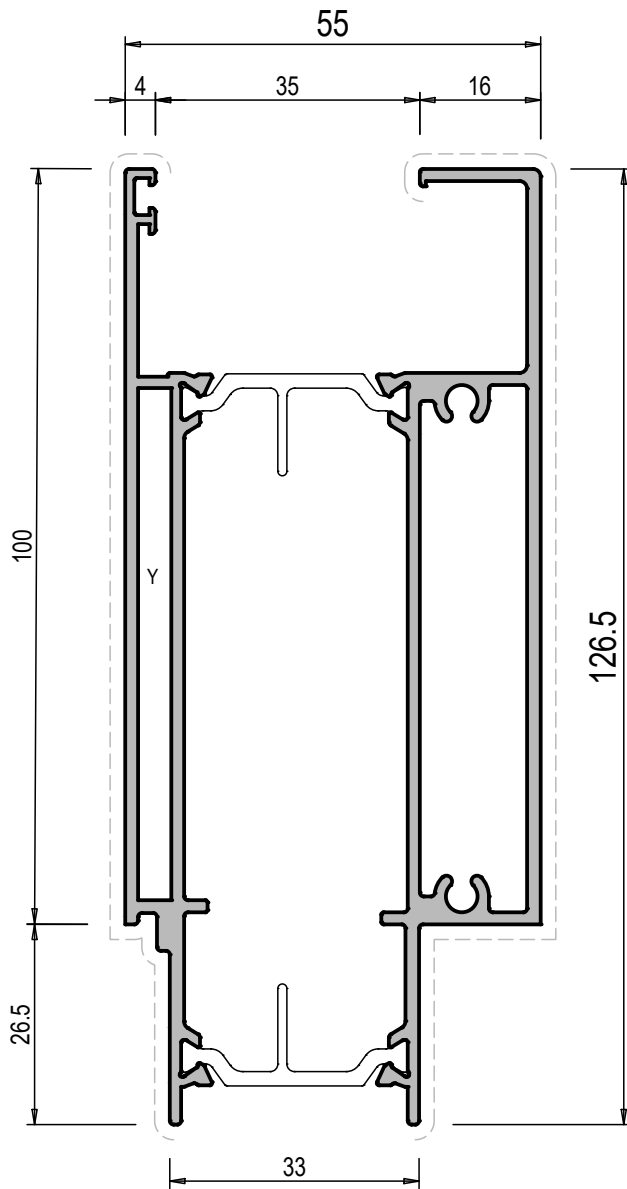

665097

| ZOCCOLO RIPORTATO V.I. | | Jx cm ⁴ | 29.2 |
|------------------------|-------|-----------------------|---|
| PESO g/m | 2541 | Jy cm ⁴ | 97.0 |
| S. VISTA mm | 296 | Wx cm ³ | 10.1 |
| | | Wy cm ³ | 15.0 |
| Y | TS074 | GA112 |  |
| | | | |
| | | | |
| | | | |

 UTILIZZARE VITI
 AUTOFILETTANTI Ø 4.8

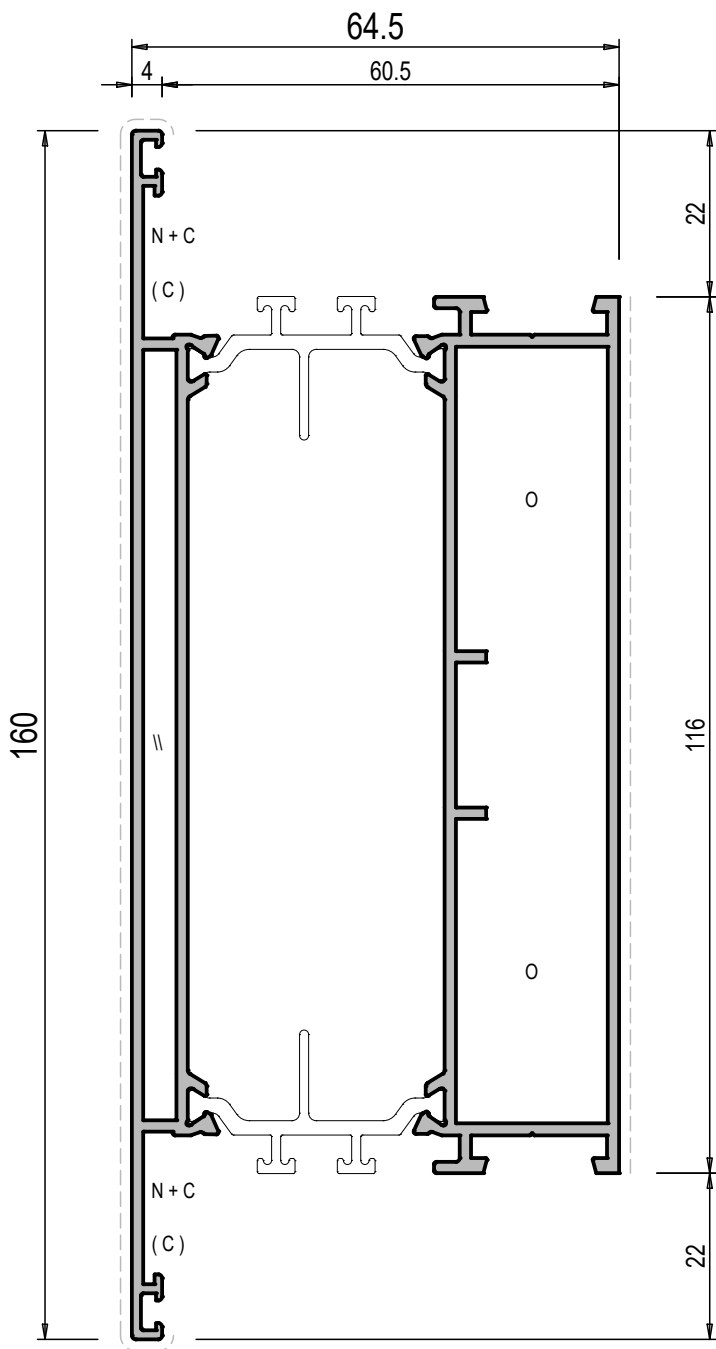

665025

| FASCIA CON CAVALLOTTI | | Jx | 152.9 |
|-----------------------|------|----|-------|
| PESO | 2910 | Jy | 44.1 |
| S. VISTA | 284 | Wx | 19.1 |
| | | Wy | 11.7 |

| | | | | |
|---|-------|-----------|-------|-------|
| C | G501N | SU TELAIO | | |
| O | TS083 | | GA101 | TI002 |
| N | TS082 | SU ANTA | | |
| C | G501N | | | |
| | TS088 | | GA112 | |

FASCIA

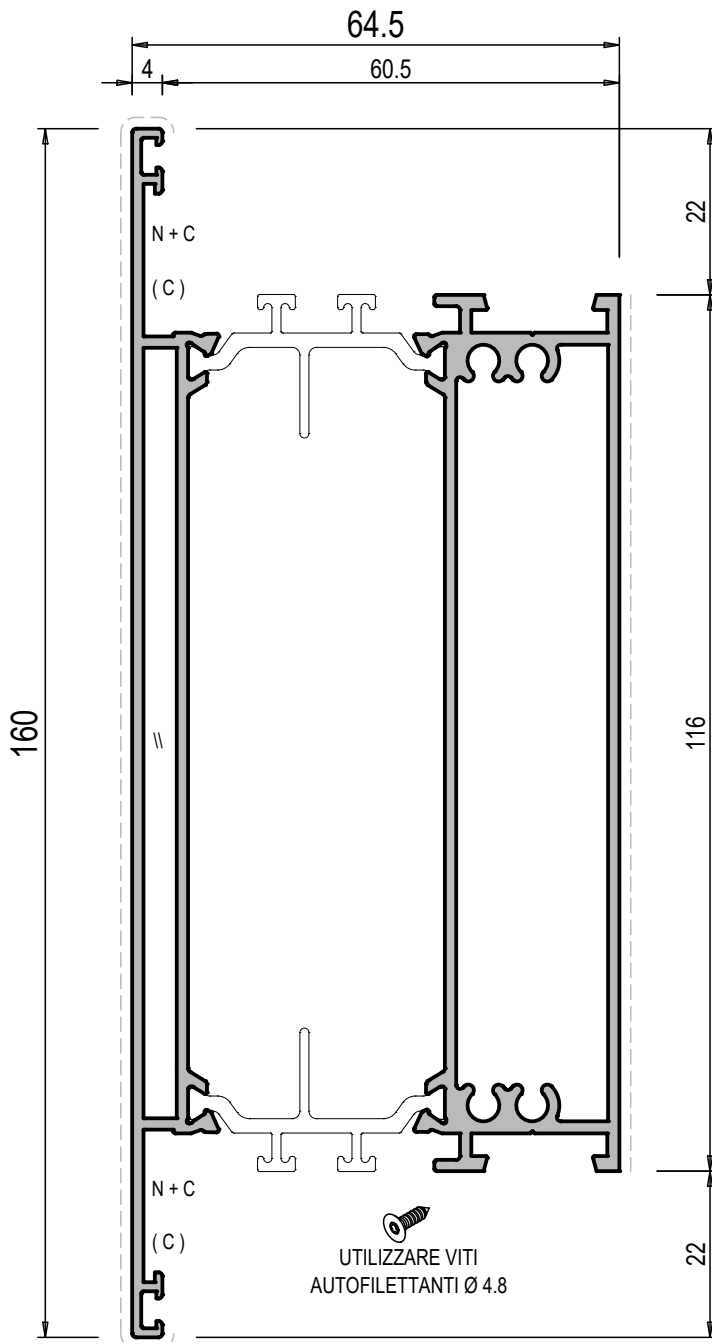

665026

| FASCIA CON VITI | | Jx | 163.3 |
|-----------------|------|----|-------|
| PESO | 2936 | Jy | 45.3 |
| S. VISTA | 284 | Wx | 20.4 |
| | | Wy | 12.6 |

| | | | | |
|----|-------|-----------|-------|--|
| C | G501N | SU TELAIO | | |
| N | TS082 | SU ANTA | | |
| C | G501N | | | |
| // | TS088 | | GA112 | |

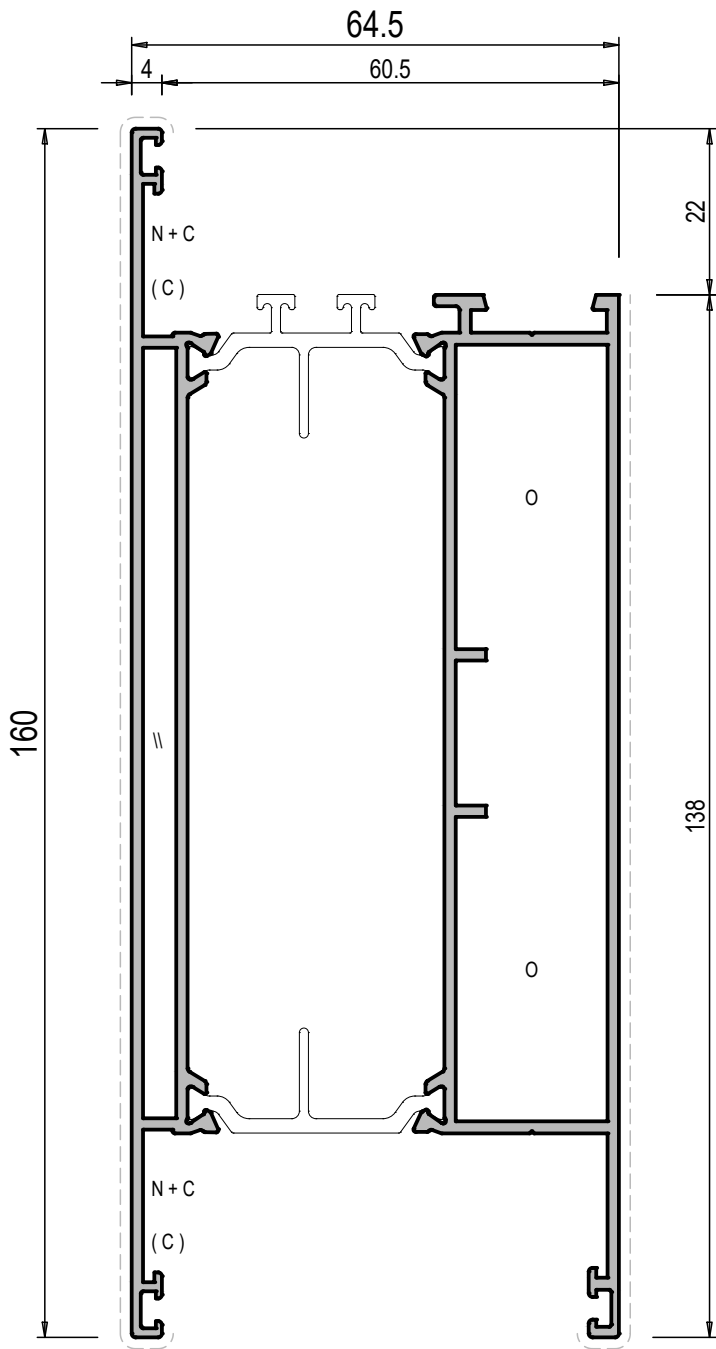

665027

| ZOCCOLO CON CAVALLOTTI | | Jx | 156.8 |
|------------------------|------|----|-------|
| PESO | 2915 | Jy | 46.3 |
| S. VISTA | 314 | Wx | 19.5 |
| | | Wy | 12.8 |

| | | | | |
|---|-------|-----------|-------|-------|
| C | G501N | SU TELAIO | | |
| O | TS083 | | GA101 | TI002 |
| N | TS082 | SU ANTA | | |
| C | G501N | | | |
| ∥ | TS088 | | GA112 | |

ZOCCOLO

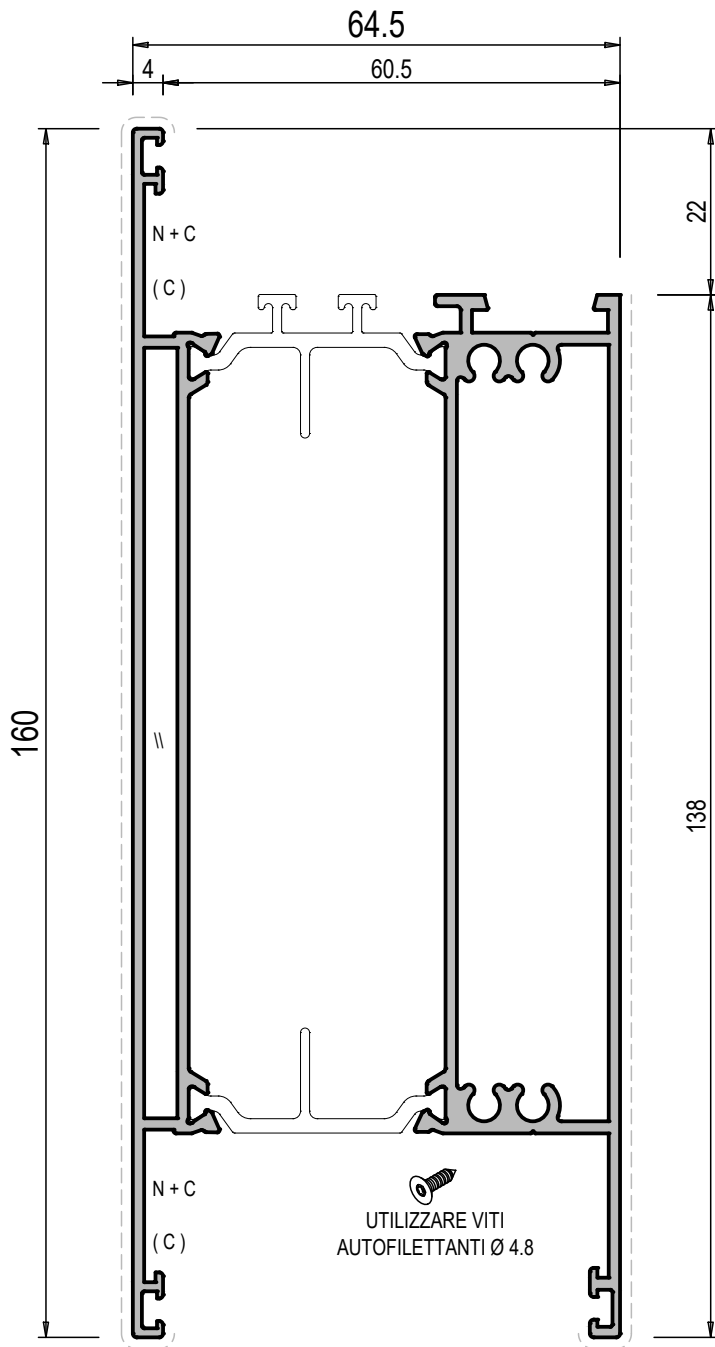

665028

| ZOCCOLO CON VITI | | Jx | 167.3 |
|------------------|-------|-----------|-------|
| PESO | 3019 | Jy | 48.0 |
| S. VISTA | 314 | Wx | 20.9 |
| | | Wy | 13.6 |
| C | G501N | SU TELAIO | |
| N | TS082 | SU ANTA | |
| C | G501N | | |
| | TS088 | | GA112 |
| | | | |

FASCIA

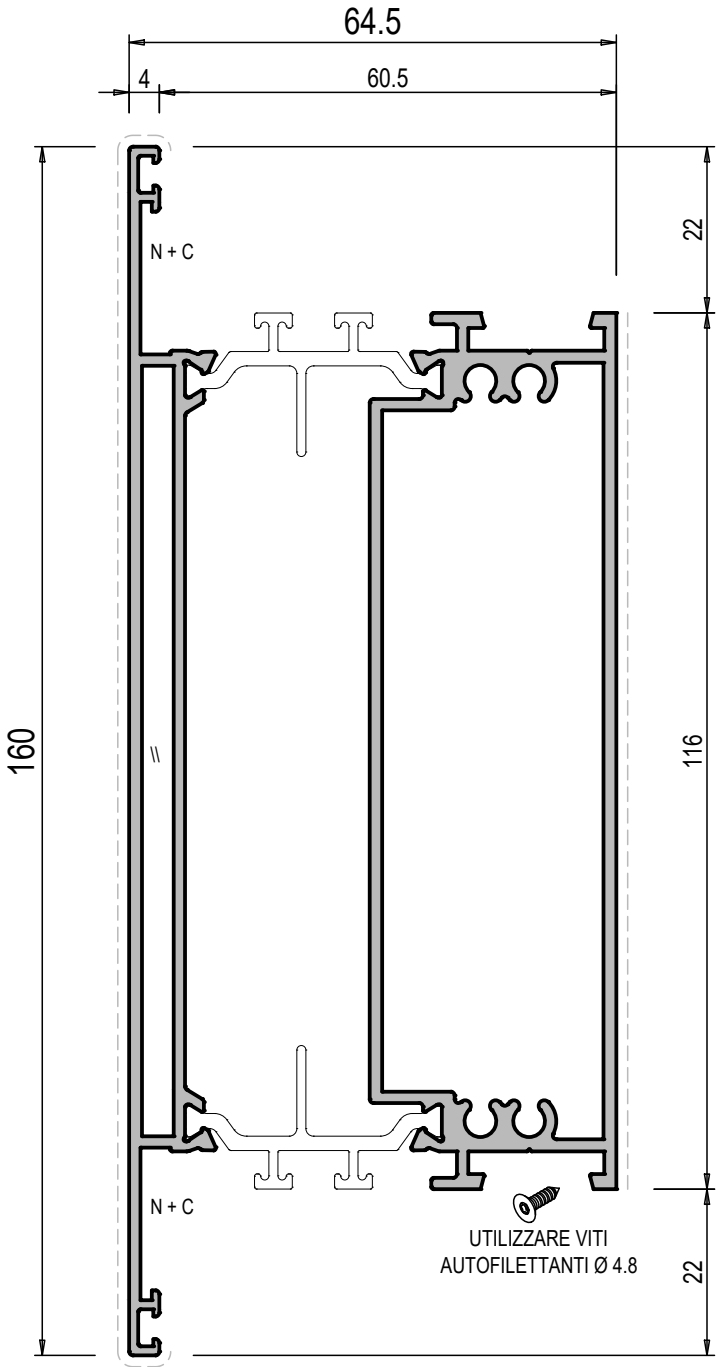

665099

| | | | |
|----------------------|------|-----------------------|-------|
| FASCIA PER SERRATURE | | Jx cm ⁴ | 167.3 |
| PESO g/m | 3099 | Jy cm ⁴ | 49.7 |
| S. VISTA mm | 286 | Wx cm ³ | 21.0 |
| | | Wy cm ³ | 14 |

| | | | | | |
|---|--|-------|---------|-------|--|
| | | | | | |
| N | | TS082 | SU ANTA | GA112 | |
| C | | G501N | | | |
| | | TS088 | | | |

Profilati Scala 1:1



TRAVERSO ANTA PIANA

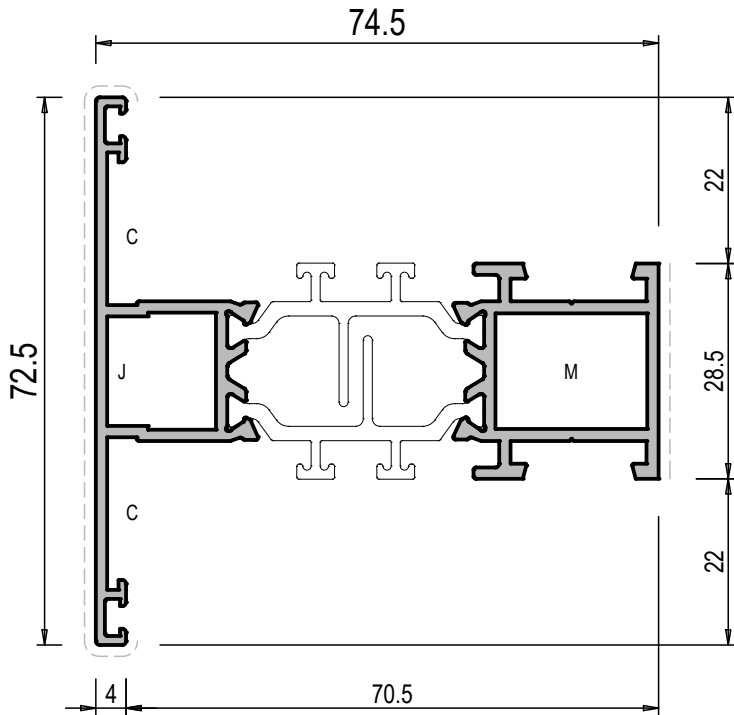

665041

| TRAVERSO PER ANTA PIANA CON CAVALLOTTI | | | Jx | 7.0 |
|---|-------|-----------|-------|-------|
| PESO | 1378 | | Jy | 25.2 |
| S. VISTA | 108 | | Wx | 1.9 |
| mm | | | Wy | 6.1 |
| C | G501N | SU TELAIO | | |
| M | G199 | | GA101 | TI002 |
| J | TS073 | | GA112 | |
| | | | | |
| | | | | |

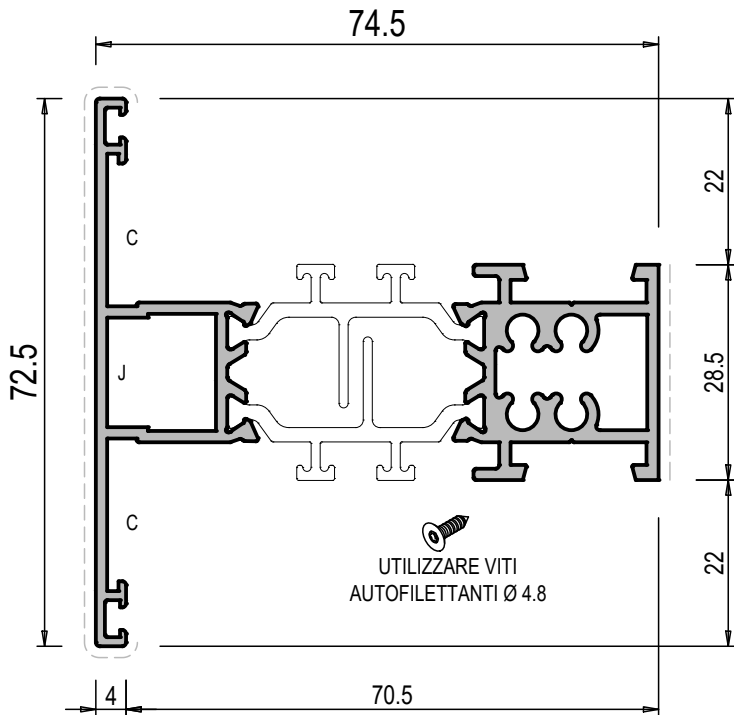

665052

| TRAVERSO PER ANTA PIANA CON VITI | | | Jx | 7.1 |
|-------------------------------------|-------|-----------|----|------|
| PESO | 1547 | | Jy | 28.1 |
| S. VISTA | 108 | | Wx | 2.0 |
| mm | | | Wy | 7.2 |
| C | G501N | SU TELAIO | | |
| J | TS073 | GA112 | | |
| | | | | |
| | | | | |

TRAVERSO ANTA PIANA

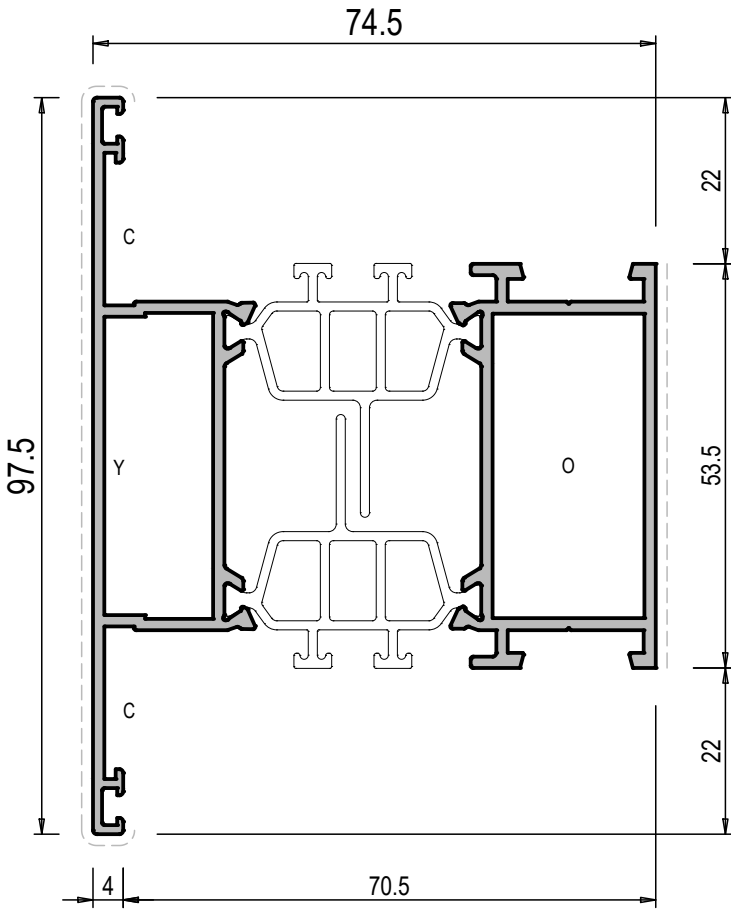

665042

| TRAVERSO PER ANTA PIANA CON CAVALLOTTI | | Jx cm ⁴ | 26.1 |
|---|-------|-----------------------|-------|
| PESO g/m | 1875 | Jy cm ⁴ | 33.9 |
| S. VISTA mm | 158 | Wx cm ³ | 5.4 |
| | | Wy cm ³ | 8.3 |
| C | G501N | | |
| O | TS083 | GA101 | T1002 |
| Y | TS074 | GA112 | |
| | | | |
| | | | |

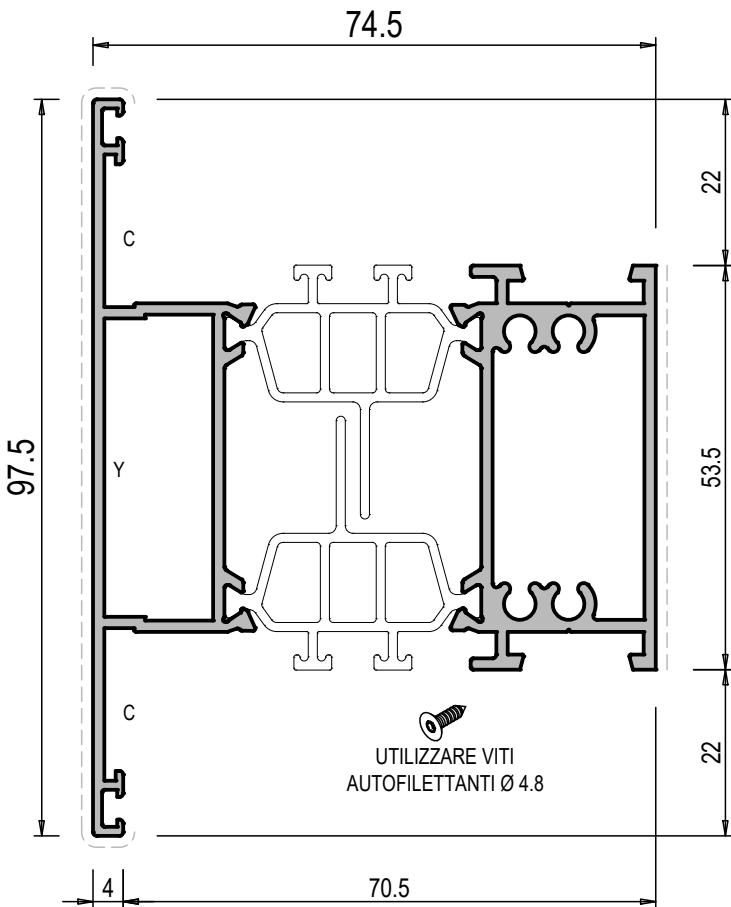

665053

| TRAVERSO PER ANTA PIANA CON VITI | | Jx cm ⁴ | 27.5 |
|-------------------------------------|-------|-----------------------|------|
| PESO g/m | 2045 | Jy cm ⁴ | 36.8 |
| S. VISTA mm | 158 | Wx cm ³ | 5.6 |
| | | Wy cm ³ | 9.4 |
| C | G501N | | |
| Y | TS074 | GA112 | |
| | | | |
| | | | |

UTILIZZARE VITI
AUTOFILETTANTI Ø 4.8

ZOCCOLO RIPORTATO ANTA PIANA

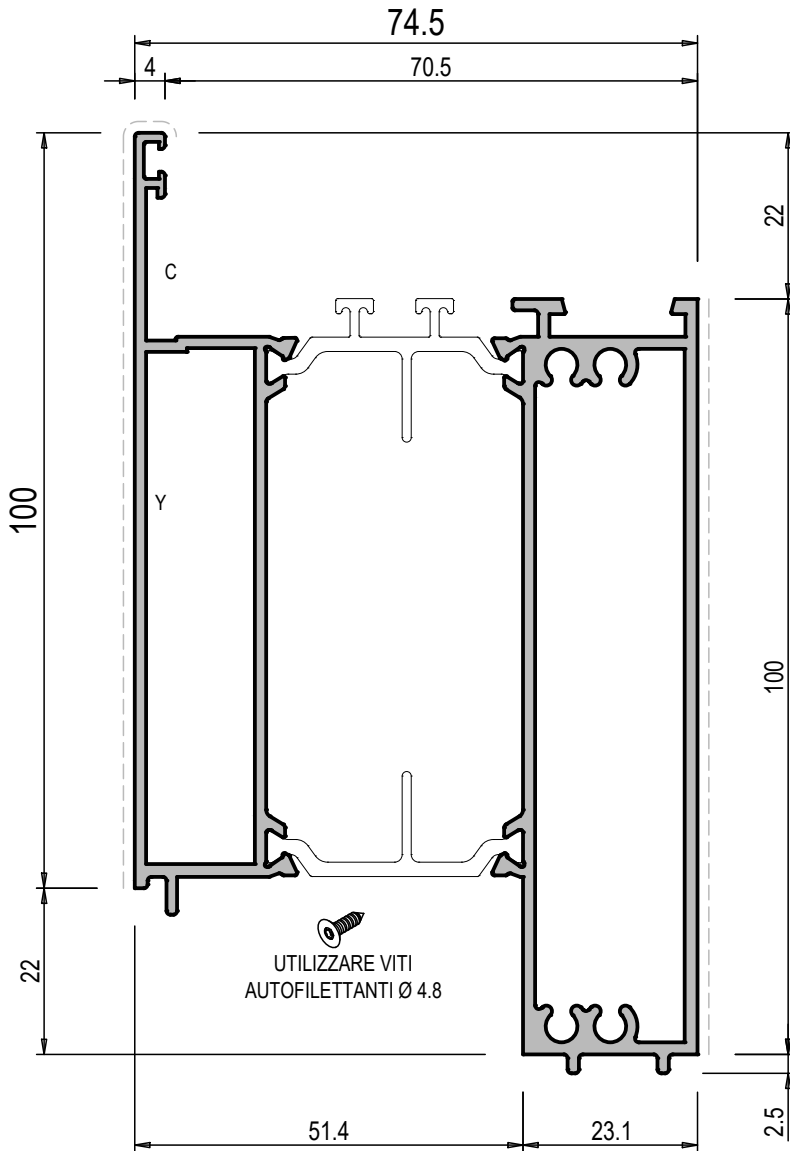

665043

| | | | |
|-----------------------------|-------|-----------------------|------|
| ZOCCOLO RIP. PER ANTA PIANA | | Jx cm ⁴ | 84.1 |
| PESO g/m | 2509 | Jy cm ⁴ | 47.5 |
| S. VISTA mm | 204 | Wx cm ³ | 13.1 |
| | | Wy cm ³ | 12.2 |
| C | G501N | | |
| Y | TS074 | GA112 | |
| | | | |
| | | | |
| | | | |
| | | | |



FASCIA PER ANTA PIANA

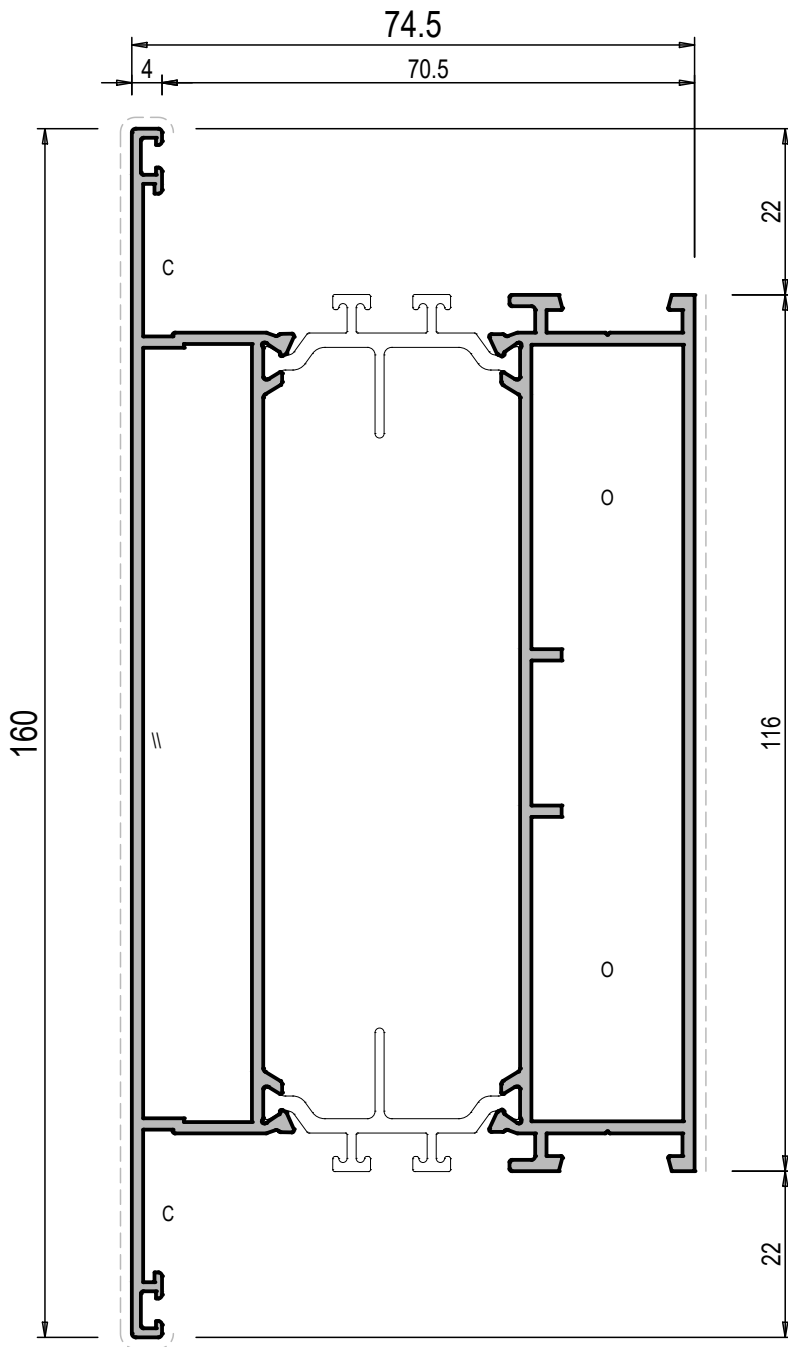

665044

| FASCIA PER ANTA PIANA CON CAVALLOTTI | | Jx cm ⁴ | 158.7 |
|---|-------|-----------------------|-------|
| PESO g/m | 3021 | Jy cm ⁴ | 56.0 |
| S. VISTA mm | 284 | Wx cm ³ | 19.8 |
| | | Wy cm ³ | 14.0 |
| C | G501N | | |
| O | TS083 | GA101 | TI002 |
| | TS088 | GA112 | |
| | | | |
| | | | |

FASCIA PER ANTA PIANA

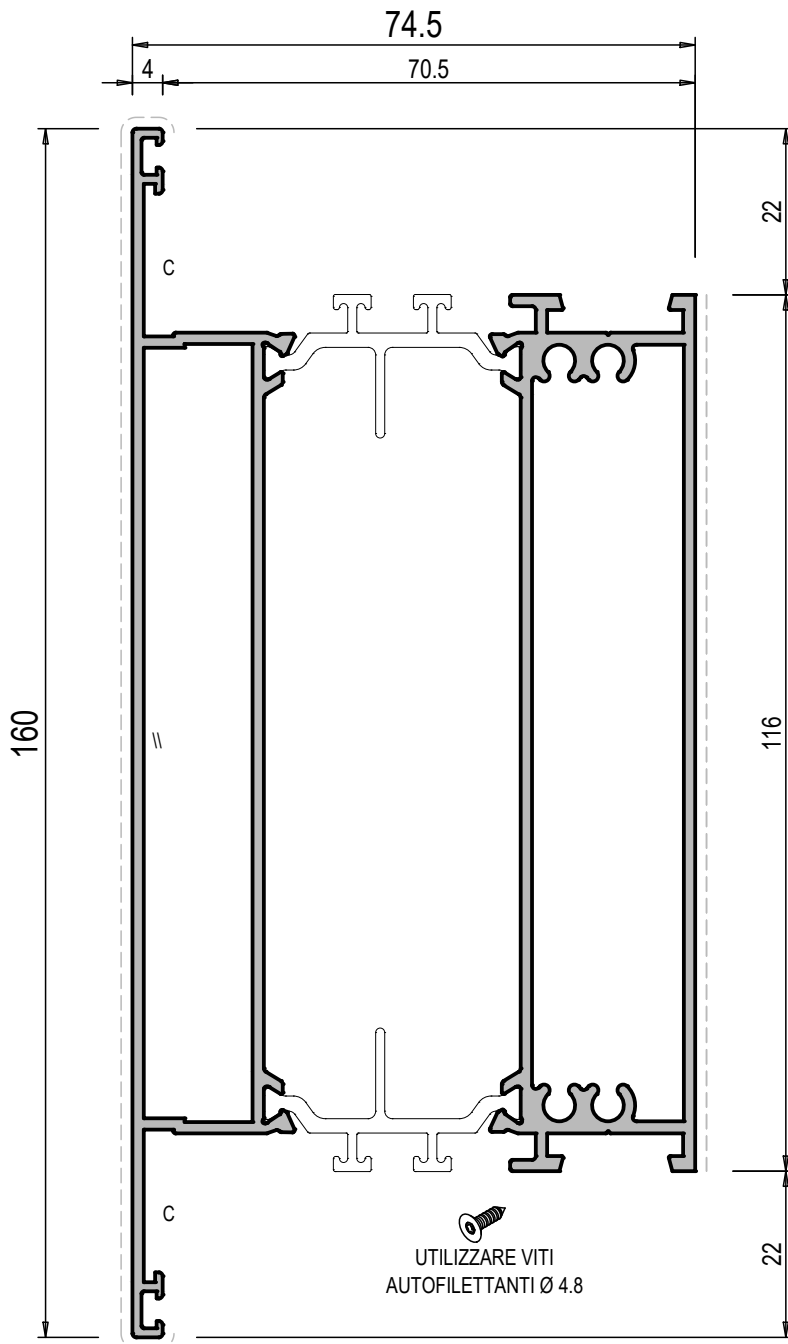

665054

| FASCIA PER ANTA PIANA CON VITI | | Jx cm ⁴ | 169.2 |
|-----------------------------------|-------|-----------------------|-------|
| PESO g/m | 3047 | Jy cm ⁴ | 58.4 |
| S. VISTA mm | 284 | Wx cm ³ | 21.2 |
| | | Wy cm ³ | 15.0 |
| C | G501N | | |
| | TS088 | | GA112 |
| | | | |
| | | | |
| | | | |
| | | | |

ZOCCOLO PER ANTA PIANA

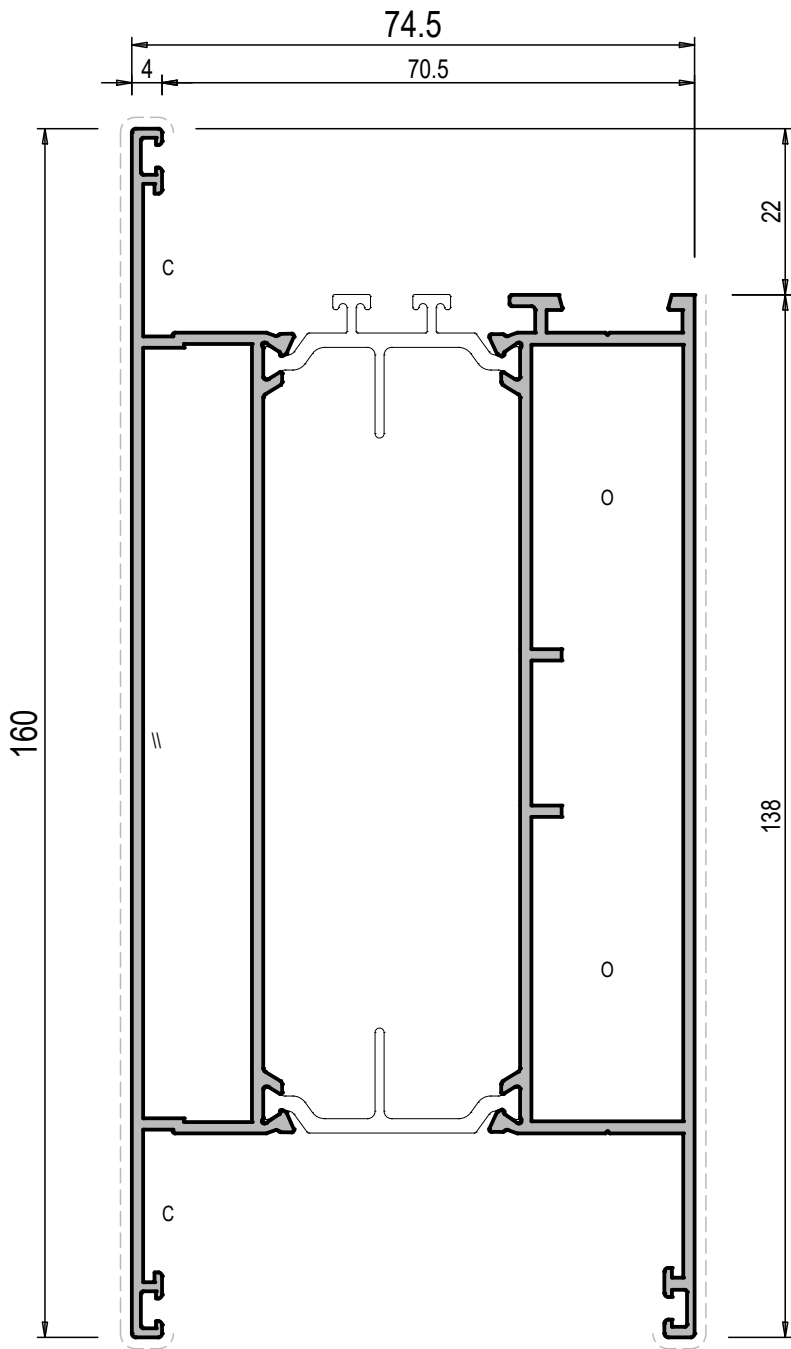

665045

| ZOCCOLO PER ANTA PIANA CON CAVALLOTTI | | Jx cm ⁴ | 162.8 |
|--|-------|-----------------------|-------|
| PESO g/m | 3026 | Jy cm ⁴ | 59.3 |
| S. VISTA mm | 310 | Wx cm ³ | 20.3 |
| | | Wy cm ³ | 15.2 |
| C | G501N | GA101 | |
| O | TS083 | | TI002 |
| | TS088 | GA112 | |
| | | | |
| | | | |

ZOCCOLO PER ANTA PIANA

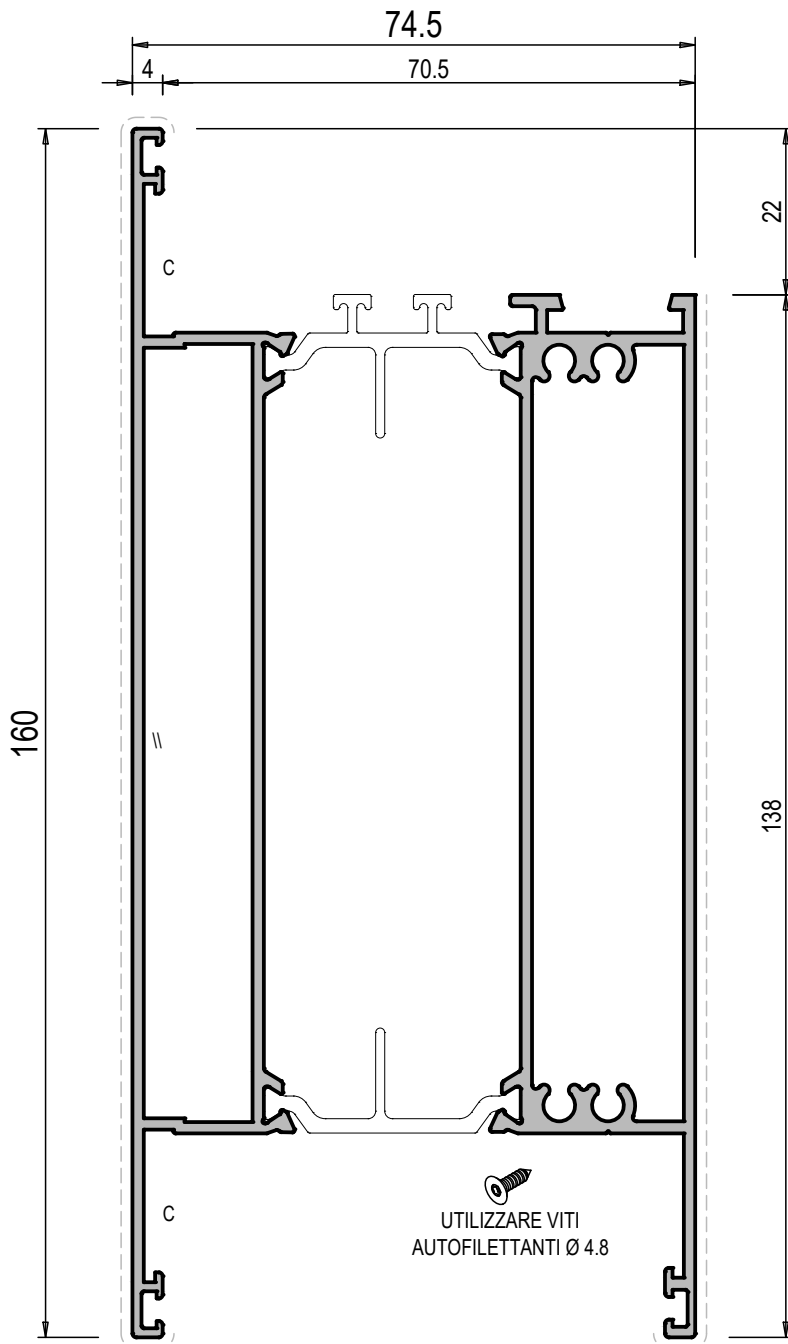

665055

| ZOCCOLO PER ANTA PIANA CON VITI | | Jx cm ⁴ | 173.5 |
|------------------------------------|-------|-----------------------|-----------------------|
| PESO g/m | 3130 | | Jy cm ⁴ |
| S. VISTA mm | 310 | Wx cm ³ | 21.6 |
| | | Wy cm ³ | 16.2 |
| C | G501N | | |
| | TS088 | | GA112 |
| | | | |
| | | | |
| | | | |
| | | | |

138



FASCIA PER ANTA PIANA

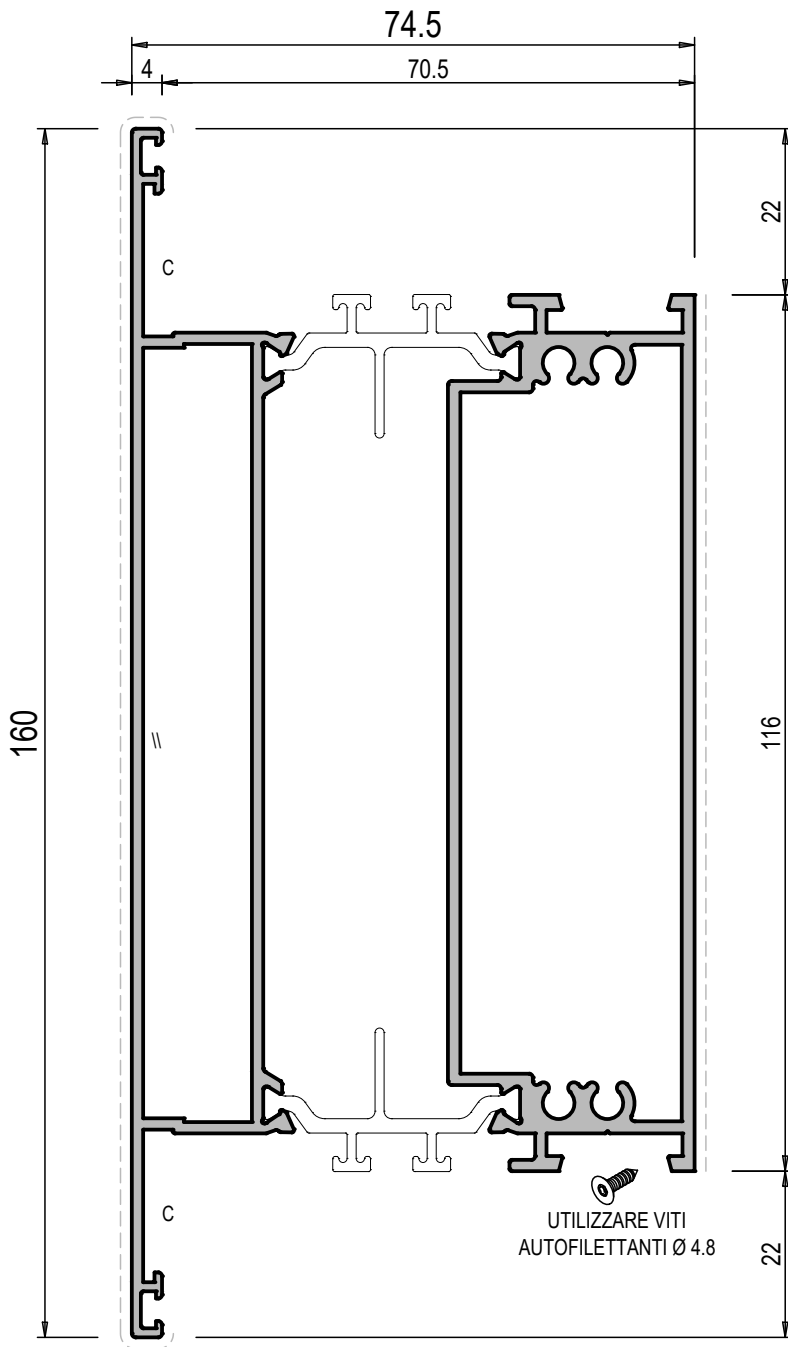

665109

| FASCIA PER ANTA PIANA PER SERRATURE | | Jx cm ⁴ | 177.8 |
|--|-------|-----------------------|-------|
| PESO g/m | 3010 | Jy cm ⁴ | 60.9 |
| S. VISTA mm | 284 | Wx cm ³ | 22.4 |
| | | Wy cm ³ | 15.4 |
| C | G501N | | |
| | TS088 | GA112 | |
| | | | |
| | | | |

PILASTRINO

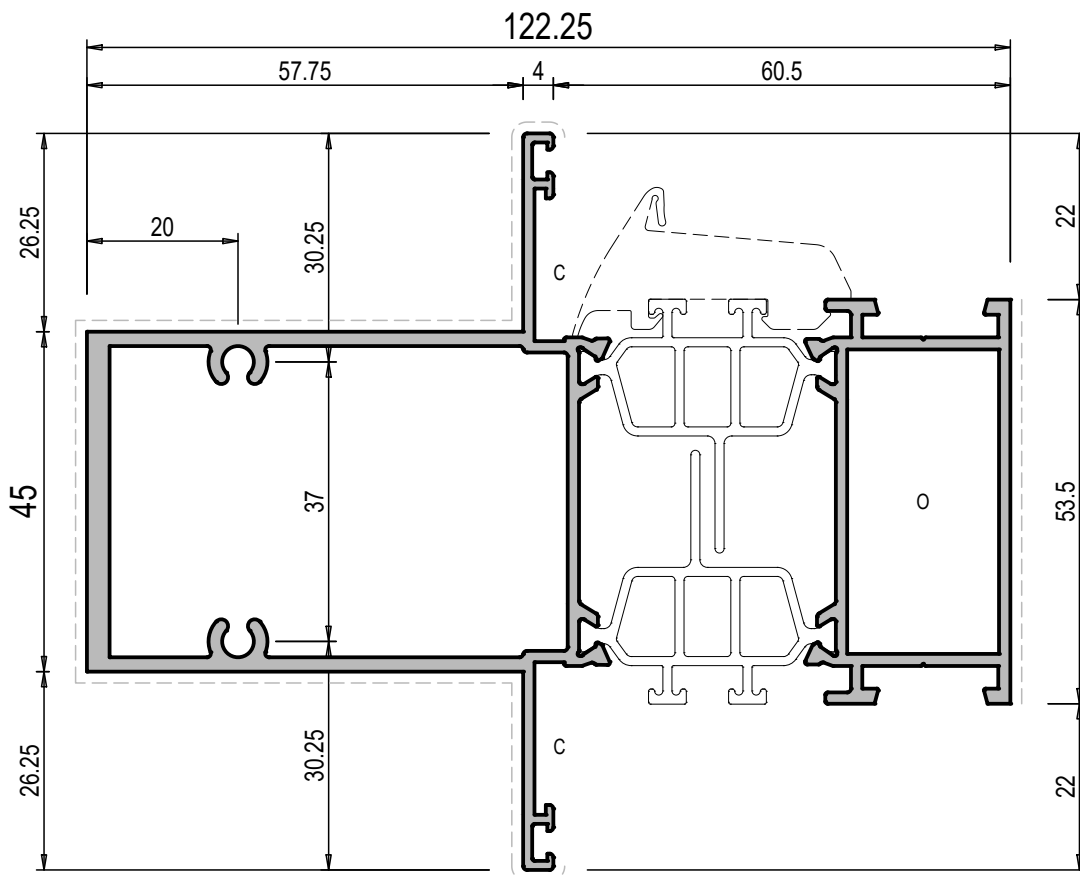

665029

| | | | | | | | | | |
|----------------|------|--|-----------------------|-------|---|-------|--|-------|-------|
| PILASTRINO | | | Jx cm ⁴ | 33.9 | O | TS083 | | GA101 | |
| PESO g/m | 2684 | | Jy cm ⁴ | 110.6 | C | G501N | | | TI002 |
| S. VISTA mm | 274 | | Wx cm ³ | 7.0 | | | | | |
| | | | Wy cm ³ | 17.5 | | | | | |

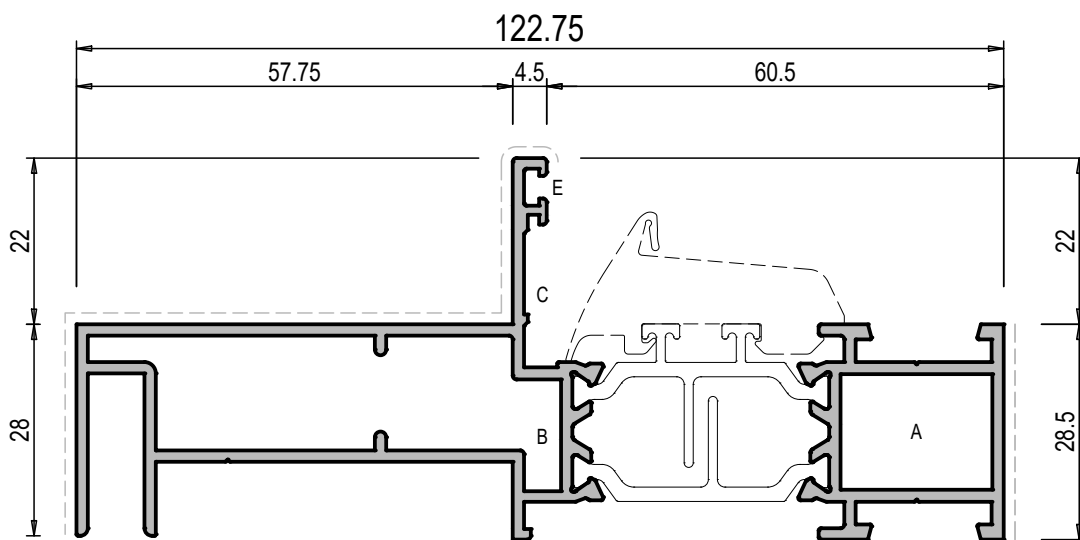

665030

SCARICO ACQUA NON ESEGUIBILE CON PUNZONATRICI.

| | | | | | | | | | |
|----------------|------|--|-----------------------|------|---|-------|-------|-------|-------|
| SEMIPILASTRINO | | | Jx cm ⁴ | 5.9 | A | TS078 | TS077 | GA101 | TI001 |
| PESO g/m | 1838 | | Jy cm ⁴ | 72.4 | B | TS079 | | GA036 | TI003 |
| S. VISTA mm | 140 | | Wx cm ³ | 1.8 | C | G501N | | | |
| | | | Wy cm ³ | 10.8 | E | G112 | | | |

GIUNZIONE 90° E CIELINO MONOBLOCCO

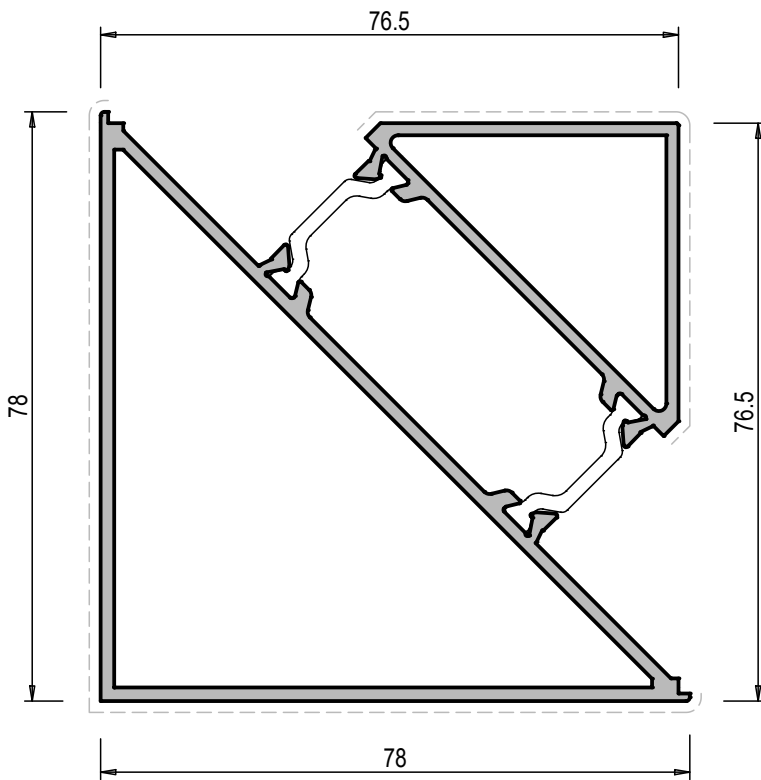

61727

| GIUNZIONE 90° | | Jx | cm ⁴ | 38.9 | |
|---------------|-----|------|-----------------|-----------------|------|
| PESO | g/m | 2129 | Jy | cm ⁴ | 38.9 |
| S. VISTA | mm | 241 | Wx | cm ³ | 9.7 |
| | | | Wy | cm ³ | 9.7 |

| | | | | |
|--|--|--|--|--|
| | | | | |
| | | | | |
| | | | | |
| | | | | |

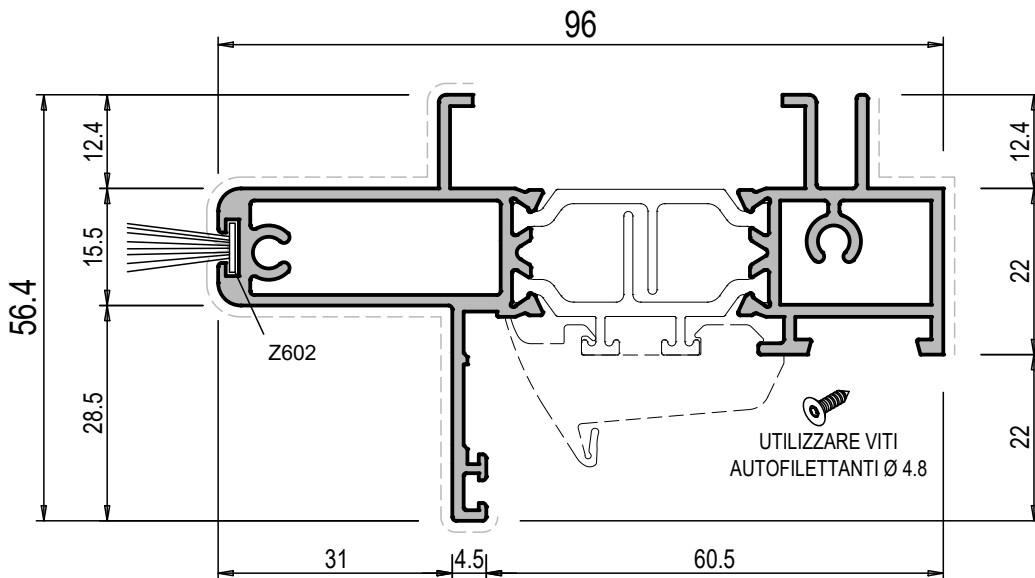

665031

| CIELINO MONOBLOCCO | | y | Jx | cm ⁴ | 5.5 | | |
|--------------------|-----|------|--|-----------------|------|--|--|
| PESO | g/m | 1652 | Jy <td>cm⁴</td> <td>38.2</td> <td></td> <td></td> | cm ⁴ | 38.2 | | |
| S. VISTA | mm | 170 | Wx <td>cm³</td> <td>1.6</td> <td></td> <td></td> | cm ³ | 1.6 | | |
| | | | Wy <td>cm³</td> <td>7.4</td> <td></td> <td></td> | cm ³ | 7.4 | | |

Profilati Scala 1:1



SPALLA MONOBLOCCO

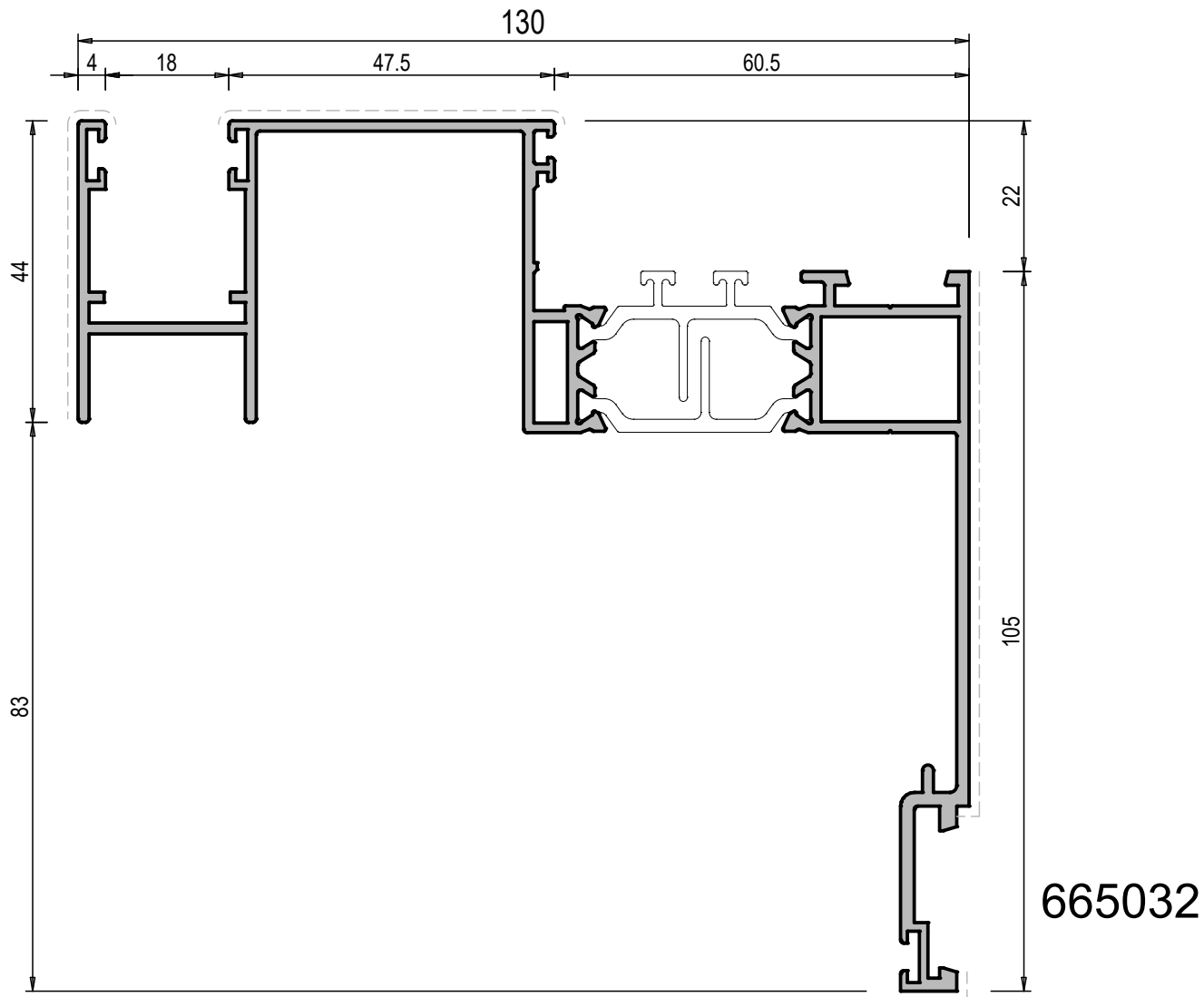

| SPALLA MONOBLOCCO | | | Jx | 62.8 | | |
|-------------------|------|--|----|-------|--|--|
| PESO | 2359 | | Jy | 119.6 | | |
| S. VISTA | 174 | | Wx | 7.3 | | |
| mm | | | Wy | 14.8 | | |

1234

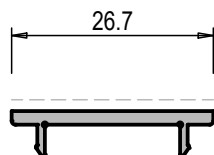

| COMPLEMENTARE MONOB. | | | Jx | |
|----------------------|-----|--|----|--|
| PESO | 151 | | Jy | |
| S. VISTA | 27 | | Wx | |
| mm | | | Wy | |

| | | | | |
|--|--|--|--|--|
| | | | | |
| | | | | |
| | | | | |
| | | | | |
| | | | | |

CASSONETTO

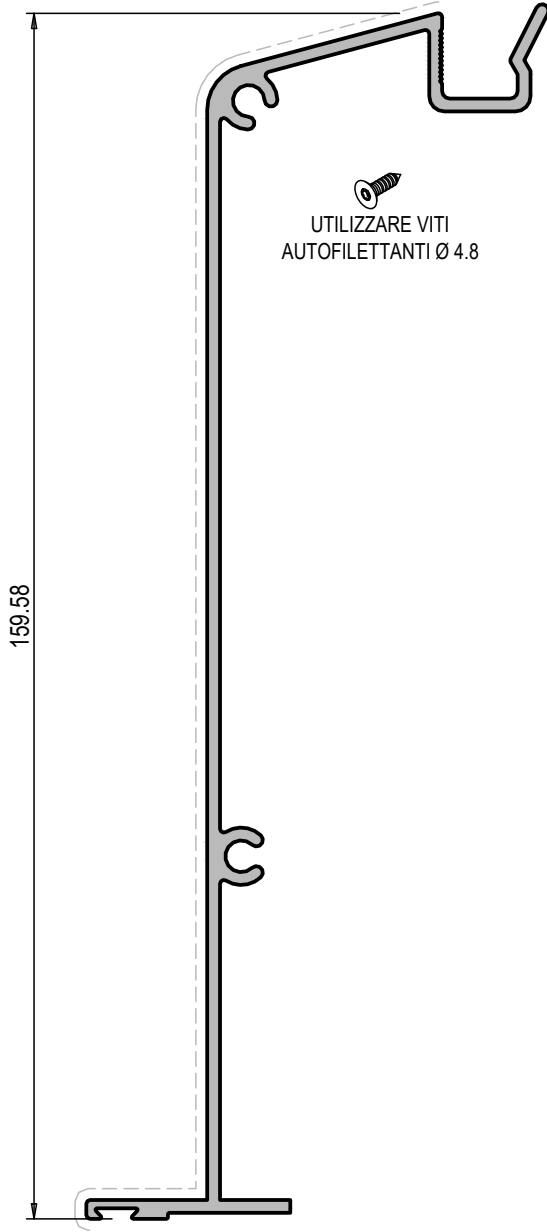

UTILIZZARE VITI
AUTOFILETTANTI Ø 4.8

159.58

1185

| | | | | | |
|----------------|------|--|----|-----------------|--|
| CASSONETTO "A" | | | Jx | cm ⁴ | |
| PESO | 1250 | | Jy | cm ⁴ | |
| S. VISTA | 196 | | Wx | cm ³ | |
| mm | | | Wy | cm ³ | |

| | | | | |
|--|--|--|--|--|
| | | | | |
| | | | | |
| | | | | |
| | | | | |

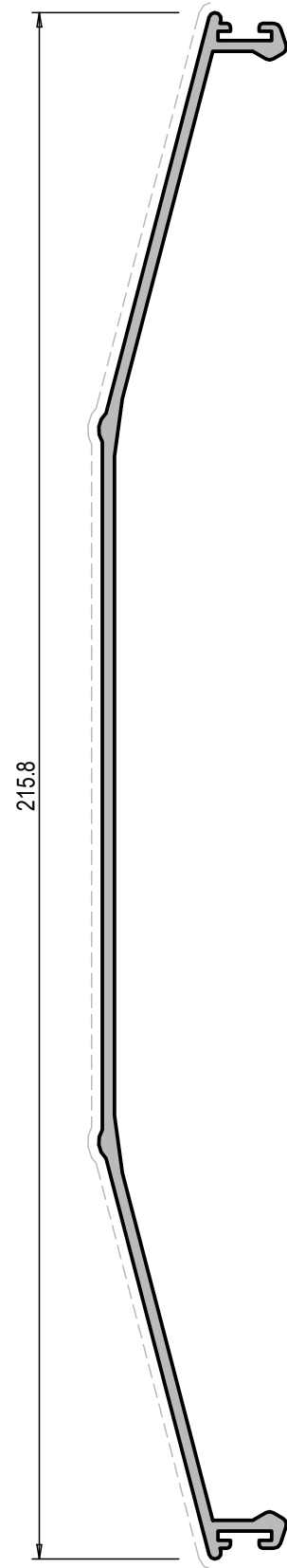

215.8

1184

| | | | | | |
|----------------|------|--|----|-----------------|--|
| CASSONETTO "B" | | | Jx | cm ⁴ | |
| PESO | 1165 | | Jy | cm ⁴ | |
| S. VISTA | 220 | | Wx | cm ³ | |
| mm | | | Wy | cm ³ | |

TELAIO CAPANNONE

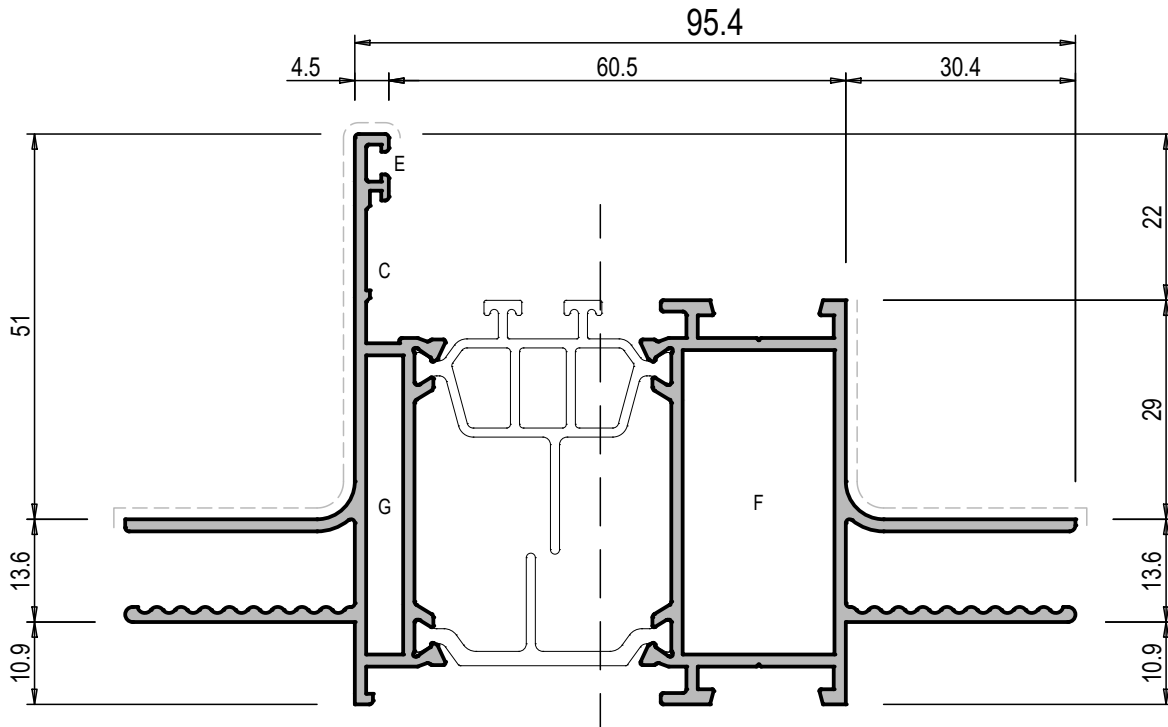

665035

| TELAIO CAPANNONI | | | | Jx | 22.1 |
|------------------|-------|---|---|-------|-------|
| PESO | 2173 | S | X | Jy | 56.7 |
| S. VISTA | 142 | | | Wx | 4.6 |
| | | | | Wy | 8.6 |
| C | G501N | | | GA101 | TI001 |
| | | | | GA036 | TI003 |
| E | G112 | | | | |
| F | TS080 | | | | |
| G | TS081 | | | | |

Profilati Scala 1:1



TELAIO CAPANNONE

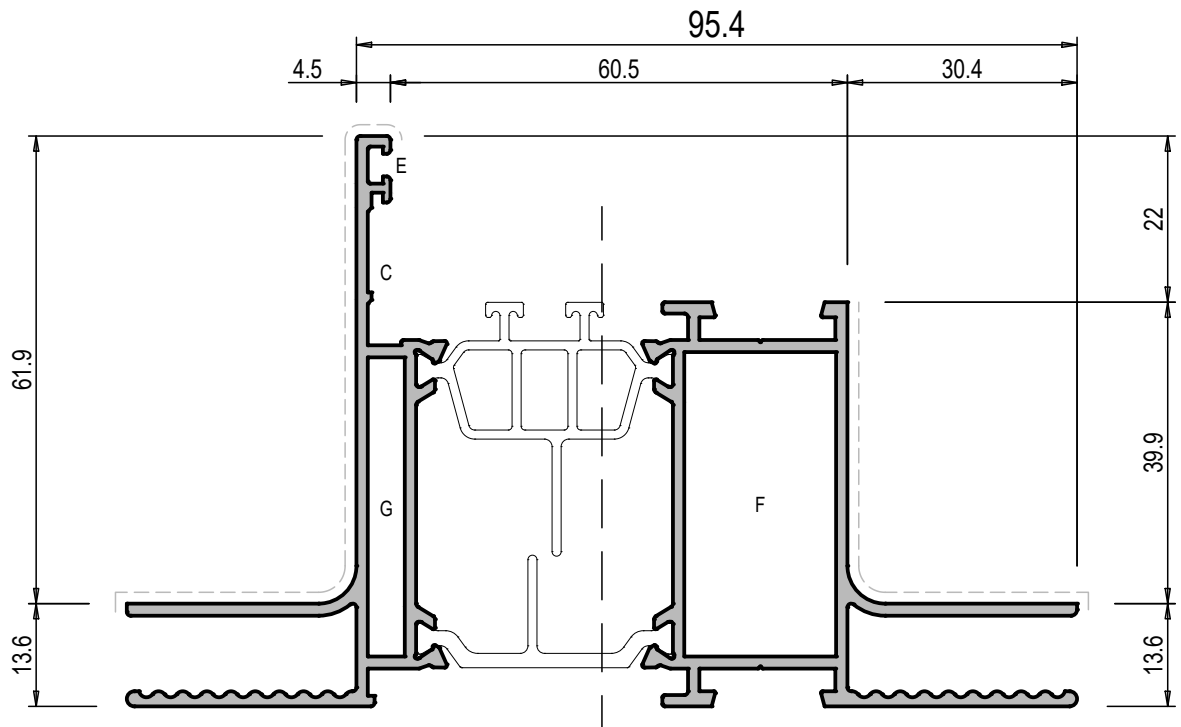

665092

| TELAIO CAPANNONI | | Jx | 27.0 |
|------------------|-------|-------|-------|
| PESO | 2173 | Jy | 57.1 |
| S. VISTA | 164 | Wx | 5.4 |
| g/m | | Wy | 8.6 |
| mm | | | |
| C | G501N | GA101 | T1001 |
| E | G112 | GA036 | T1003 |
| F | TS080 | | |
| G | TS081 | | |

TELAIO CAPANNONE

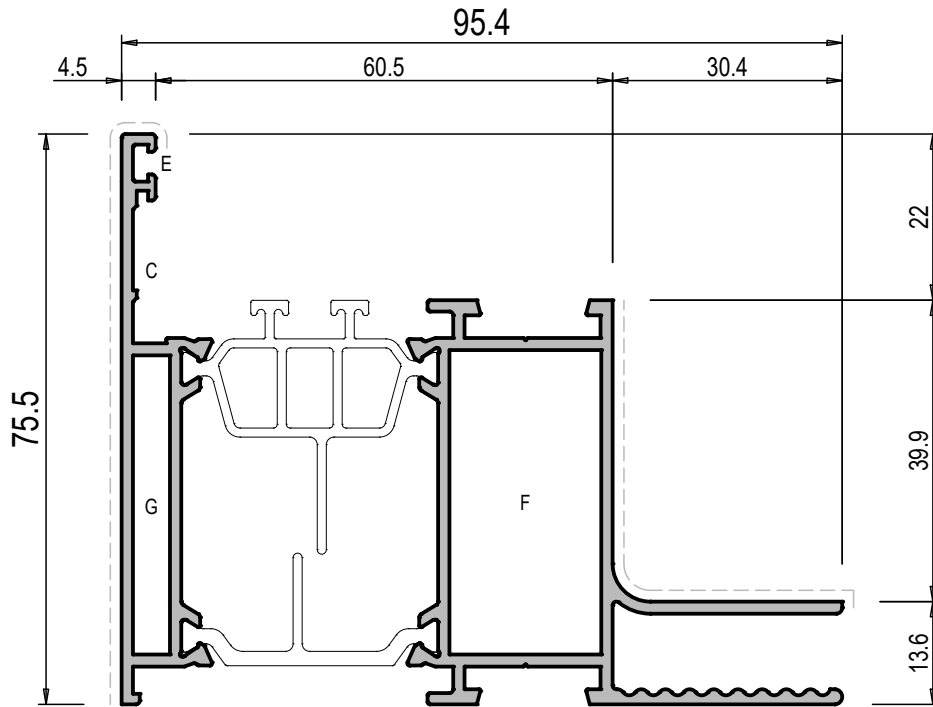

665124

| TELAIO L CAPANNONI | | Jx | 29.4 |
|--------------------|------|----|------|
| PESO | 1904 | Jy | 44.8 |
| S. VISTA | 151 | Wx | 5.6 |
| | | Wy | 7 |

| | | | | | |
|---|-------|--|-------|--|-------|
| C | G501N | | | | |
| E | G112 | | | | |
| F | TS080 | | GA101 | | T1001 |
| G | TS081 | | | | T1003 |

Profilati Scala 1:1



TELAIO CAPANNONE

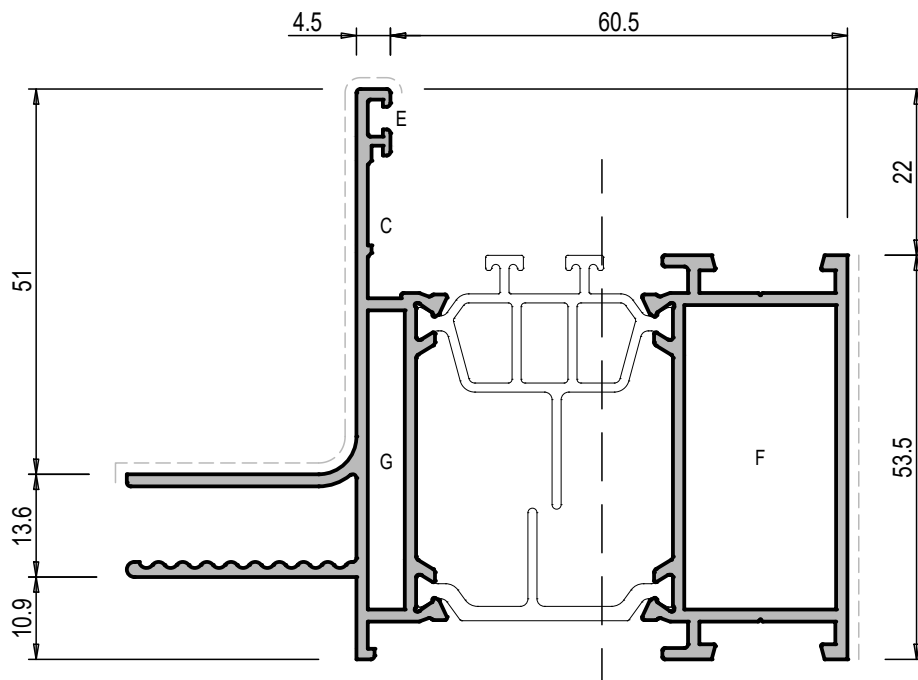

665135

| TELAIO CAPANNONI | | Jx | 21 |
|------------------|-------|-------|-------|
| PESO | 1904 | Jy | 36.4 |
| S. VISTA | 142 | Wx | 4.2 |
| | | Wy | 7 |
| C | G501N | | |
| E | G112 | | |
| F | TS080 | | |
| G | TS081 | | |
| | | GA101 | T1001 |
| | | GA036 | T1003 |
| | | | |

TELAIO CAPANNONE

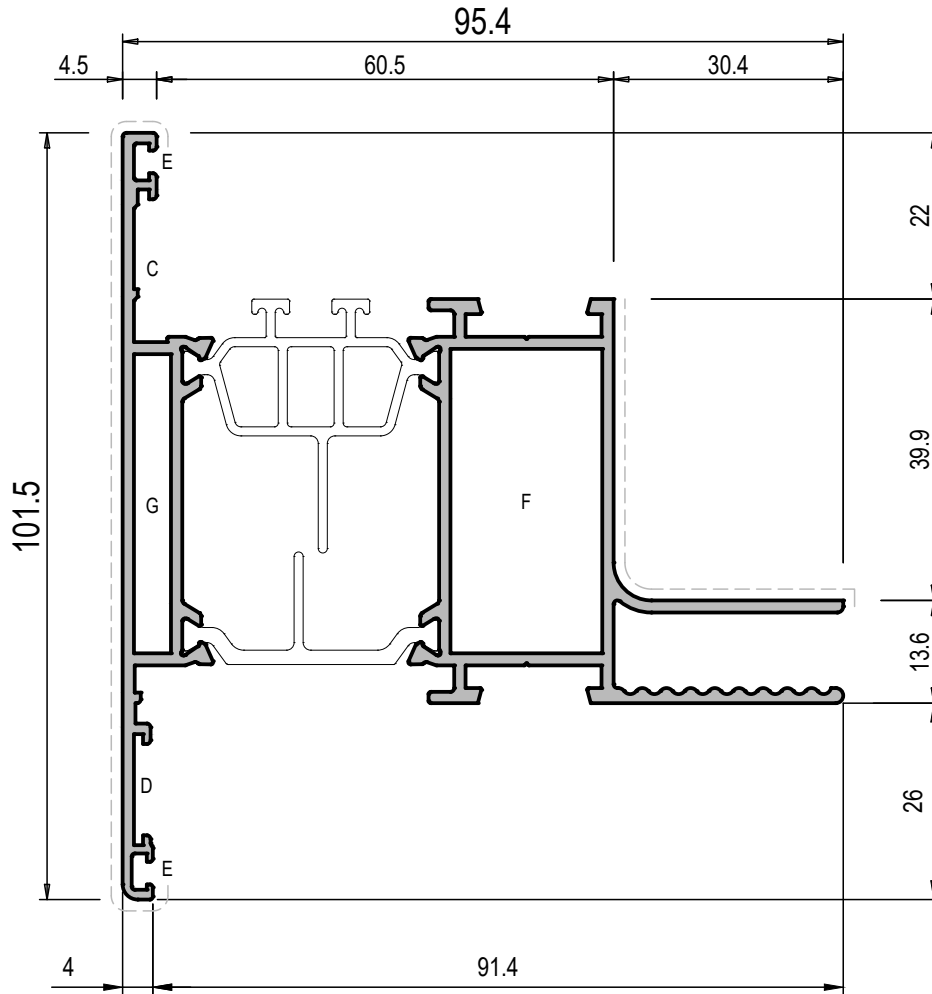

665112

| TELAIO T CAPANNONI | | Jx | 29.4 |
|--------------------|------|----|------|
| PESO | 2039 | Jy | 44.8 |
| S. VISTA | 181 | Wx | 5.6 |
| | | Wy | 7 |

| | | | | | |
|---|-------|--|--|-------|-------|
| C | G501N | | | | |
| D | G269 | | | | |
| E | G112 | | | | |
| F | TS080 | | | GA101 | TI001 |
| G | TS081 | | | | TI003 |

Profilati Scala 1:1



TELAIO CAPANNONE

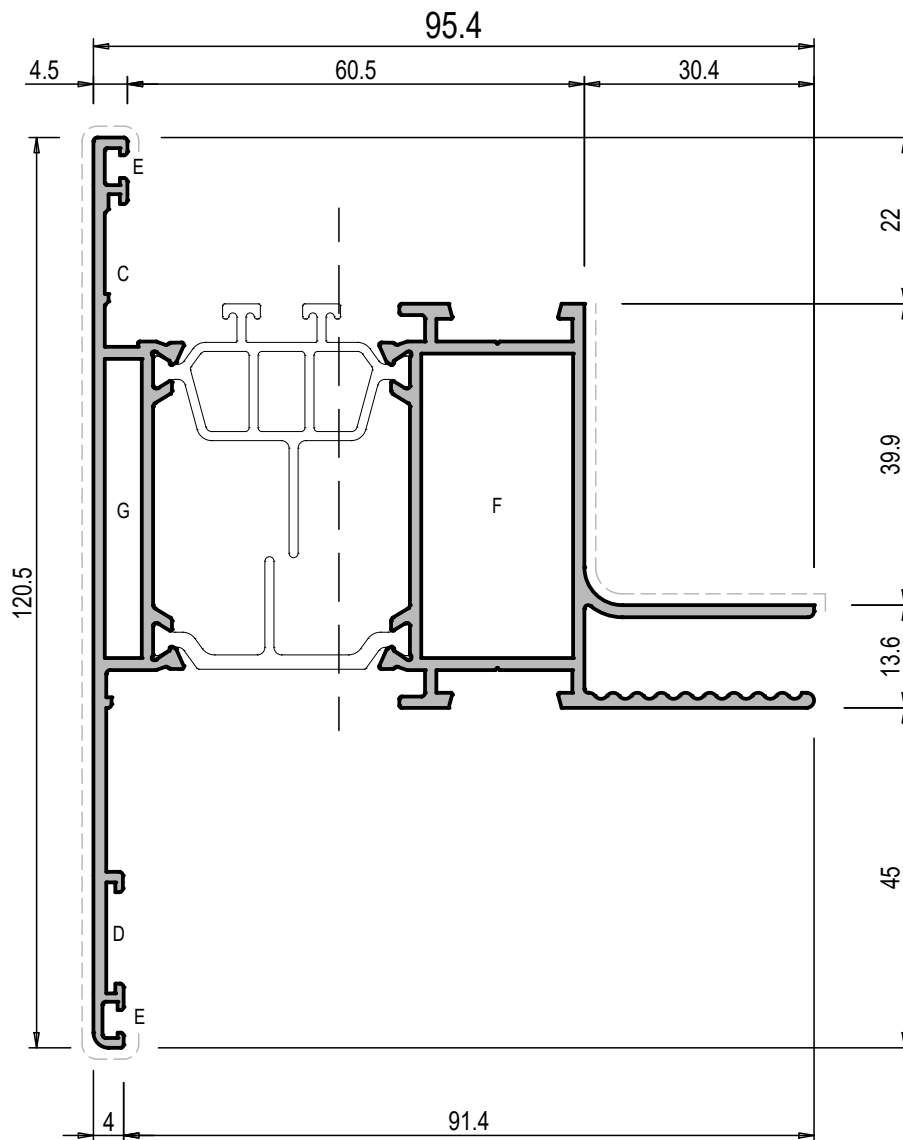

665134

| TELAIO CAPANNONI T | | Jx | 38.5 |
|--------------------|-------|-------|-------|
| PESO | 2137 | Jy | 47.6 |
| S. VISTA | 200 | Wx | 5.6 |
| g/m | | Wy | 7.7 |
| mm | | | |
| C | G501N | GA101 | T1001 |
| D | G269 | GA036 | T1003 |
| E | G112 | | |
| F | TS080 | | |
| G | TS081 | | |

IMBOTTE

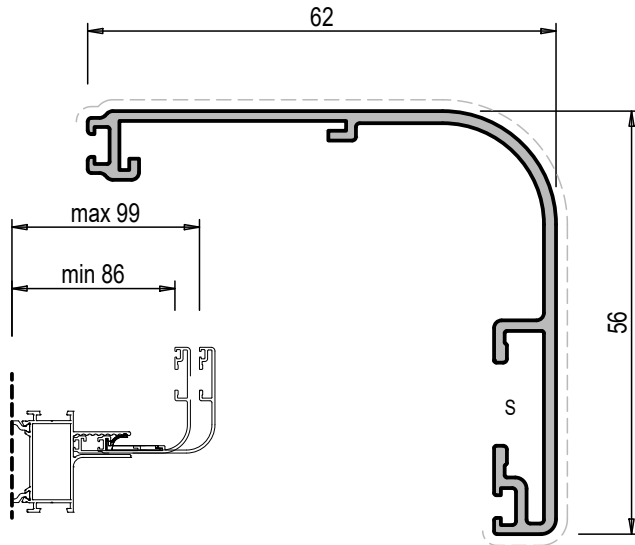

40291

| IMBOTTE "A" | | Jx | cm ⁴ |
|-------------|--------|----|-----------------|
| PESO | 641 | Jy | cm ⁴ |
| S. VISTA | 120 | Wx | cm ³ |
| | | Wy | cm ³ |
| S | TA1000 | | |
| | | | |
| | | | |
| | | | |
| | | | |
| | | | |

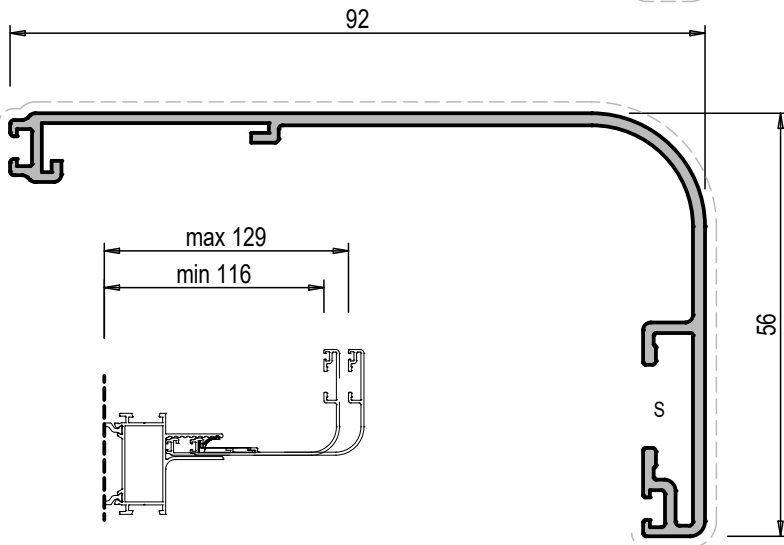

40292

| IMBOTTE "B" | | Jx | cm ⁴ |
|-------------|--------|----|-----------------|
| PESO | 770 | Jy | cm ⁴ |
| S. VISTA | 150 | Wx | cm ³ |
| | | Wy | cm ³ |
| S | TA1000 | | |
| | | | |
| | | | |
| | | | |
| | | | |
| | | | |

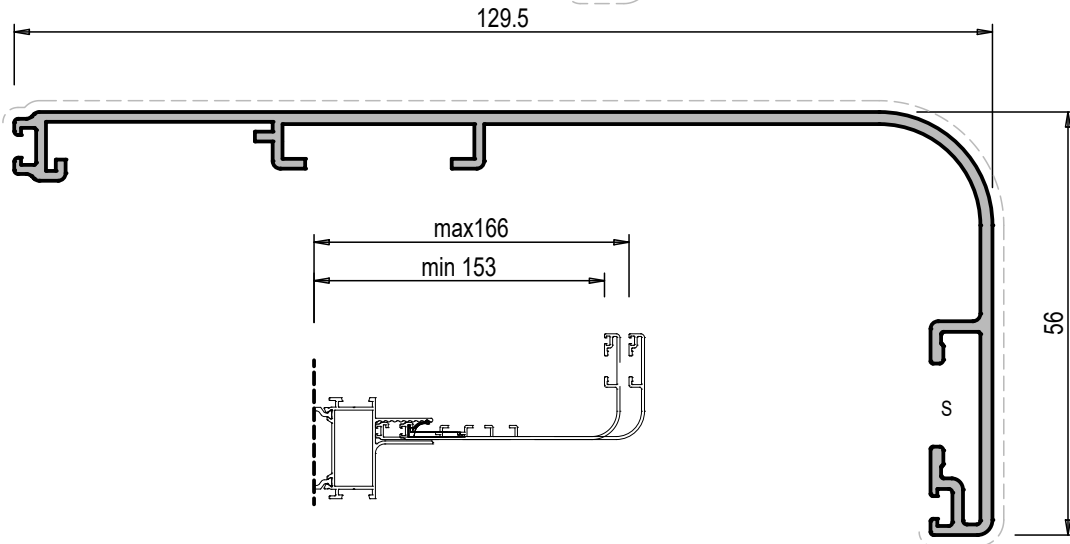

40293

| IMBOTTE "C" | | Jx | cm ⁴ |
|-------------|--------|----|-----------------|
| PESO | 985 | Jy | cm ⁴ |
| S. VISTA | 188 | Wx | cm ³ |
| | | Wy | cm ³ |
| S | TA1000 | | |
| | | | |
| | | | |
| | | | |
| | | | |

Profilati Scala 1:1



GIUNZIONE CON PLATHINA 78S

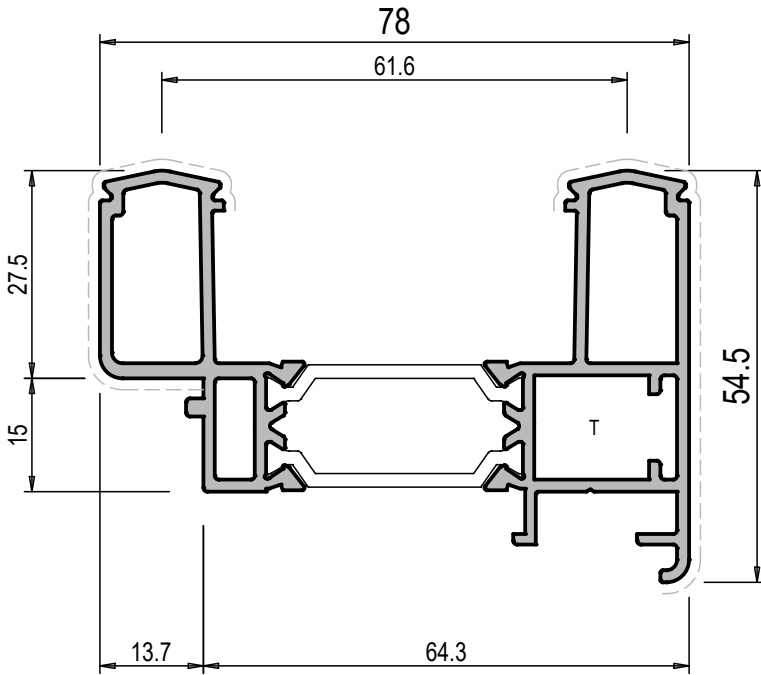

665036

| GIUNZIONE PLATHINA 78S | | | Jx | 8.4 |
|------------------------|-------|--|-------|-------|
| PESO | 1598 | | Jy | 31.1 |
| S. VISTA | 132 | | Wx | 3.1 |
| g/m | | | Wy | 7.3 |
| mm | | | | |
| T | TS001 | | GA101 | T1001 |
| | | | GA036 | T1003 |
| | | | | |
| | | | | |

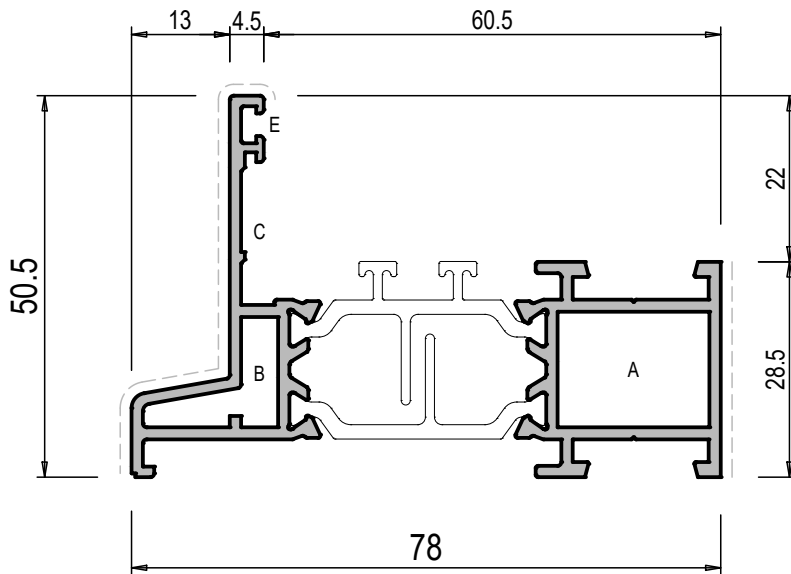

665037

| GIUNZIONE PLATHINA 78S - 78AS | | | Jx | 4.8 |
|-------------------------------|-------|-------|-------|-------|
| PESO | 1291 | | Jy | 21.0 |
| S. VISTA | 93 | | Wx | 1.4 |
| g/m | | | Wy | 5.4 |
| mm | | | | |
| A | TS078 | TS077 | GA101 | T1001 |
| B | TS079 | | GA036 | T1003 |
| C | G501N | | | |
| E | G112 | | | |
| | | | | |

INSERIMENTO IN FACCIATA E GIUNZIONE TELAI

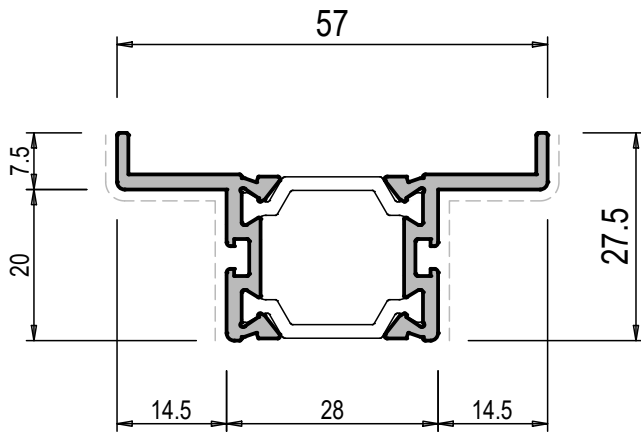

665080

| | | | | | |
|-----------------------------|-------|--|-------|-----------------|--|
| GIUNZIONE TELAI IN FACCIATA | | | Jx | cm ⁴ | |
| PESO | 748 | | Jy | cm ⁴ | |
| S. VISTA | 84 | | Wx | cm ³ | |
| | | | Wy | cm ³ | |
| T | TS001 | | GA101 | | |
| | | | GA036 | | |
| | | | | | |
| | | | | | |

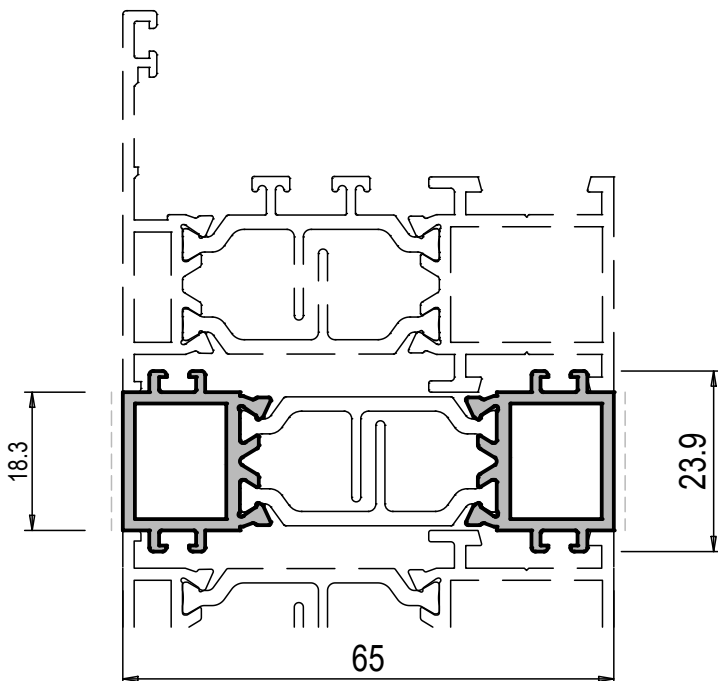

665086

| | | | | | |
|----------------------|-------|-------|----|-----------------|------|
| GIUNZIONE TELI A "L" | | | Jx | cm ⁴ | 1.5 |
| PESO | 948 | | Jy | cm ⁴ | 12.3 |
| S. VISTA | 37 | | Wx | cm ³ | 1.1 |
| | | | Wy | cm ³ | 3.7 |
| A | TS078 | TS077 | | | |
| B | TS079 | | | | |
| C | G501N | | | | |
| E | G112 | | | | |

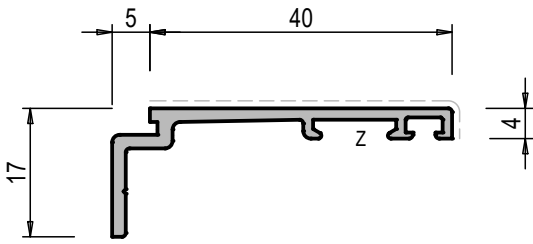

665276

| | | | | |
|---------------|-----|-----|-----------------|-----------------|
| COPRIFILO "A" | | Jx | cm ⁴ | |
| PESO | g/m | 306 | Jy | cm ⁴ |
| S. VISTA | mm | 44 | Wx | cm ³ |
| | | | Wy | cm ³ |

| | | | | | | | | | |
|---|---|------|--|--|--|--|--|--|--|
| Z | ✓ | G255 | | | | | | | |
| | | | | | | | | | |
| | | | | | | | | | |
| | | | | | | | | | |
| | | | | | | | | | |
| | | | | | | | | | |

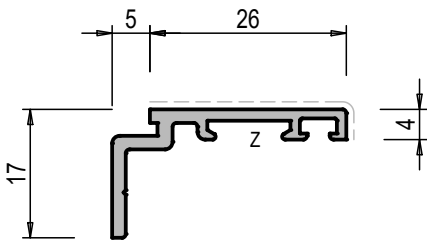

665277

| | | | | |
|---------------|-----|-----|-----------------|-----------------|
| COPRIFILO "B" | | Jx | cm ⁴ | |
| PESO | g/m | 244 | Jy | cm ⁴ |
| S. VISTA | mm | 30 | Wx | cm ³ |
| | | | Wy | cm ³ |

| | | | | | | | | | |
|---|---|------|--|--|--|--|--|--|--|
| Z | ✓ | G255 | | | | | | | |
| | | | | | | | | | |
| | | | | | | | | | |
| | | | | | | | | | |
| | | | | | | | | | |
| | | | | | | | | | |

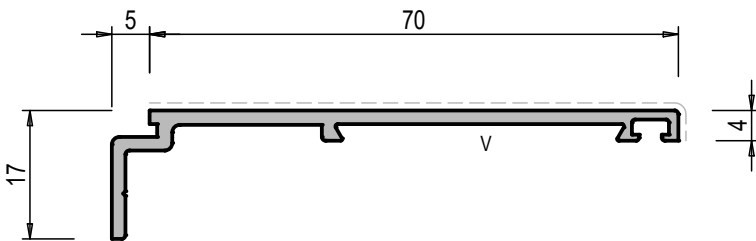

665278

| | | | | |
|---------------|-----|-----|-----------------|-----------------|
| COPRIFILO "C" | | Jx | cm ⁴ | |
| PESO | g/m | 475 | Jy | cm ⁴ |
| S. VISTA | mm | 74 | Wx | cm ³ |
| | | | Wy | cm ³ |

| | | | | | | | | | |
|---|---|------|--|--|--|--|--|--|--|
| V | ✓ | G220 | | | | | | | |
| | | | | | | | | | |
| | | | | | | | | | |
| | | | | | | | | | |
| | | | | | | | | | |
| | | | | | | | | | |



COPRIFILI

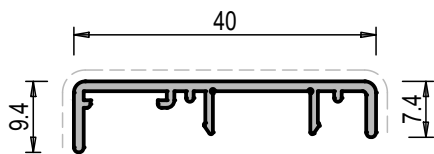

40320

| | | | | | |
|------------------------|-----|--|----|-----------------|--|
| COPRIFILO A SCATTO "A" | | | Jx | cm ⁴ | |
| PESO | 233 | | Jy | cm ⁴ | |
| S. VISTA | 57 | | Wx | cm ³ | |
| | | | Wy | cm ³ | |
| | | | | | |
| | | | | | |
| | | | | | |
| | | | | | |

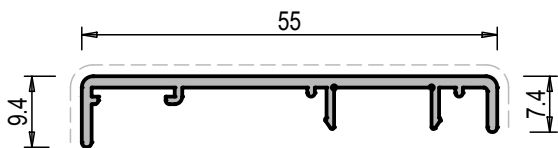

40321

| | | | | | |
|------------------------|-----|--|----|-----------------|--|
| COPRIFILO A SCATTO "A" | | | Jx | cm ⁴ | |
| PESO | 312 | | Jy | cm ⁴ | |
| S. VISTA | 72 | | Wx | cm ³ | |
| | | | Wy | cm ³ | |
| | | | | | |
| | | | | | |
| | | | | | |
| | | | | | |

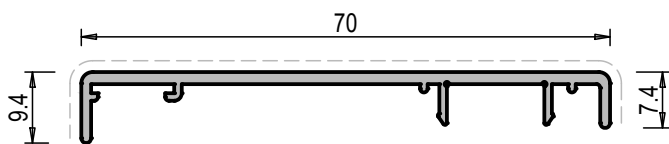

40322

| | | | | | |
|------------------------|-----|--|----|-----------------|--|
| COPRIFILO A SCATTO "A" | | | Jx | cm ⁴ | |
| PESO | 390 | | Jy | cm ⁴ | |
| S. VISTA | 87 | | Wx | cm ³ | |
| | | | Wy | cm ³ | |
| | | | | | |
| | | | | | |
| | | | | | |
| | | | | | |

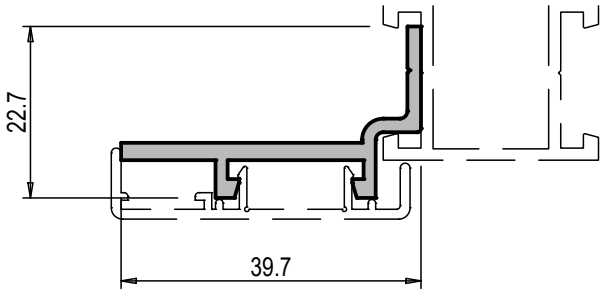

40319

| | | | |
|-----------------------------|-----|-----------------------|--|
| BASE PER COPRIFILI A SCATTO | | Jx cm ⁴ | |
| PESO g/m | 370 | Jy cm ⁴ | |
| S. VISTA mm | -- | Wx cm ³ | |
| | | Wy cm ³ | |

| | | | | |
|--|--|--|--|--|
| | | | | |
| | | | | |
| | | | | |
| | | | | |

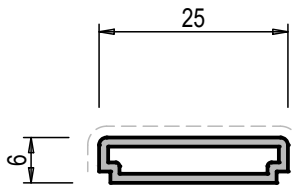

40272

| | | | |
|-------------------------|-----|-----------------------|--|
| INGLESINA "A" VERTICALE | | Jx cm ⁴ | |
| PESO g/m | 184 | Jy cm ⁴ | |
| S. VISTA mm | 34 | Wx cm ³ | |
| | | Wy cm ³ | |

| | | | | |
|--|--|--|--|--|
| | | | | |
| | | | | |
| | | | | |
| | | | | |

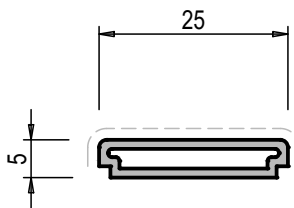

40273

| | | | |
|---------------------------|-----|-----------------------|--|
| INGLESINA "B" ORIZZONTALE | | Jx cm ⁴ | |
| PESO g/m | 178 | Jy cm ⁴ | |
| S. VISTA mm | 33 | Wx cm ³ | |
| | | Wy cm ³ | |

| | | | | |
|--|--|--|--|--|
| | | | | |
| | | | | |
| | | | | |
| | | | | |

COMPLEMENTARI

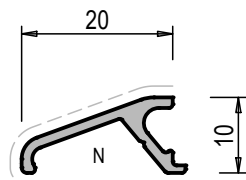

40269

| GOCCIOLATOIO UNIVERSALE | | Jx | cm ⁴ |
|-------------------------|-----|----|-----------------|
| PESO g/m | 141 | Jy | cm ⁴ |
| S. VISTA mm | 23 | Wx | cm ³ |
| | | Wy | cm ³ |

| N | GT118 | CF. TAPPI | |
|---|-------|-----------|--|
| | | | |
| | | | |
| | | | |
| | | | |
| | | | |
| | | | |
| | | | |

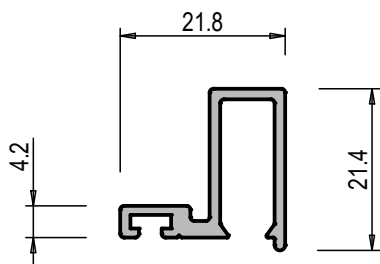

665282

| GOCCIOLATOIO PER PROFILATI DOPPIA BATTUTA | | Jx | cm ⁴ |
|---|-----|----|-----------------|
| PESO g/m | 272 | Jy | cm ⁴ |
| S. VISTA mm | 26 | Wx | cm ³ |
| | | Wy | cm ³ |

| N | GT118 | CF. TAPPI | |
|---|-------|-----------|--|
| | | | |
| | | | |
| | | | |
| | | | |
| | | | |
| | | | |
| | | | |

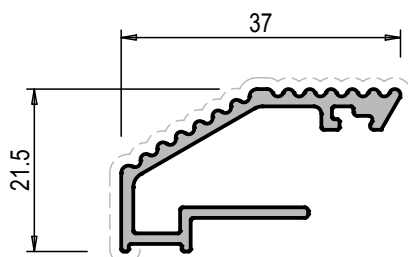

665250

| COMPL. SOGLIA RIBASSATA | | Jx | cm ⁴ |
|-------------------------|-----|----|-----------------|
| PESO g/m | 377 | Jy | cm ⁴ |
| S. VISTA mm | 63 | Wx | cm ³ |
| | | Wy | cm ³ |

| N | GT118 | CF. TAPPI | |
|---|-------|-----------|--|
| | | | |
| | | | |
| | | | |
| | | | |
| | | | |
| | | | |
| | | | |

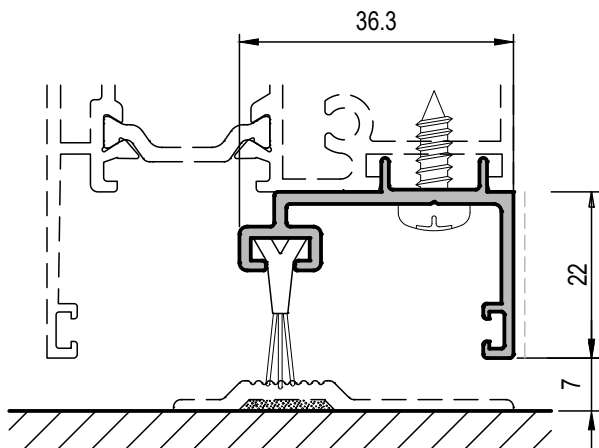

40282

| | | | | |
|------------|-----|----|-----------------|--|
| SOTTOPORTA | | Jx | cm ⁴ | |
| PESO | 375 | Jy | cm ⁴ | |
| g/m | | Wx | cm ³ | |
| S. VISTA | 22 | Wy | cm ³ | |
| mm | | | | |
| | | | | |
| | | | | |
| | | | | |
| | | | | |
| | | | | |
| | | | | |
| | | | | |

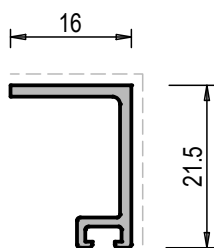

50052

| | | | | |
|-----------------|-----|----|-----------------|--|
| PORTASPAZZOLINO | | Jx | cm ⁴ | |
| PESO | 175 | Jy | cm ⁴ | |
| g/m | | Wx | cm ³ | |
| S. VISTA | --- | Wy | cm ³ | |
| mm | | | | |
| | | | | |
| | | | | |
| | | | | |
| | | | | |
| | | | | |
| | | | | |
| | | | | |

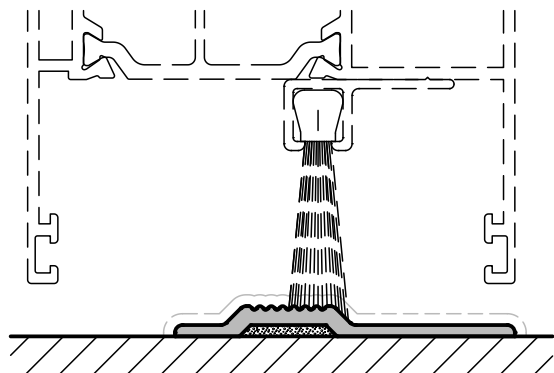

72531

| | | | | |
|---------------|-----|----|-----------------|--|
| SOGLIA PIATTA | | Jx | cm ⁴ | |
| PESO | 226 | Jy | cm ⁴ | |
| g/m | | Wx | cm ³ | |
| S. VISTA | 52 | Wy | cm ³ | |
| mm | | | | |
| | | | | |
| | | | | |
| | | | | |
| | | | | |
| | | | | |
| | | | | |
| | | | | |

COMPLEMENTARI

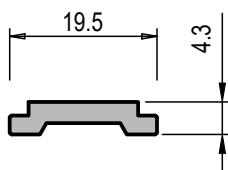

6405

| ASTINA CAMERA EUROPEA | | | Jx | cm ⁴ |
|-----------------------|------|----|-----------------|-----------------|
| PESO | 159 | | Jy | cm ⁴ |
| S. VISTA | ---- | Wx | cm ³ | |
| | | Wy | cm ³ | |

| | | | | |
|--|--|--|--|--|
| | | | | |
| | | | | |
| | | | | |
| | | | | |

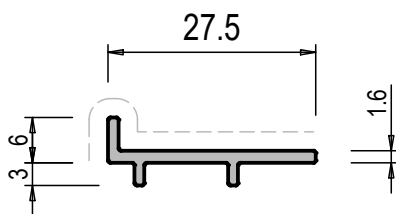

40281

| PROFILATO COMPLEMENTARE PER APERTURA ESTERNA | | | Jx | cm ⁴ |
|--|-----|----|-----------------|-----------------|
| PESO | 156 | | Jy | cm ⁴ |
| S. VISTA | 38 | Wx | cm ³ | |
| | | Wy | cm ³ | |

| | | | | |
|--|--|--|--|--|
| | | | | |
| | | | | |
| | | | | |
| | | | | |

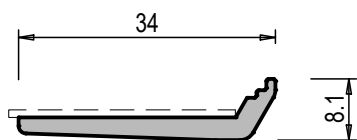

72524

| MANINA SUPPORTO VETRO PER ANTA A SCOMPARSA | | | Jx | cm ⁴ |
|--|-----|----|-----------------|-----------------|
| PESO | 257 | | Jy | cm ⁴ |
| S. VISTA | --- | Wx | cm ³ | |
| | | Wy | cm ³ | |

| | | | | |
|--|--|--|--|--|
| | | | | |
| | | | | |
| | | | | |
| | | | | |

FERMAVETRI

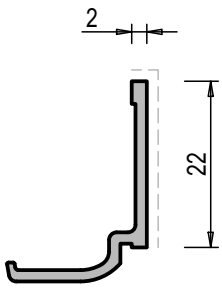

| | |
|--------------|-----|
| 40086 | |
| PESO g/m | 178 |
| S. VISTA mm | 24 |

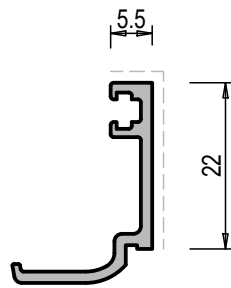

| | |
|--------------|-----|
| 40085 | |
| PESO g/m | 210 |
| S. VISTA mm | 27 |

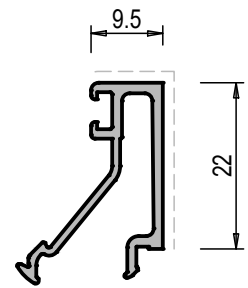

| | |
|--------------|-----|
| 40249 | |
| PESO g/m | 242 |
| S. VISTA mm | 34 |

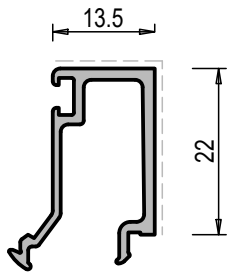

| | |
|--------------|-----|
| 40030 | |
| PESO g/m | 263 |
| S. VISTA mm | 35 |

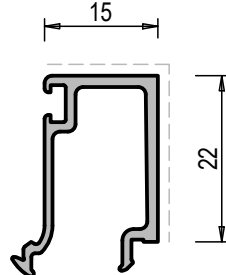

| | |
|--------------|-----|
| 40217 | |
| PESO g/m | 267 |
| S. VISTA mm | 40 |

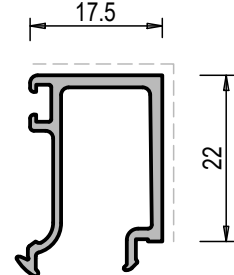

| | |
|--------------|-----|
| 40185 | |
| PESO g/m | 280 |
| S. VISTA mm | 39 |

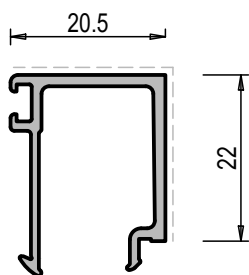

| | |
|--------------|-----|
| 40029 | |
| PESO g/m | 283 |
| S. VISTA mm | 42 |

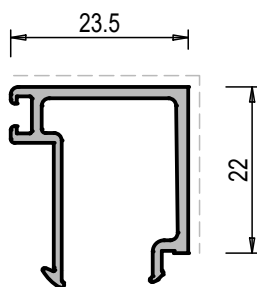

| | |
|--------------|-----|
| 40087 | |
| PESO g/m | 303 |
| S. VISTA mm | 45 |

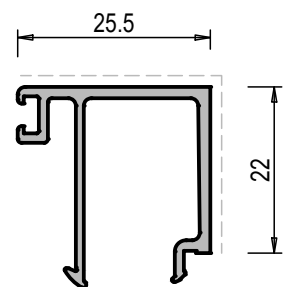

| | |
|--------------|-----|
| 40007 | |
| PESO g/m | 318 |
| S. VISTA mm | 47 |

FERMAVETRI

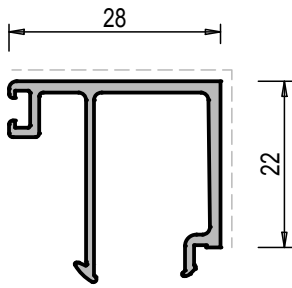

| | |
|--------------|-----|
| 40326 | |
| PESO g/m | 329 |
| S. VISTA mm | 50 |

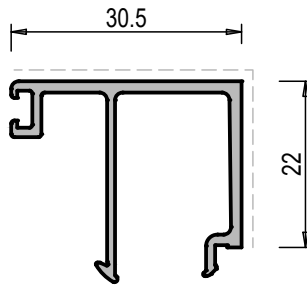

| | |
|--------------|-----|
| 40039 | |
| PESO g/m | 339 |
| S. VISTA mm | 52 |

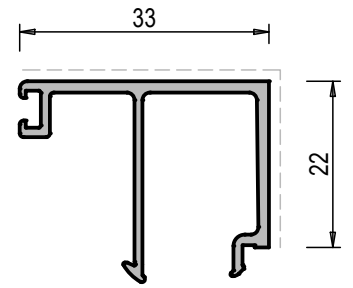

| | |
|--------------|-----|
| 40111 | |
| PESO g/m | 347 |
| S. VISTA mm | 55 |

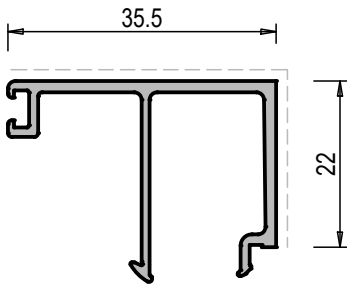

| | |
|--------------|-----|
| 40037 | |
| PESO g/m | 359 |
| S. VISTA mm | 57 |

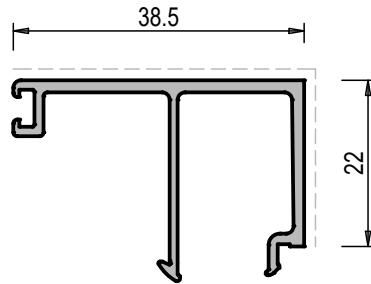

| | |
|--------------|-----|
| 40275 | |
| PESO g/m | 379 |
| S. VISTA mm | 60 |

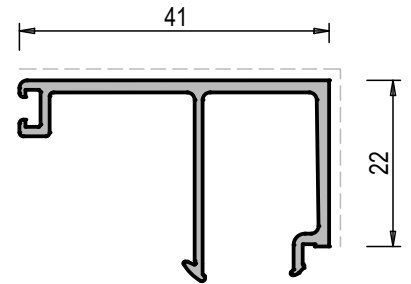

| | |
|--------------|-----|
| 72505 | |
| PESO g/m | 392 |
| S. VISTA mm | 63 |

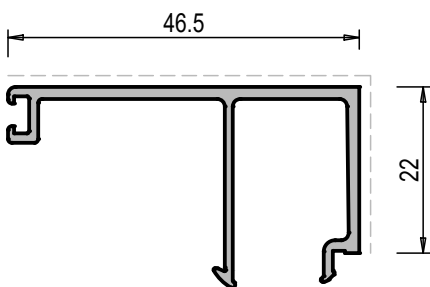

| | |
|--------------|-----|
| 40277 | |
| PESO g/m | 414 |
| S. VISTA mm | 69 |

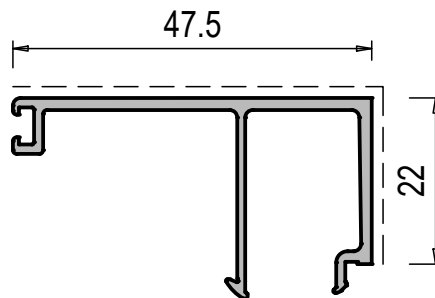

| | |
|--------------|-----|
| 72506 | |
| PESO g/m | 420 |
| S. VISTA mm | 70 |

FERMAVETRI

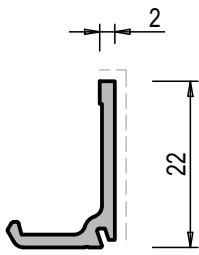

| | |
|--------------|-----|
| 40098 | |
| PESO g/m | 169 |
| S. VISTA mm | 24 |

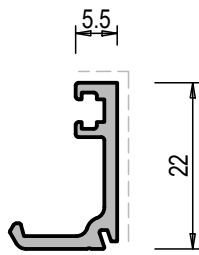

| | |
|--------------|-----|
| 40097 | |
| PESO g/m | 199 |
| S. VISTA mm | 27 |

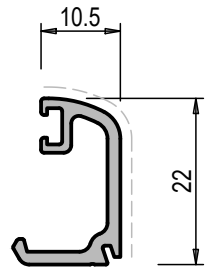

| | |
|--------------|-----|
| 40096 | |
| PESO g/m | 221 |
| S. VISTA mm | 30 |

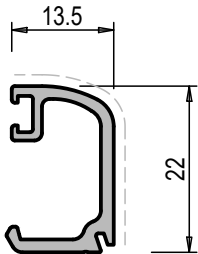

| | |
|--------------|-----|
| 40095 | |
| PESO g/m | 236 |
| S. VISTA mm | 33 |

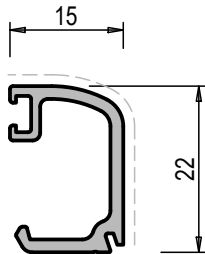

| | |
|--------------|-----|
| 40218 | |
| PESO g/m | 243 |
| S. VISTA mm | 36 |

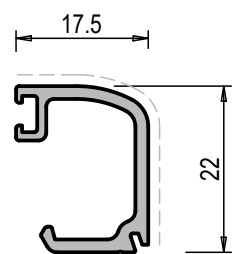

| | |
|--------------|-----|
| 40187 | |
| PESO g/m | 254 |
| S. VISTA mm | 37 |

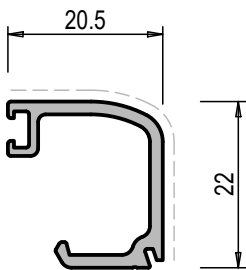

| | |
|--------------|-----|
| 40094 | |
| PESO g/m | 268 |
| S. VISTA mm | 40 |

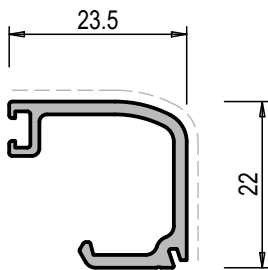

| | |
|--------------|-----|
| 40093 | |
| PESO g/m | 282 |
| S. VISTA mm | 43 |

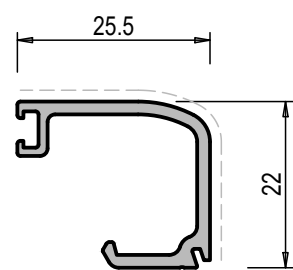

| | |
|--------------|-----|
| 40092 | |
| PESO g/m | 291 |
| S. VISTA mm | 45 |

FERMAVETRI

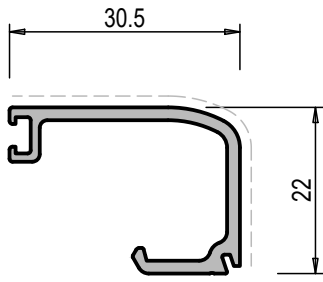

| | |
|----------------|-----|
| 40091 | |
| PESO g/m | 324 |
| S. VISTA mm | 50 |

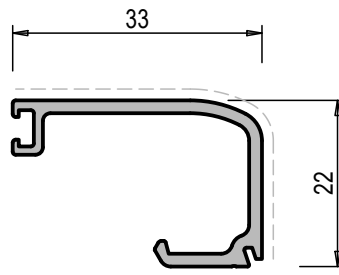

| | |
|----------------|-----|
| 40090 | |
| PESO g/m | 336 |
| S. VISTA mm | 53 |

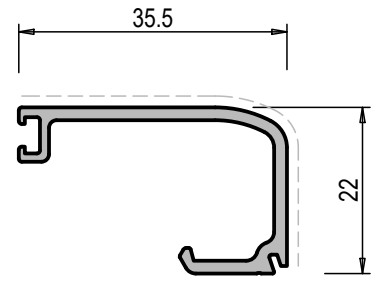

| | |
|----------------|-----|
| 40089 | |
| PESO g/m | 348 |
| S. VISTA mm | 55 |

FERMAVETRI

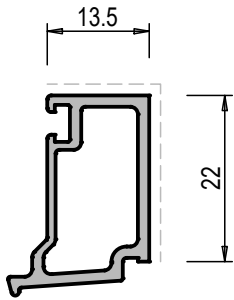

| | |
|--------------|------|
| 40327 | |
| PESO g/m | 311 |
| S. VISTA mm | 35.5 |

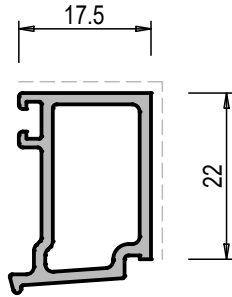

| | |
|--------------|------|
| 41258 | |
| PESO g/m | 342 |
| S. VISTA mm | 39.5 |

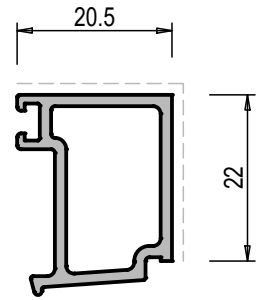

| | |
|--------------|------|
| 41259 | |
| PESO g/m | 359 |
| S. VISTA mm | 42.5 |

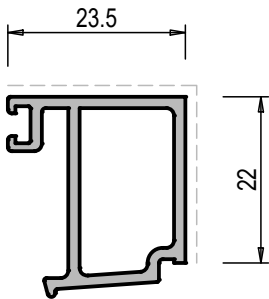

| | |
|--------------|------|
| 40328 | |
| PESO g/m | 425 |
| S. VISTA mm | 45.5 |

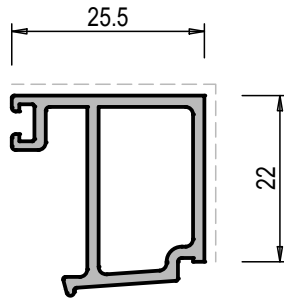

| | |
|--------------|------|
| 72530 | |
| PESO g/m | 395 |
| S. VISTA mm | 47.5 |

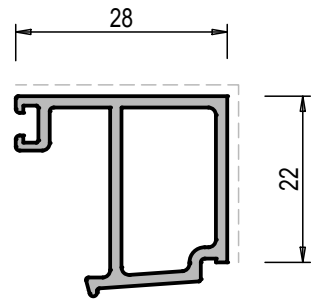

| | |
|--------------|-----|
| 40329 | |
| PESO g/m | 405 |
| S. VISTA mm | 50 |

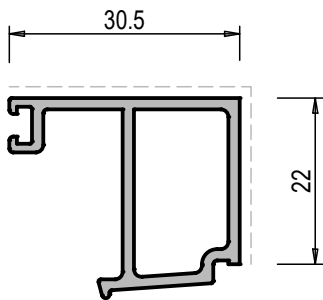

| | |
|--------------|------|
| 72529 | |
| PESO g/m | 415 |
| S. VISTA mm | 52.5 |

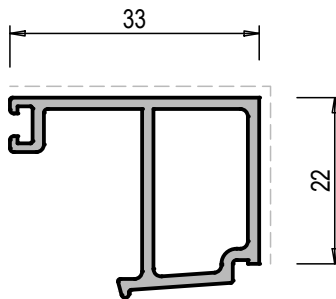

| | |
|--------------|-----|
| 72528 | |
| PESO g/m | 425 |
| S. VISTA mm | 55 |

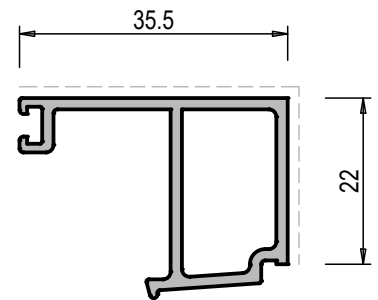

| | |
|--------------|------|
| 72527 | |
| PESO g/m | 435 |
| S. VISTA mm | 57.5 |

FERMAVETRI

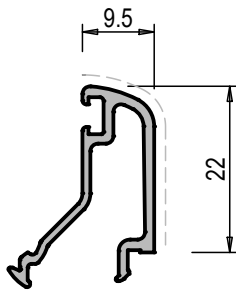

| | |
|----------------|-----|
| 40247 | |
| PESO g/m | 229 |
| S. VISTA mm | 30 |

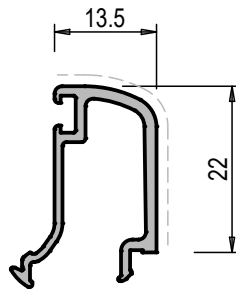

| | |
|----------------|-----|
| 40083 | |
| PESO g/m | 252 |
| S. VISTA mm | 34 |

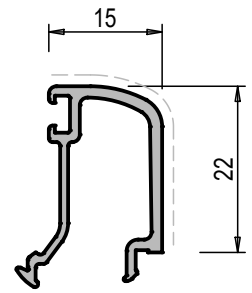

| | |
|----------------|------|
| 40216 | |
| PESO g/m | 259 |
| S. VISTA mm | 52.5 |

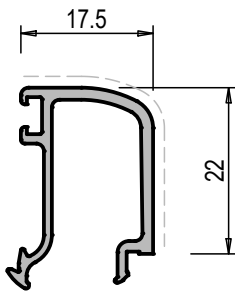

| | |
|----------------|-----|
| 40186 | |
| PESO g/m | 272 |
| S. VISTA mm | 40 |

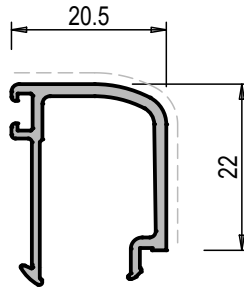

| | |
|----------------|-----|
| 40082 | |
| PESO g/m | 274 |
| S. VISTA mm | 44 |

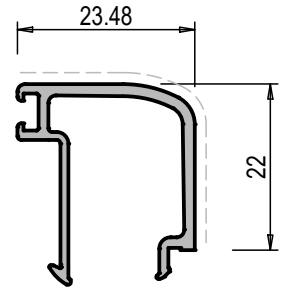

| | |
|----------------|-----|
| 40081 | |
| PESO g/m | 293 |
| S. VISTA mm | 47 |

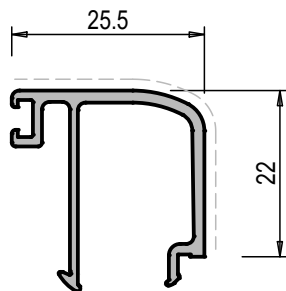

| | |
|----------------|-----|
| 40080 | |
| PESO g/m | 312 |
| S. VISTA mm | 49 |

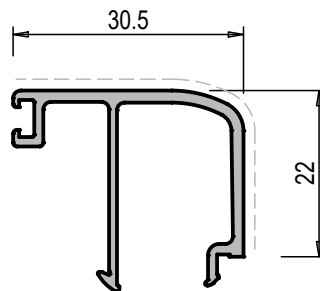

| | |
|----------------|-----|
| 40079 | |
| PESO g/m | 332 |
| S. VISTA mm | 53 |

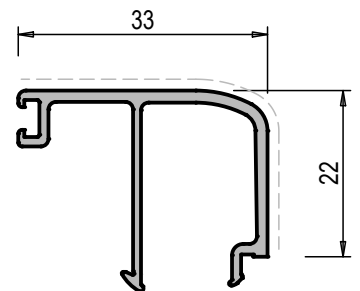

| | |
|----------------|-----|
| 40078 | |
| PESO g/m | 342 |
| S. VISTA mm | 55 |

FERMAVETRI

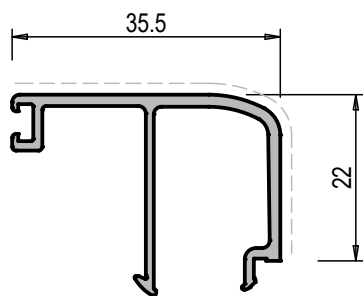

| | |
|--------------|-----|
| 40077 | |
| PESO g/m | 352 |
| S. VISTA mm | 58 |

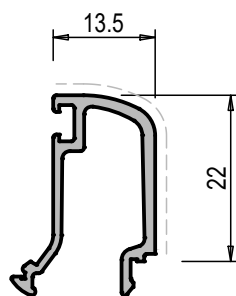

| | |
|--------------|-----|
| 40225 | |
| PESO g/m | 261 |
| S. VISTA mm | 35 |

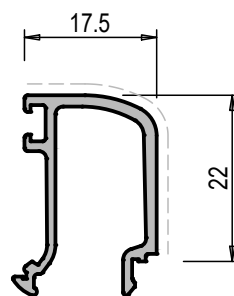

| | |
|--------------|-----|
| 40228 | |
| PESO g/m | 278 |
| S. VISTA mm | 41 |

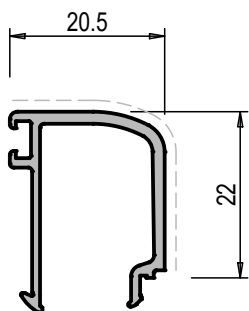

| | |
|--------------|-----|
| 40226 | |
| PESO g/m | 270 |
| S. VISTA mm | 36 |

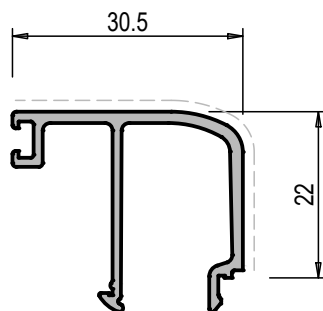

| | |
|--------------|-----|
| 40227 | |
| PESO g/m | 341 |
| S. VISTA mm | 57 |

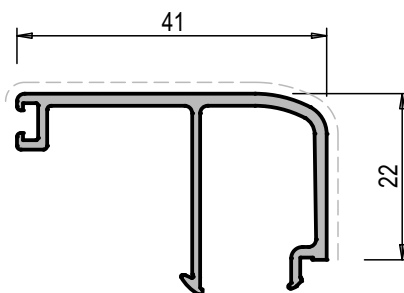

| | |
|--------------|-----|
| 72507 | |
| PESO g/m | 380 |
| S. VISTA mm | 60 |

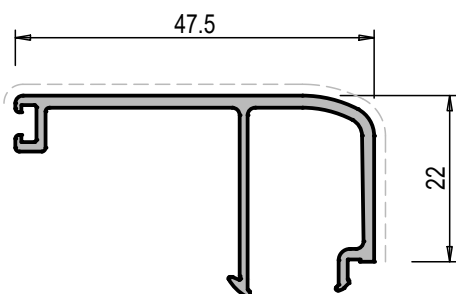

| | |
|--------------|-----|
| 72508 | |
| PESO g/m | 416 |
| S. VISTA mm | 67 |

FERMAVETRI

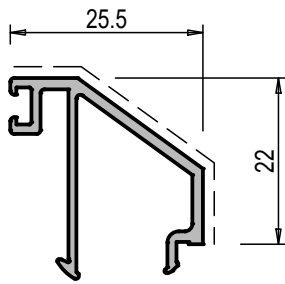

| | |
|----------------|-----|
| 40316 | |
| PESO g/m | 283 |
| S. VISTA mm | 39 |

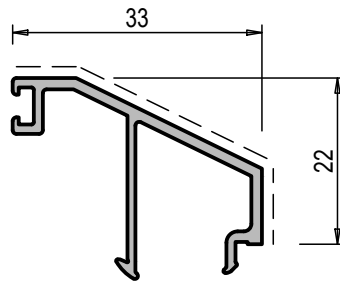

| | |
|----------------|-----|
| 40274 | |
| PESO g/m | 298 |
| S. VISTA mm | 46 |

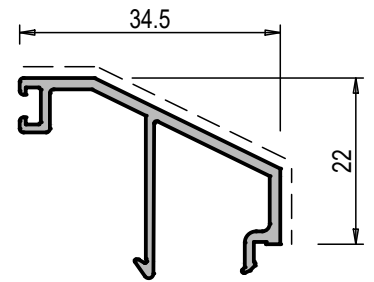

| | |
|----------------|-----|
| 40262 | |
| PESO g/m | 302 |
| S. VISTA mm | 47 |

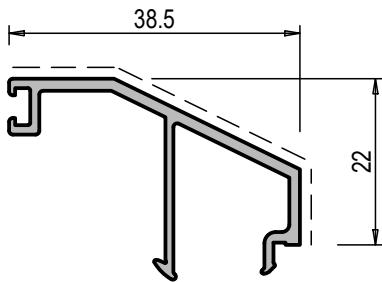

| | |
|----------------|-----|
| 40276 | |
| PESO g/m | 330 |
| S. VISTA mm | 51 |

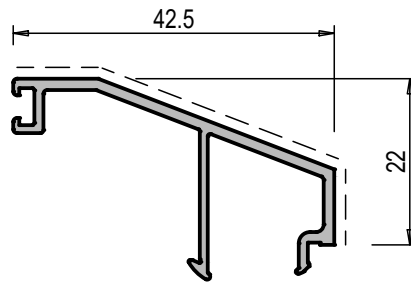

| | |
|----------------|-----|
| 40261 | |
| PESO g/m | 327 |
| S. VISTA mm | 54 |

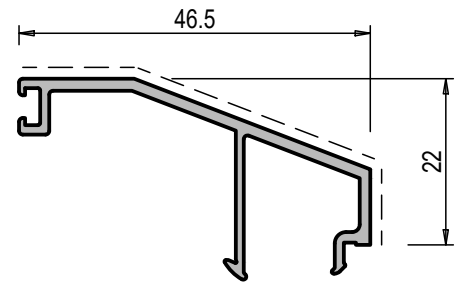

| | |
|----------------|-----|
| 40278 | |
| PESO g/m | 357 |
| S. VISTA mm | 59 |

FERMAVETRI

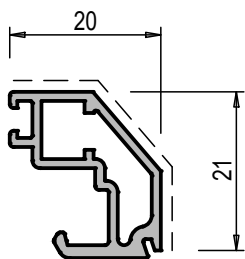

| | |
|----------------|-----|
| 72519 | |
| PESO g/m | 303 |
| S. VISTA mm | 35 |

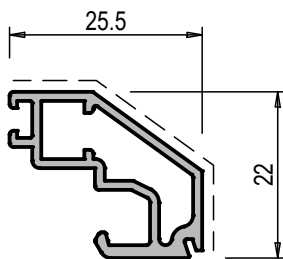

| | |
|----------------|-----|
| 72501 | |
| PESO g/m | 331 |
| S. VISTA mm | 39 |

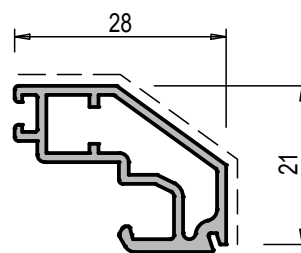

| | |
|----------------|-----|
| 72512 | |
| PESO g/m | 348 |
| S. VISTA mm | 42 |

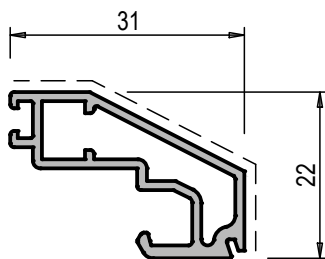

| | |
|----------------|-----|
| 72502 | |
| PESO g/m | 364 |
| S. VISTA mm | 45 |

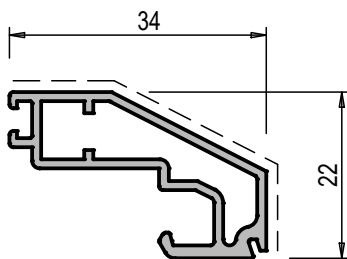

| | |
|----------------|-----|
| 72509 | |
| PESO g/m | 382 |
| S. VISTA mm | 48 |

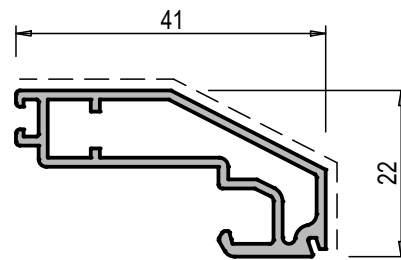

| | |
|----------------|-----|
| 72503 | |
| PESO g/m | 428 |
| S. VISTA mm | 55 |

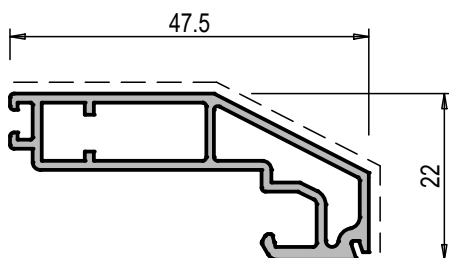

| | |
|----------------|-----|
| 72504 | |
| PESO g/m | 492 |
| S. VISTA mm | 61 |

FERMAVETRI

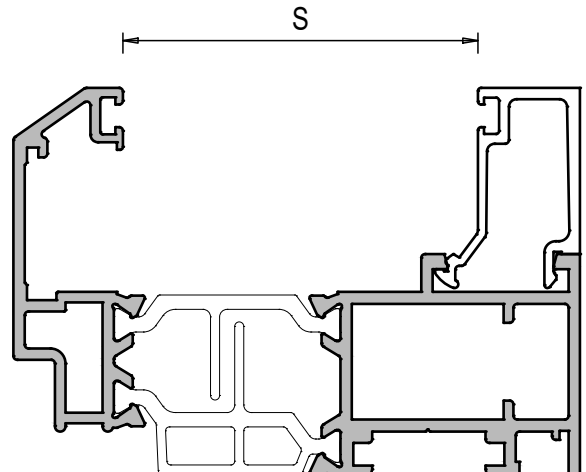
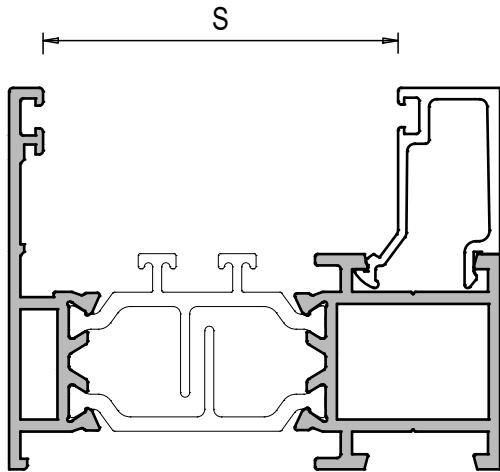

LA MISURA **S** INDICA LO SPAZIO UTILE PER L'ALLOGGIAMENTO DEL VETRO. SOTTRARRE L'INGOMBRO DELLA GUARNIZIONE CINGIVETRO INTERNA ED ESTERNA CHE VIENE UTILIZZATA

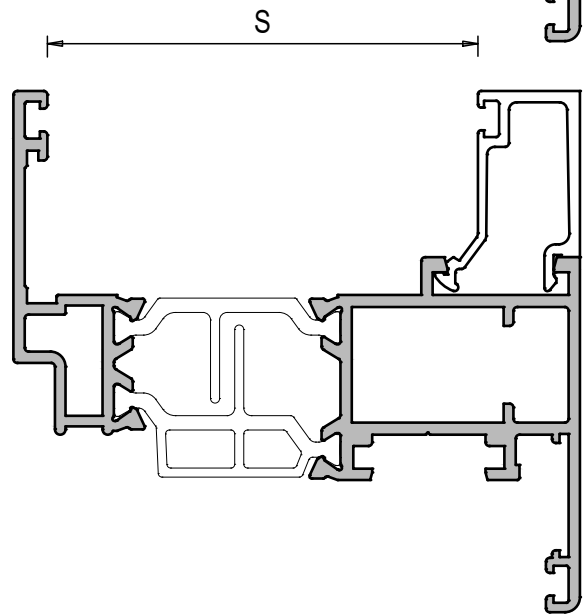

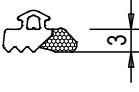

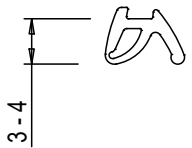
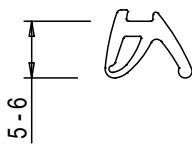
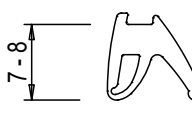
| CINGIVETRO ESTERNA | |
|---|------------------|
|  | TG032 DA mm 3 |

| CINGIVETRO INTERNA | |
|--|----------------------------|
|  | TG304 DA mm 3 A mm 4 |
|  | TG305 DA mm 5 A mm 6 |
|  | TG306 DA mm 5 A mm 6 |

APPLICAZIONE FERMAVETRI



| MISURE FERMAVETRO | PIANI | ARROTONDATI | CLIP | CONTRASTO | DESIGN | DESIGN CLIP |  |  |
|-------------------|-------|-------------|-------|-----------|--------|-------------|---|---|
| 2 mm | 40086 | | 40098 | | | | S = 58.5 | S = 68.5 |
| 5.5 mm | 40085 | | 40097 | | | | S = 55 | S = 65 |
| 9.5 mm | 40249 | 40247 | | | | | S = 51 | S = 61 |
| 10.5 mm | 40031 | | 40096 | | | | S = 50 | S = 60 |
| 13.5 mm | 40030 | 40083 | 40095 | 40327 | | | S = 47 | S = 57 |
| 15 mm | 40217 | 40216 | 40218 | | | | S = 45.5 | S = 55.5 |
| 17.5 mm | 40185 | 40186 | 40187 | 41258 | | | S = 43 | S = 53 |
| 20 mm | | | | | | 72519 | S = 40.5 | S = 50.5 |
| 20.5 mm | 40029 | 40082 | 40094 | 41259 | | | S = 40 | S = 50 |
| 23.5 mm | 40087 | 40081 | 40093 | 40328 | | | S = 37 | S = 47 |
| 25.5 mm | 40007 | 40080 | 40092 | 72530 | 40316 | 72501 | S = 35 | S = 45 |
| 28 mm | 40326 | | | 40328 | | 72512 | S = 32.5 | S = 42.5 |
| 30.5 mm | 40039 | 40079 | 40091 | 72529 | | | S = 30 | S = 40 |
| 31 mm | | | | | | 72502 | S = 29.5 | S = 39.5 |
| 33 mm | 40111 | 40078 | 40090 | 72528 | 40274 | | S = 27.5 | S = 37.5 |
| 34 mm | | | | | | 72509 | S = 26.5 | S = 36.5 |
| 34.5 mm | | | | | 40262 | | S = 26 | S = 36 |
| 35.5 mm | 40037 | 40077 | 40089 | 72527 | | | S = 25 | S = 35 |
| 38.5 mm | 40275 | | | | 40276 | | S = 22 | S = 32 |
| 41 mm | 72505 | 72507 | | | | 72503 | S = 19.5 | S = 29.5 |
| 42.5 mm | | | | | 40261 | | S = 18 | S = 28 |
| 46.5 mm | 40277 | | | | 40278 | | S = 14 | S = 24 |
| 47.5 mm | 72506 | 72508 | | | | 72504 | S = 13 | S = 23 |
| 52.5 mm | 40279 | | | | 40280 | | S = 8 | S = 18 |

Profilati Scala 1:1



MONTAGGIO FERMAVETRI

LA ROTAZIONE DEL FERMAVETRO IN FASE DI MONTAGGIO OCCUPA UNO SPAZIO DI 4mm.
PER L'INSERIMENTO AGEVOLE, CONSIDERARE UNO SPAZIO ANCORA MAGGIORE.

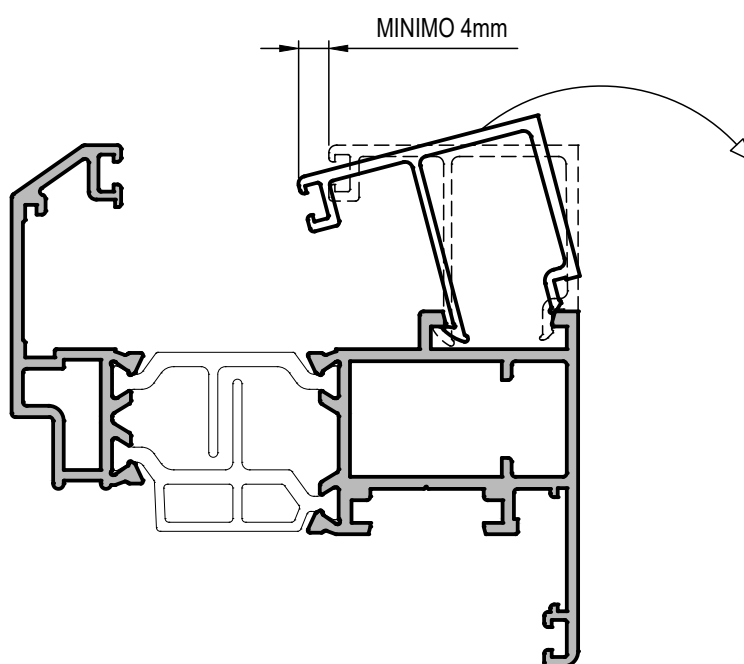

N.B. PRIMA DI ESEGUIRE IL LAVORO, CONTROLLARE COMUNQUE CHE LA ROTAZIONE DEL FERMAVETRO AVVENGA REGOLARMENTE E NON SIA INFLUENZATA ANCHE DA EVENTUALI TOLLERANZE DEL VETROCAMERA.

LA ROTAZIONE DEL FERMAVETRO IN FASE DI MONTAGGIO OCCUPA UNO SPAZIO DI 4mm.

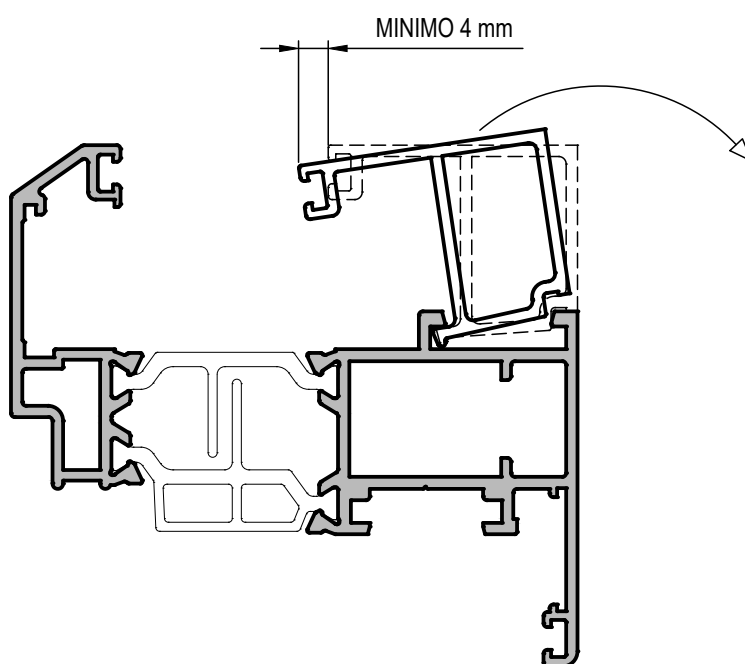

N.B. PRIMA DI ESEGUIRE IL LAVORO, CONTROLLARE COMUNQUE CHE LA ROTAZIONE DEL FERMAVETRO AVVENGA REGOLARMENTE E NON SIA INFLUENZATA ANCHE DA EVENTUALI TOLLERANZE DEL VETROCAMERA.
DURANTE LA FASE DI TRASPORTO INSERIRE UNO SPESSORE PER STABILIZZARE I FERMAVETRI.



Soluzioni Disponibili 

SEZIONE TIPO DOGMA

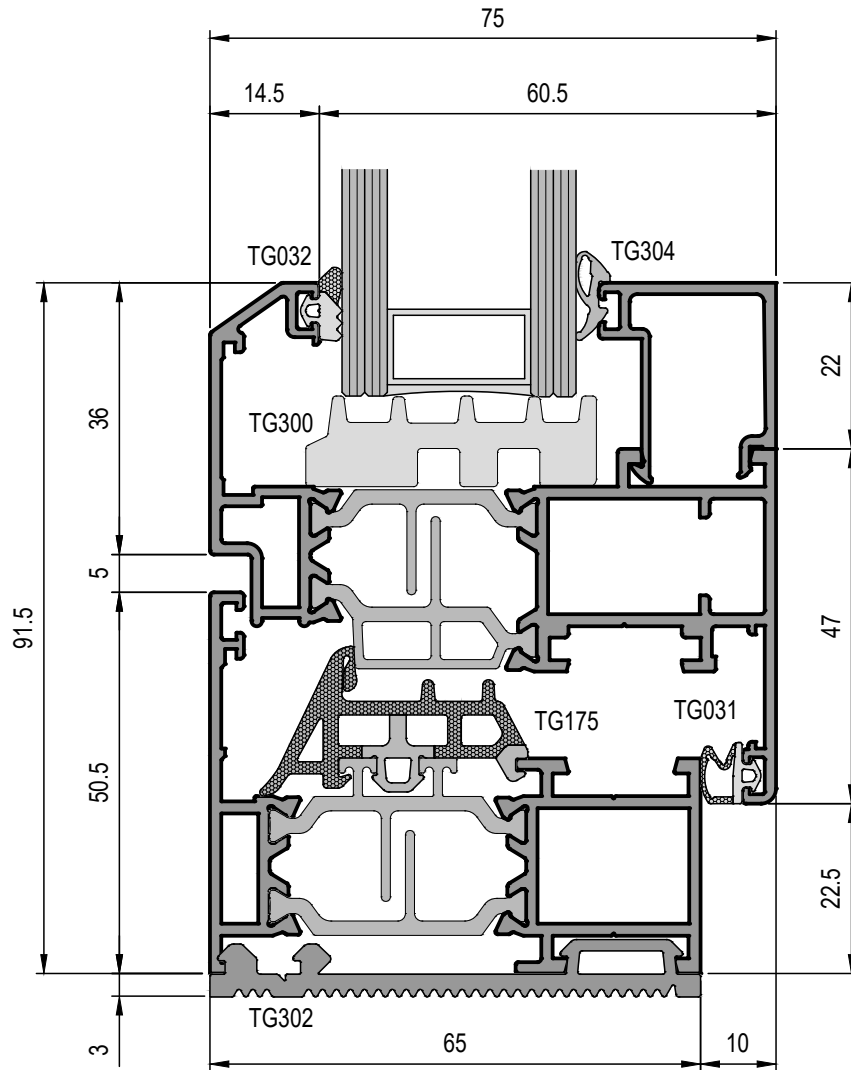

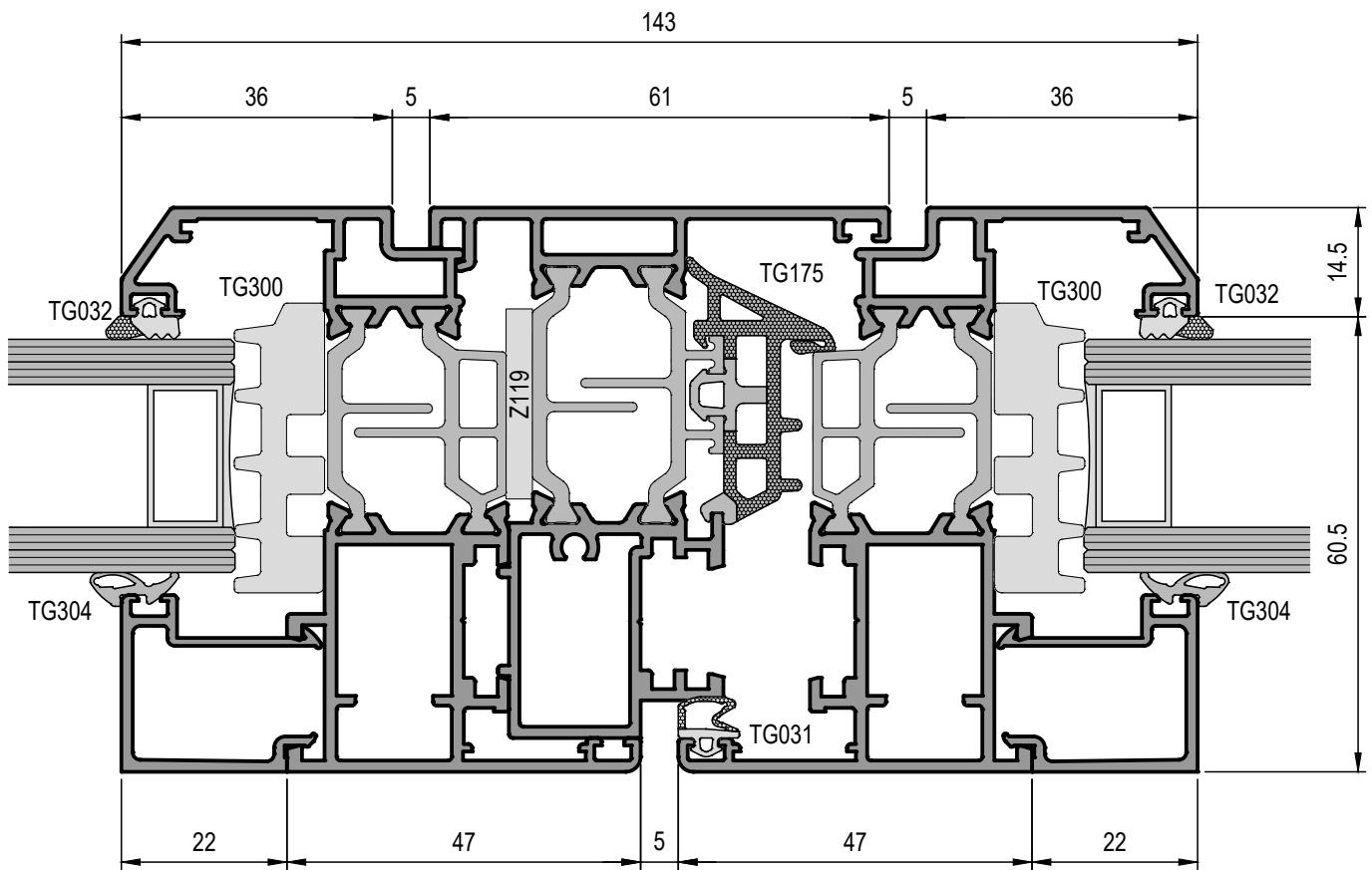

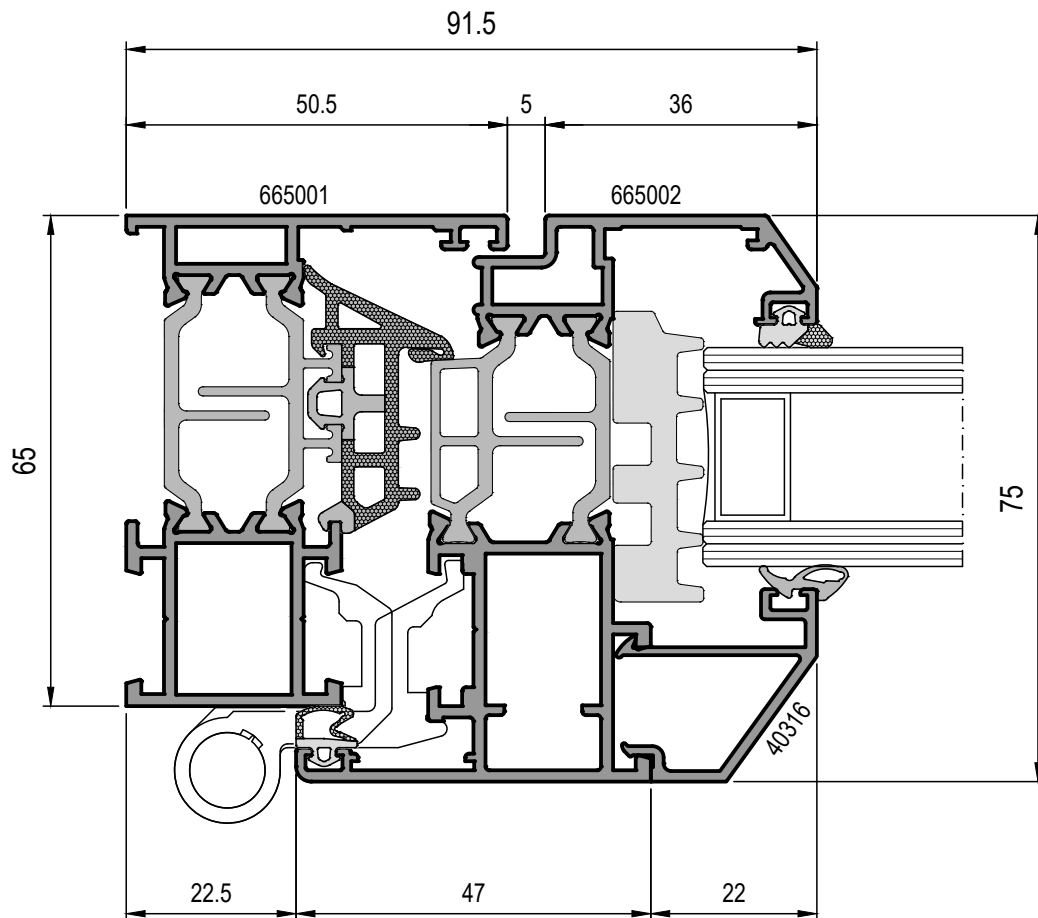

LINEA SGUSCIATA

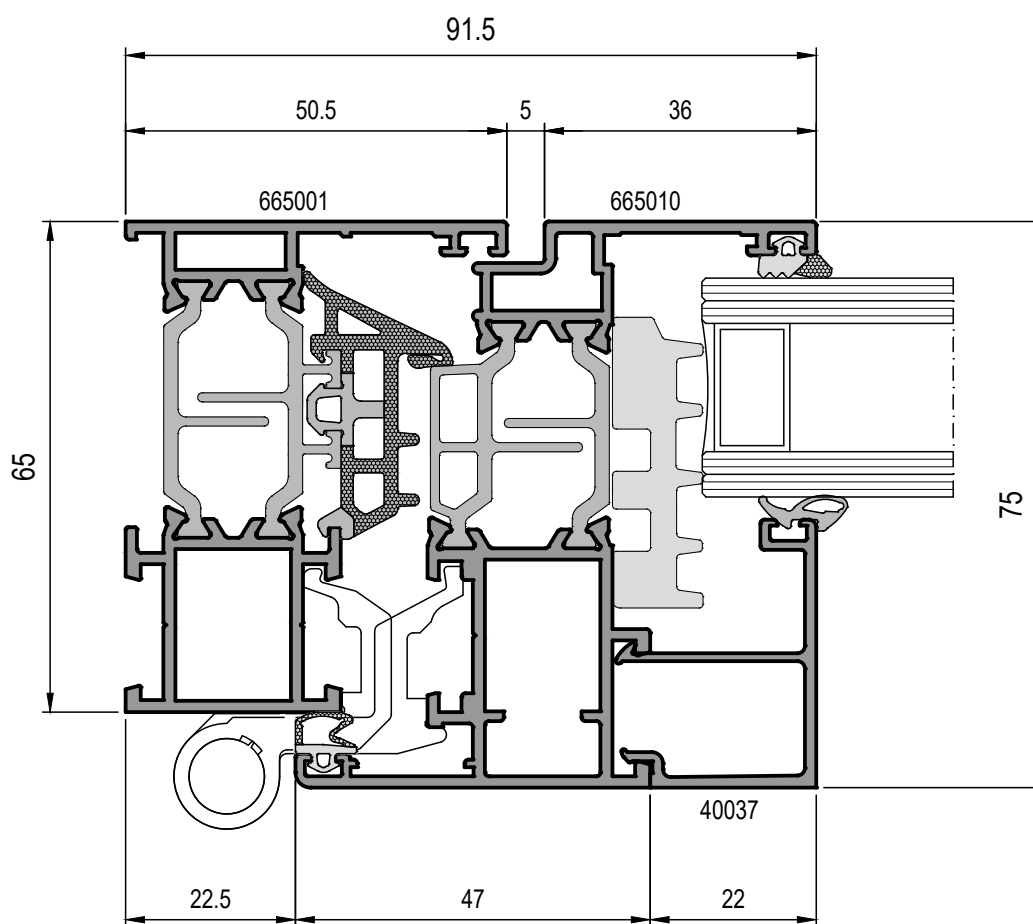

LINEA PIANA

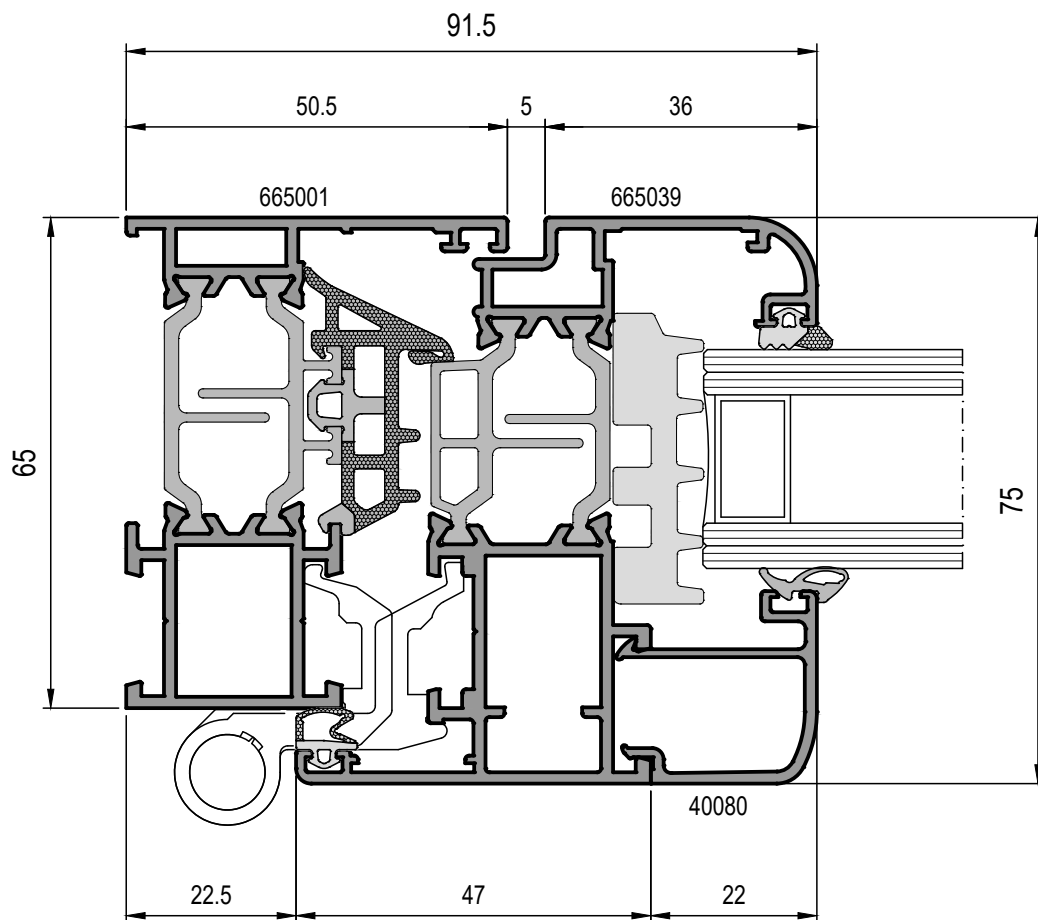
**LINEA ARROTONDATA**

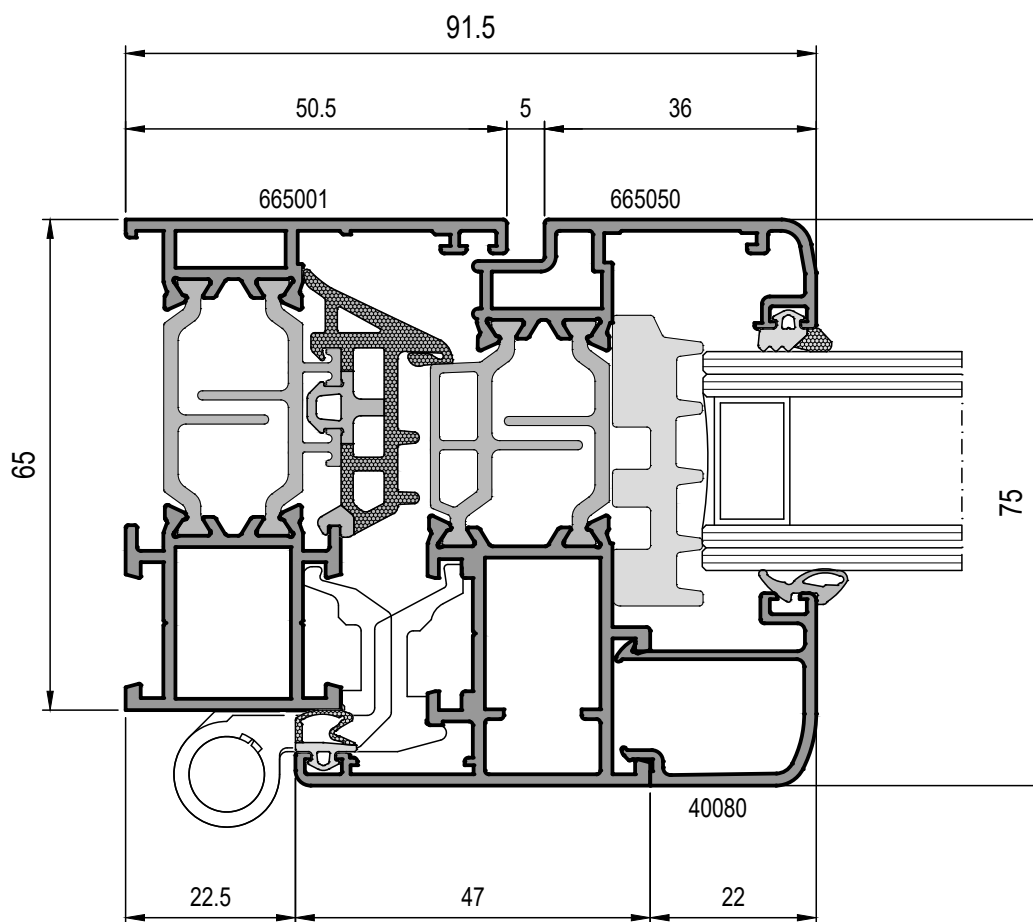











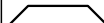
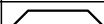

LINEA STORICA

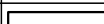

Schede di Taglio 

FINESTRA AD UN' ANTA GIUNTO APERTO APERTURA INTERNA

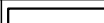
DISTINTA PROFILATI

| CODICE | PROFILATO | DESCRIZIONE | MISURA TAGLIO | TAGLIO | N° |
|---------|---|-------------------|----------------------------------|---|----------------------------------|
| 665000 |  | TELAIO Z | L + 52 |  | 1 |
| | | | H + 52 |  | 2 |
| 665001 |  | TELAIO L | L |  | 1 |
| 665002 |  | ANTA Z | L - 45 |  | 2 |
| | | | H - 45 |  | 2 |
| 40087 |  | FERMAVETRO | L - 139 |  | 2 |
| | | | H - 183 |  | 2 |
| 40081 * |  | FERMAVETRO | L - 183 |  | 2 |
| | | | H - 183 |  | 2 |
| 6405 |  | ASTINA DI COMANDO | DIPENDE DA ACCESSORIO DI COMANDO |  | DIPENDE DA ACCESSORIO DI COMANDO |

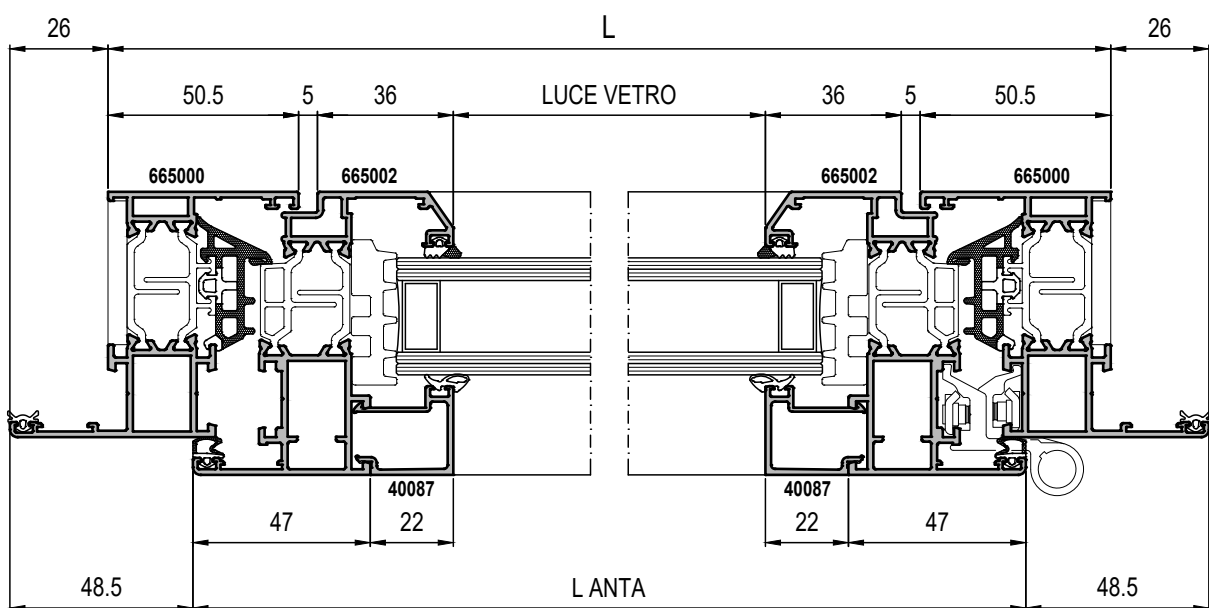
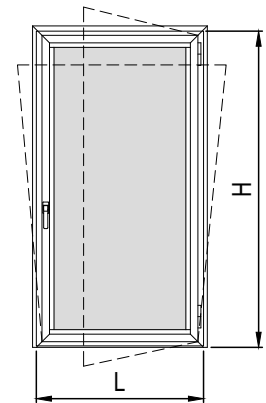

DISTINTA ACCESSORI

| CODICE | DESCRIZIONE | N° |
|------------------|---|---------|
| TA075 | REGOLO TELAIO CAMERA SEMPLICE | TABELLA |
| G2001 | VITE PER SQUADRETTA TS078 | 16 |
| G2002 * | SPINA PER SQUADRETTA TS078 | |
| TS077 | SQUADRETTA A PULSANTE PER TELAIO ED ANTA | 8 |
| TS078 * | SQUADRETTA A SPINARE-CIANFRINARE TELAIO ED ANTA | |
| G501N | SQUADRETTA A CAMME PER TELAIO E ANTA | 8 |
| TS079 | SQUADRETTA ANTA E TELAIO TUBOLARITÀ ESTERNA | 8 |
| S3001 | SPINA MM 3 PER SQUADRETTA TS079 | 8 |
| G112 | SQUADRETTA INOX DI ALLINEAMENTO ANGOLI | 4 |
| G268 | SQUADRETTA ALLINEAMENTO ANTE | 4 |
| G269 | SQUADRETTA ALLINEAMENTO TELAIO | 2 |
| G101 | CAPPETTA DRENAGGIO ACQUA | 2 ... 3 |
| G231* | ANGOLO PRESSOFUSO PER FERMAVETRI ARROTONDATI | 4 |
| * IN ALTERNATIVA | | |

N.B. : PER GLI ACCESSORI DI CHIUSURA, MOVIMENTAZIONE E LIMITI PRESTAZIONALI CONSULTARE IL MANUALE DEL FORNITORE DEGLI ACCESSORI.

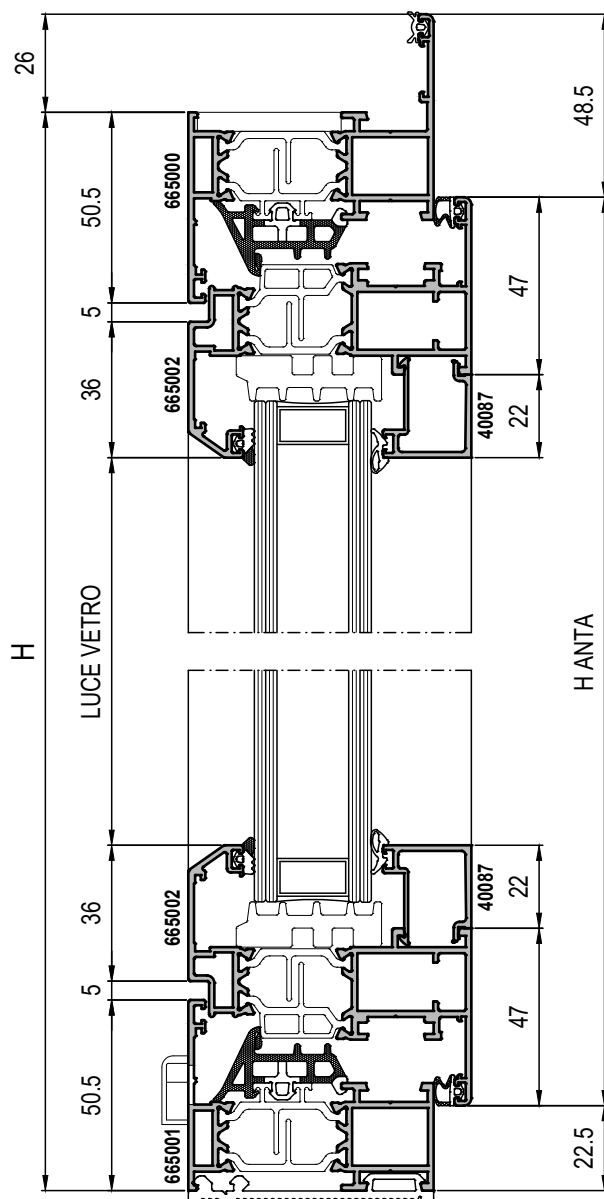









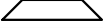

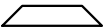
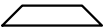

DISTINTA GUARNIZIONI

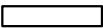
| CODICE | DESCRIZIONE | N° |
|------------------|--|-------|
| TG176 | ANGOLO VULCANIZZATO | 4 Pz. |
| TG175 | GUARNIZIONE DI TENUTA CENTRALE | 2L+2H |
| TG031 | GUARNIZIONE DI BATTUTA | 2L+2H |
| | GUARNIZIONE CINGIVETRO ESTERNA | 2L+2H |
| | GUARNIZIONE CINGIVETRO INTERNA | 2L+2H |
| TG302 | GUARNIZIONE PERIMETRALE ISOLANTE | L |
| TG004 | GUARNIZIONE BATTUTA A MURO / BATTUTA ESTERNA | L+2H |
| TG300 | SOTTOVETRO ISOLANTE | 2L+2H |
| Z119 | GUARNIZIONE ISOLANTE | L+2H |
| * IN ALTERNATIVA | | |

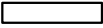
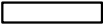
FINESTRA A DUE ANTE GIUNTO APERTO APERTURA INTERNA

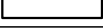
DISTINTA PROFILATI

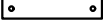
| CODICE | PROFILATO | DESCRIZIONE | MISURA TAGLIO | TAGLIO | N° |
|---------|---|-------------------|----------------------------------|---|----------------------------------|
| 665000 |  | TELAIO Z | L + 52 |  | 1 |
| | | | H + 52 |  | 2 |
| 665001 |  | TELAIO L | L |  | 1 |
| 665002 |  | ANTA Z | L/2 - 25 |  | 4 |
| | | | H - 45 |  | 4 |
| 665003 |  | RIPORTO | H - 111 |  | 1 |
| 40087 |  | FERMAVETRO | L/2 - 119 |  | 4 |
| | | | H - 183 |  | 4 |
| 40081 * |  | FERMAVETRO | L/2 - 163 |  | 4 |
| | | | H - 183 |  | 4 |
| 6405 |  | ASTINA DI COMANDO | DIPENDE DA ACCESSORIO DI COMANDO |  | DIPENDE DA ACCESSORIO DI COMANDO |

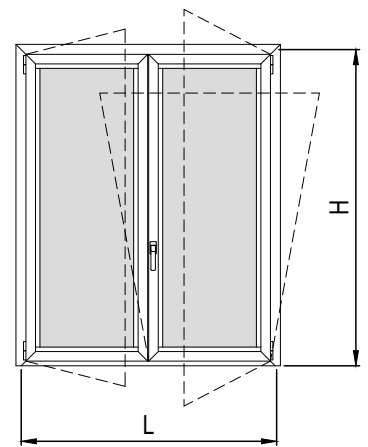

VISTA INTERNA

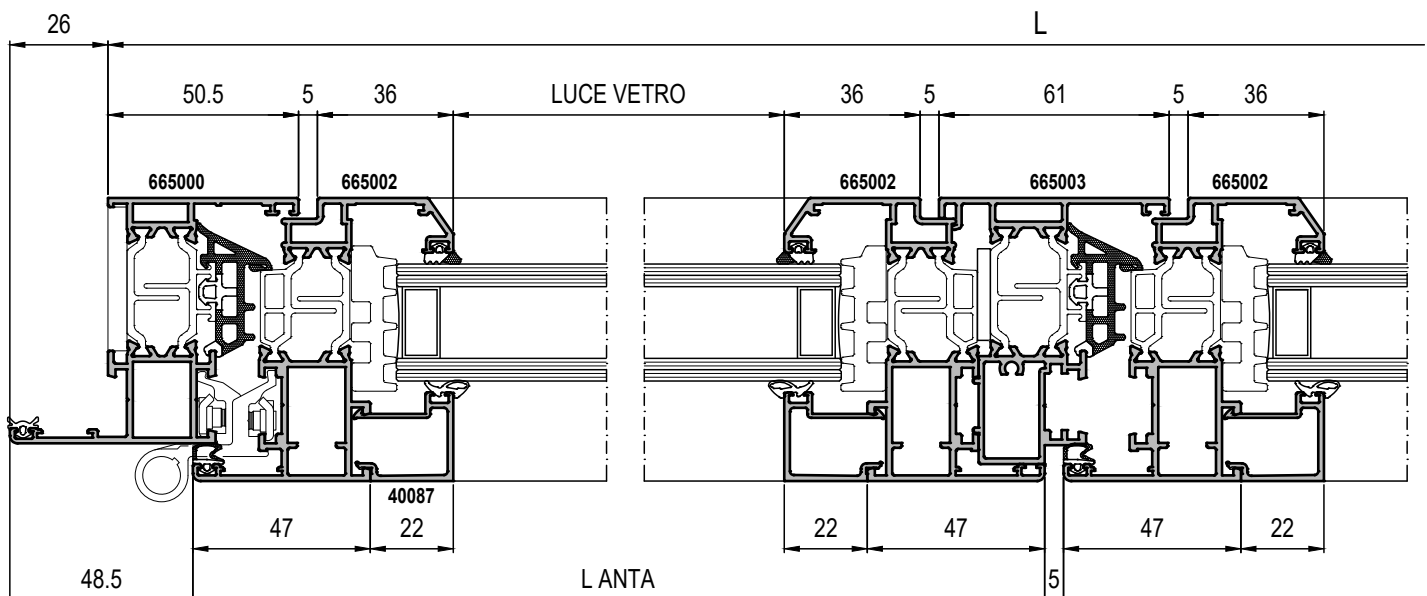

DISTINTA ACCESSORI

| CODICE | DESCRIZIONE | N° |
|------------------|---|---------|
| TA075 | REGOLO TELAIO CAMERA SEMPLICE | TABELLA |
| G2001 | VITE PER SQUADRETTA TS078 | 24 |
| G2002 * | SPINA PER SQUADRETTA TS078 | |
| TS077 | SQUADRETTA A PULSANTE PER TELAIO ED ANTA | 12 |
| TS078 * | SQUADRETTA A SPINARE-CIANFRINARE PER TELAIO ED ANTA | |
| G501N | SQUADRETTA A CAMME PER ANTE | 12 |
| TS079 | SQUADRETTA ANTA E TELAIO TUBOLARITÀ ESTERNA | 12 |
| S3001 | SPINA MM 3 PER SQUADRETTA TS079 | 24 |
| G112 | SQUADRETTA INOX DI ALLINEAMENTO ANGOLI | 4 |
| G268 | SQUADRETTA ALLINEAMENTO ANTE | 8 |
| G269 | SQUADRETTA ALLINEAMENTO TELAIO | 2 |
| TT065 | COPPIA TAPPI RIPORTO CENTRALE | 1 Cp. |
| G101 | CAPPETTA DI DRENAGGIO ACQUA | 2...4 |
| G231* | ANGOLO PRESSOFUSO PER FERMAVETRI ARROTONDATI | 8 |
| * IN ALTERNATIVA | | |

N.B. : PER GLI ACCESSORI DI CHIUSURA, MOVIMENTAZIONE E LIMITI PRESTAZIONALI CONSULTARE IL MANUALE DEL FORNITORE DEGLI ACCESSORI.

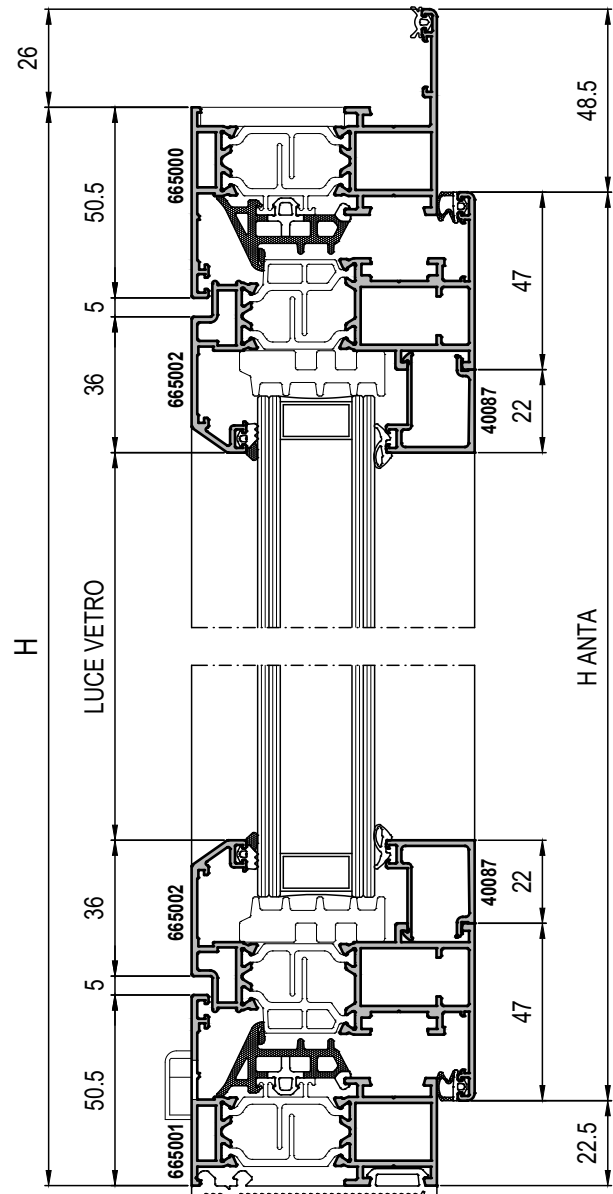
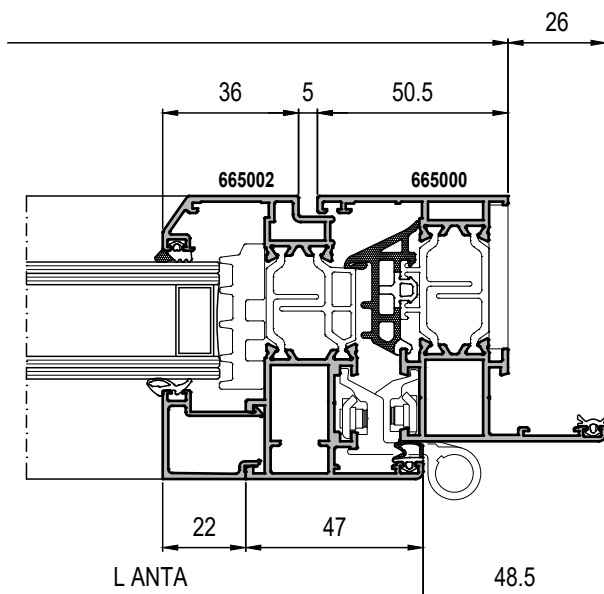



























DISTINTA GUARNIZIONI

| CODICE | DESCRIZIONE | N° |
|------------------|----------------------------------|-------|
| TG176 | ANGOLO VULCANIZZATO | 4 Pz. |
| TG175 | GUARNIZIONE DI TENUTA CENTRALE | 2L+3H |
| TG031 | GUARNIZIONE DI BATTUTA | 2L+4H |
| | GUARNIZIONE CINGIVETRO ESTERNA | 2L+4H |
| | GUARNIZIONE CINGIVETRO INTERNA | 2L+4H |
| TG302 | GUARNIZIONE PERIMETRALE ISOLANTE | L |
| TG004 | GUARNIZIONE BATTUTA A MURO | L+2H |
| TG300 | SOTTOVETRO ISOLANTE | 2L+4H |
| Z119 | GUARNIZIONE ISOLANTE | L+2H |
| * IN ALTERNATIVA | | |

PORTAFINESTRA A DUE ANTE GIUNTO APERTO APERTURA INTERNA

DISTINTA PROFILATI

| CODICE | PROFILATO | DESCRIZIONE | MISURA TAGLIO | TAGLIO | N° |
|---------|---|-----------------------------|----------------------------------|---|----------------------------------|
| 665000 |  | TELAIO Z | L + 52 |  | 1 |
| | | | H + 52 |  | 2 |
| 665002 |  | ANTA Z | L/2 - 25 |  | 4 |
| | | | H - 30.5 |  | 4 |
| 665003 |  | RIPORTO | H - 96.5 |  | 1 |
| 40087 |  | FERMAVETRO | L/2 - 119 |  | 8 |
| | | | H1 - 213,25 |  | 4 |
| | | | H2 - 127,75 |  | 4 |
| 40081 * |  | FERMAVETRO | L/2 - 163 |  | 8 |
| | | | H1 - 213,25 |  | 4 |
| | | | H2 - 127,75 |  | 4 |
| 665034 |  | SOGLIA RIBASSATA | L - 47.5 |  | 1 |
| 665250 |  | CARTELLINA SOGLIA RIBASSATA | L |  | 1 |
| 665024 |  | ZOCCOLO RIPORTATO | L/2 - 109.5 |  | 2 |
| 665020 |  | TRAVERSO | L/2 - 109.5 |  | 2 |
| 6405 |  | ASTINA DI COMANDO | DIPENDE DA ACCESSORIO DI COMANDO |  | DIPENDE DA ACCESSORIO DI COMANDO |

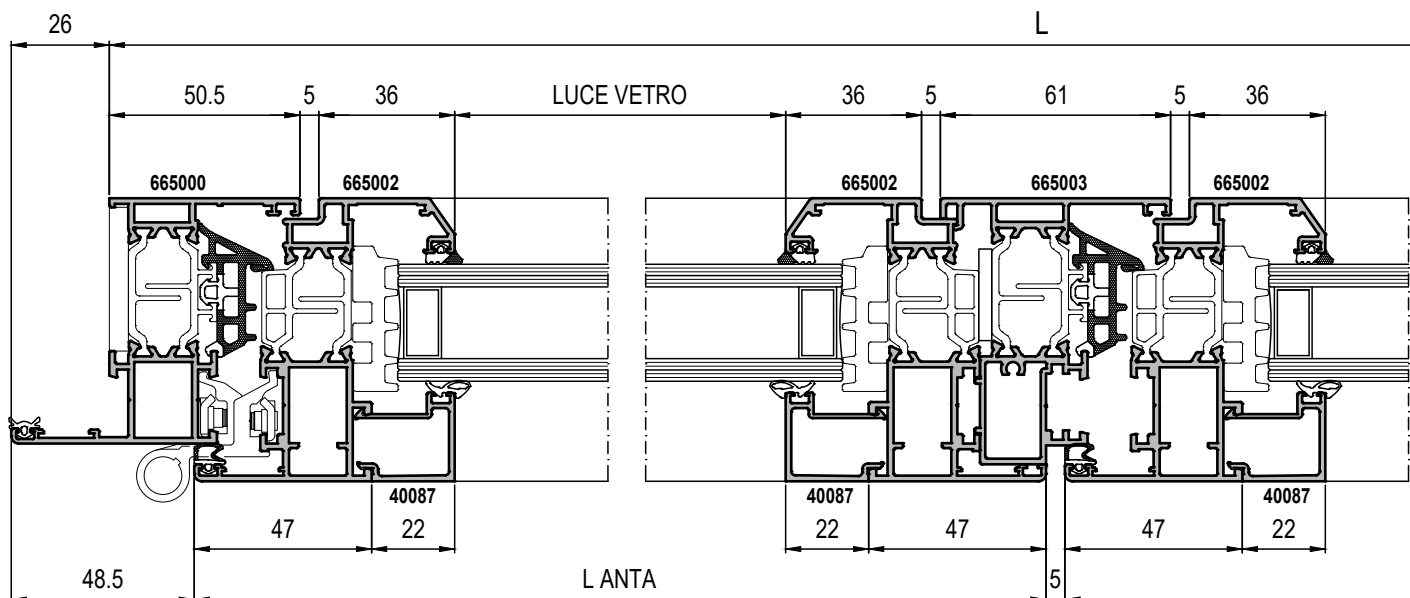
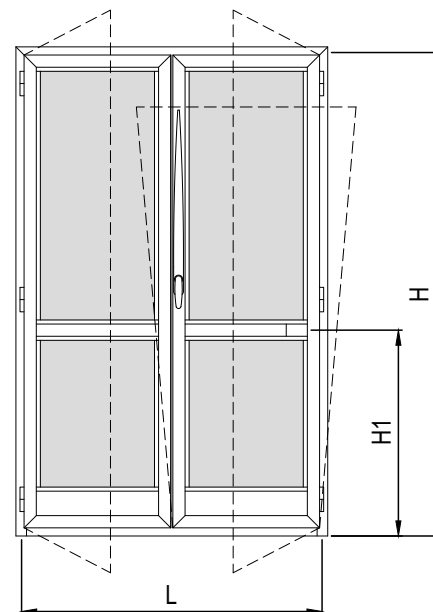

DISTINTA ACCESSORI

| CODICE | DESCRIZIONE | N° |
|---------|---|---------|
| TA075 | REGOLO TELAIO CAMERA SEMPLICE | TABELLA |
| G2001 | VITE PER SQUADRETTA TS078 | 24 |
| G2002 * | SPINA PER SQUADRETTA TS078 | |
| TS077 | SQUADRETTA A BOTTONE PER TELAIO ED ANTA | 12 |
| TS078 * | SQUADRETTA A SPINARE-CIANFRINARE PER TELAIO ED ANTA | |
| G501N | SQUADRETTA A CAMME PER ANTE | 10 |
| TS079 | SQUADRETTA ANTA E TELAIO TUBOLARITÀ ESTERNA | 10 |
| G501N | CAVALLOTTO ESTERNO | 12 |
| TS082 | PLACCHETTA DI COMPENSAZIONE PER G501N CAVALLOTTO | 8 |
| G199 | CAVALLOTTO INTERNO | 4 |
| TS073 | CAVALLOTTO ESTERNO TRASVERSO | 4 |
| TS074 | CAVALLOTTO ESTERNO ZOCCOLO RIPORTATO | 4 |
| S3001 | SPINA MM 3 PER SQUADRETTA TS079 | 20 |
| G112 | SQUADRETTA INOX DI ALLINEAMENTO ANGOLI | 2 |
| G268 | SQUADRETTA ALLINEAMENTO ANTE | 8 |
| G269 | SQUADRETTA ALLINEAMENTO TELAIO | 2 |
| TT065 | COPPIA TAPPI RIPIRTO CENTRALE | 1 Cp. |
| G101 | CAPPETTA DI DRENAGGIO ACQUA | 2...4 |
| G231* | ANGOLO PRESSOFUSO PER FERMAVETRI ARROTONDATI | 8 |

* IN ALTERNATIVA

DISTINTA GUARNIZIONI

| CODICE | DESCRIZIONE | N° |
|--------|--------------------------------|-------|
| TG176 | ANGOLO VULCANIZZATO | 4 Pz. |
| TG175 | GUARNIZIONE DI TENUTA CENTRALE | 2L+3H |
| TG031 | GUARNIZIONE DI BATTUTA | 2L+4H |
| | GUARNIZIONE CINGIVETRO ESTERNA | 4L+4H |
| | GUARNIZIONE CINGIVETRO INTERNA | 4L+4H |
| TG004 | GUARNIZIONE BATTUTA A MURO | L+2H |
| TG300 | SOTTOVETRO ISOLANTE | 4L+4H |
| Z119 | GUARNIZIONE ISOLANTE | L+4H |

* IN ALTERNATIVA

N.B. : PER GLI ACCESSORI DI CHIUSURA, MOVIMENTAZIONE E LIMITI PRESTAZIONALI CONSULTARE IL MANUALE DEL FORNITORE DEGLI ACCESSORI.

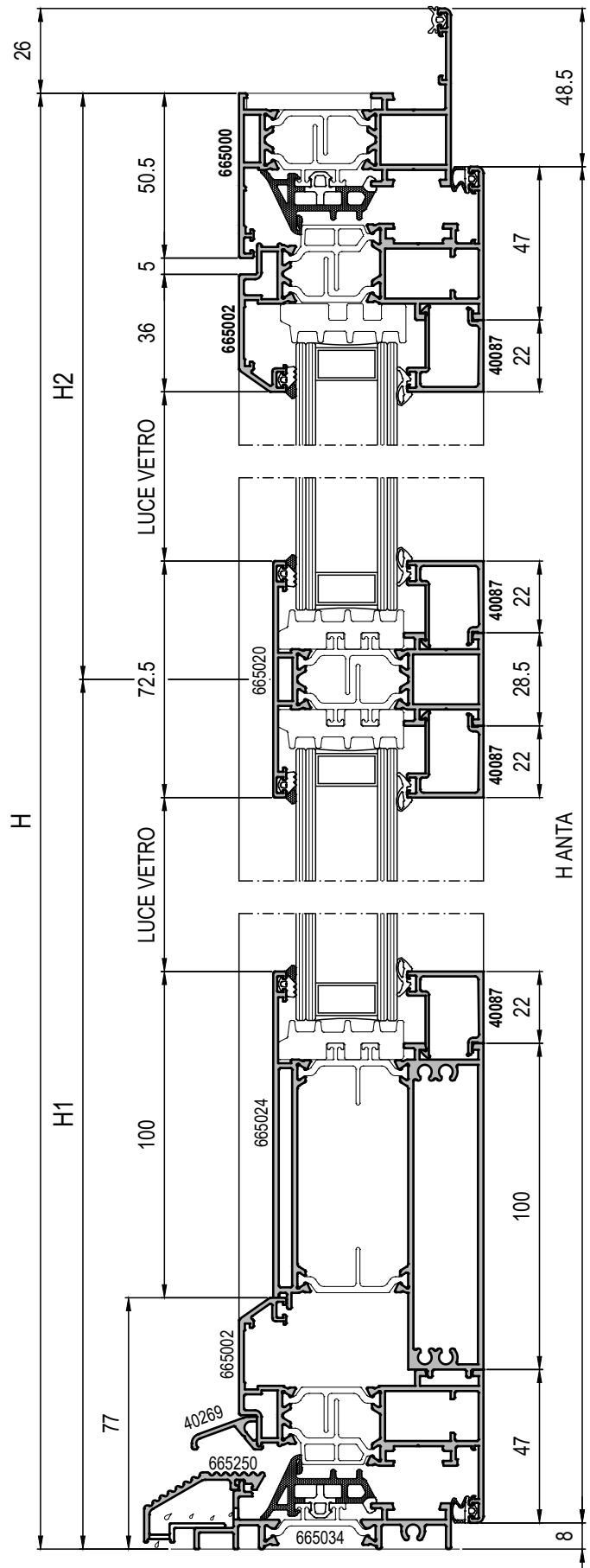
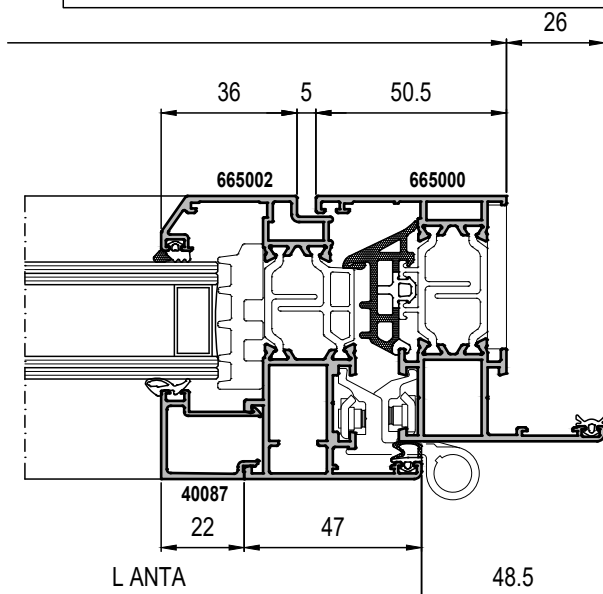

BILICO ORIZZONTALE DOPPIA BATTUTA

DISTINTI PROFILATI

| CODICE | PROFILATO | DESCRIZIONE | MISURA TAGLIO | TAGLIO | N° |
|--------|-----------|----------------------|----------------------------|--------|----------------------------|
| 665000 | | TELAIO Z | L + 52 | | 2 |
| | | | H + 52 | | 2 |
| 665019 | | INVERSIONE BILICO | L - 45 | | 1 |
| | | | H / 2 - 22.5 | | 1 |
| | | | H / 2 - 22.5 | | 1 |
| | | | L - 45 | | 2 |
| | | | H / 2 - 22.5 | | 1 |
| | | | H / 2 - 22.5 | | 1 |
| 665016 | | ANTA BILICO T | L - 111 | | 2 |
| | | | H - 111 | | 2 |
| 40087 | | FERMAVETRO | L - 264 | | 2 |
| | | | H - 308 | | 2 |
| 6405 | | ASTINA DI COMANDO | VEDI PAGINE LAVORAZIONI | | VEDI PAGINE LAVORAZIONI |

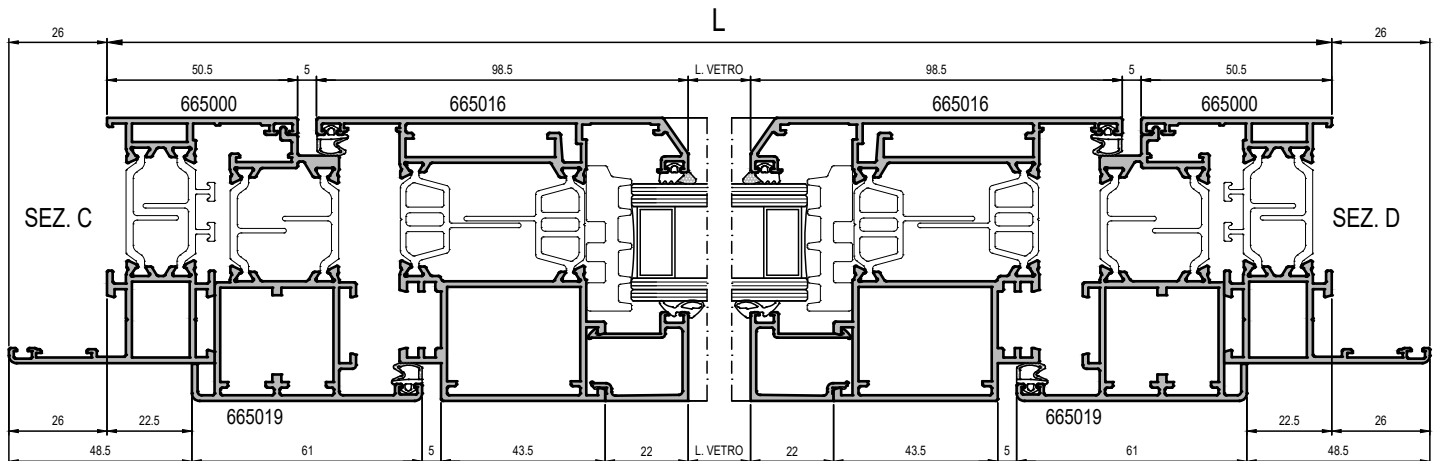
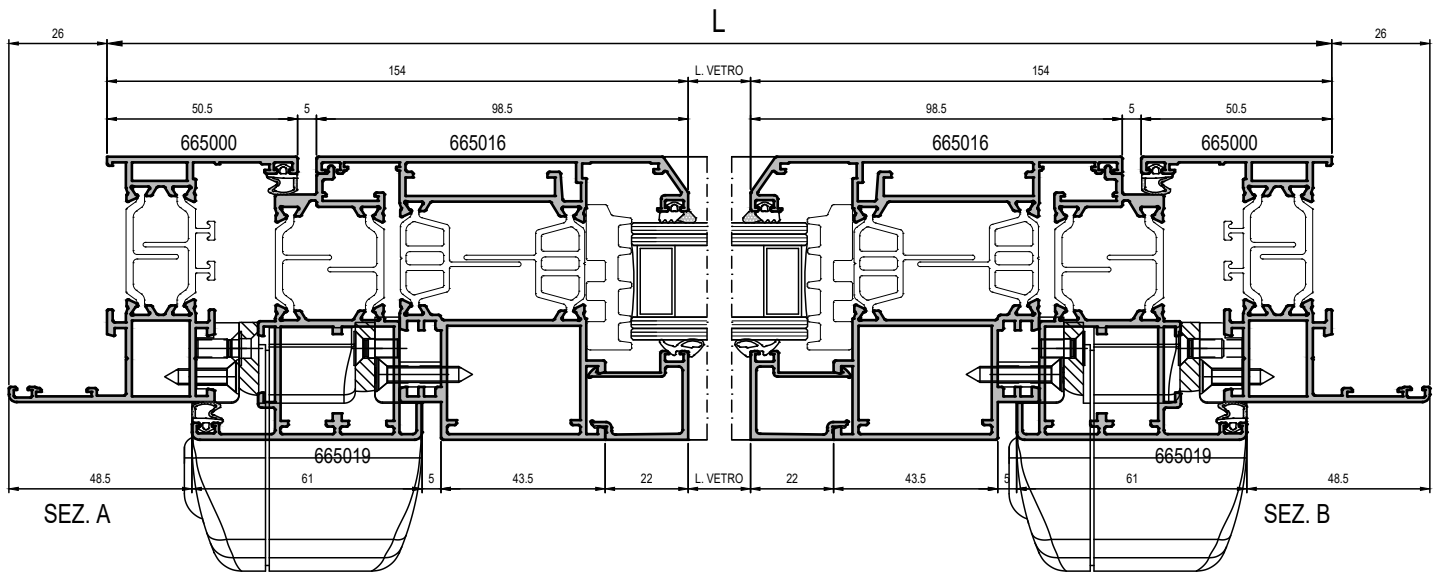
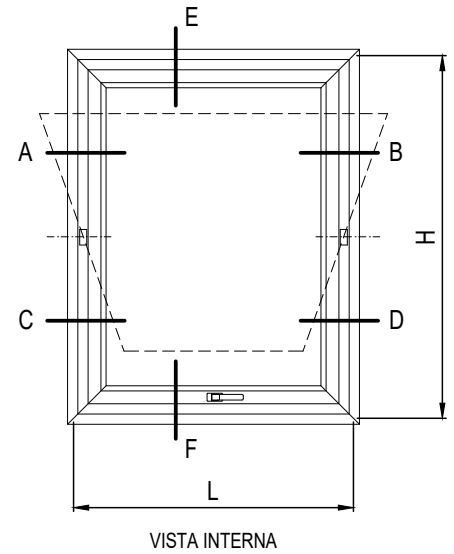

DISTINTA ACCESSORI

| CODICE | DESCRIZIONE | N° |
|------------------|---|---------|
| TA075 | REGOLO TELAIO CAMERA SEMPLICE | TABELLA |
| G2001 | VITE PER SQUADRETTA TS078 TS002 G2007 | 16 |
| G2002 * | SPINA PER SQUADRETTA TS078 TS002 G2007 | |
| TS078 | SQUADRETTA AD ESPANSIONE PER TUBOLARI STANDARD | 4 |
| TS077 * | SQUADRETTA A PULSANTE CON DADO | |
| G2007 | SQUADRETTA MAGGIORATA A PULSANTE | 4 |
| TS002 | SQUADRETTA AD ESPANSIONE PER RIPORTO 665019 | 4 |
| TS079 | SQUADRETTA ESTERNA A CIANFRINARE 4.9 x 14.6 | 4 |
| TS081 | SQUADRETTA ESTERNA A CIANFRINARE 4.9 x 39.6 | 4 |
| G501N | SQUADRETTA A CAMME PER TELAI | 8 |
| G269 | SQUADRETTA DI ALLINEAMENTO | 12 |
| G112 | SQUADRETTA INOX DI ALLINEAMENTO ANGOLI | 20 |
| TA060 | FRIZIONI PER BILICO | 1 |
| G196 | PIASTRE FISSAGGIO FRIZIONI PER BILICO | 1 |
| TA062 | KIT PER BILICO A 4 PUNTI PER MARTELLINA (NON INCLUSA) | 1 |
| G101 | CAPPETTA DRENAGGIO ACQUA | 2 ... 3 |
| * IN ALTERNATIVA | | |

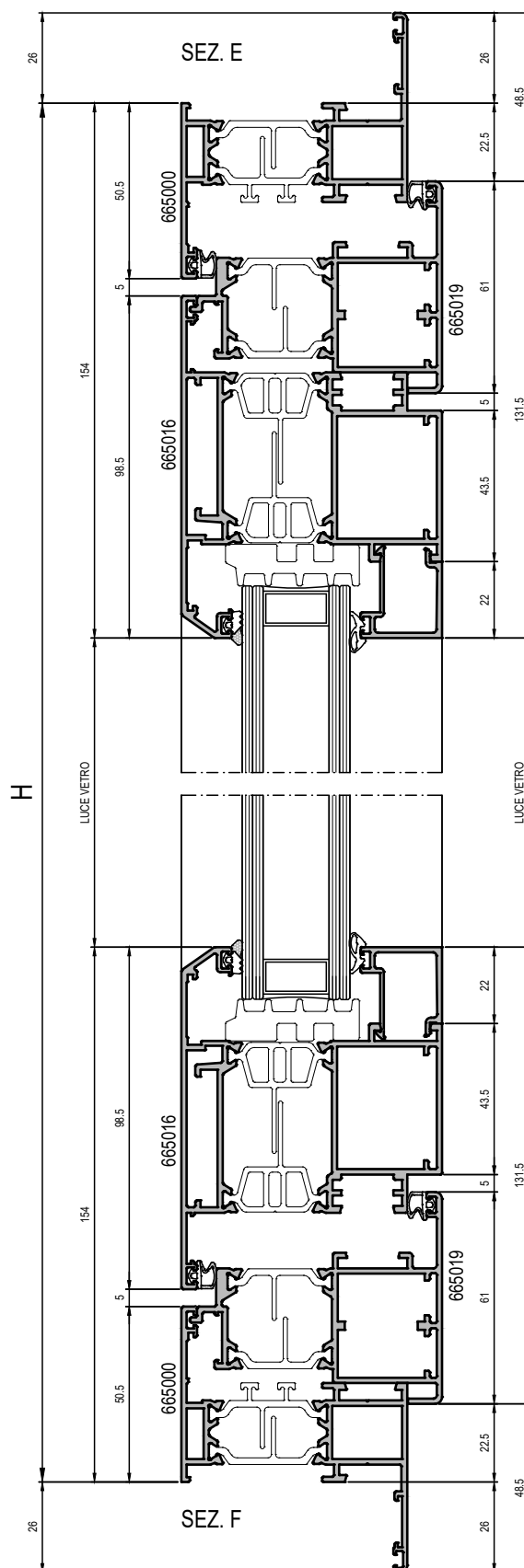

DISTINTA GUARNIZIONI

| CODICE | DESCRIZIONE | N° |
|------------------|--------------------------------|---------|
| TG031 | GUARNIZIONE DI BATTUTA | 4L + 4H |
| TG300 | SOTTOVETRO ISOLANTE | 2L + 2H |
| TG032 | GUARNIZIONE CINGIVETRO ESTERNA | 2L + 2H |
| | GUARNIZIONE CINGIVETRO INTERNA | 2L + 2H |
| * IN ALTERNATIVA | | |



FINESTRA A DUE ANTE GIUNTO APERTO APERTURA INTERNA CENTRALE TZ

DISTINTA PROFILATI

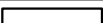
| CODICE | PROFILATO | DESCRIZIONE | MISURA TAGLIO | TAGLIO | N° |
|---------|---|-------------------|----------------------------------|---|----------------------------------|
| 665000 |  | TELAIO Z | L + 52 |  | 1 |
| | | | H + 52 |  | 2 |
| 665001 |  | TELAIO L | L |  | 1 |
| 665002 |  | ANTA Z | L/2 - 13.2 |  | 4 |
| | | | H - 45 |  | 3 |
| 665011 |  | ANTA T | H - 26.4 |  | 1 |
| 40087 |  | FERMAVETRO | L/2 - 107.2 |  | 4 |
| | | | H - 183 |  | 4 |
| 40081 * |  | FERMAVETRO | L/2 - 151.2 |  | 4 |
| | | | H - 183 |  | 4 |
| 6405 |  | ASTINA DI COMANDO | DIPENDE DA ACCESSORIO DI COMANDO |  | DIPENDE DA ACCESSORIO DI COMANDO |

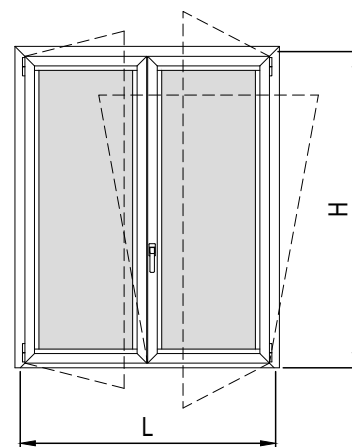

VISTA INTERNA

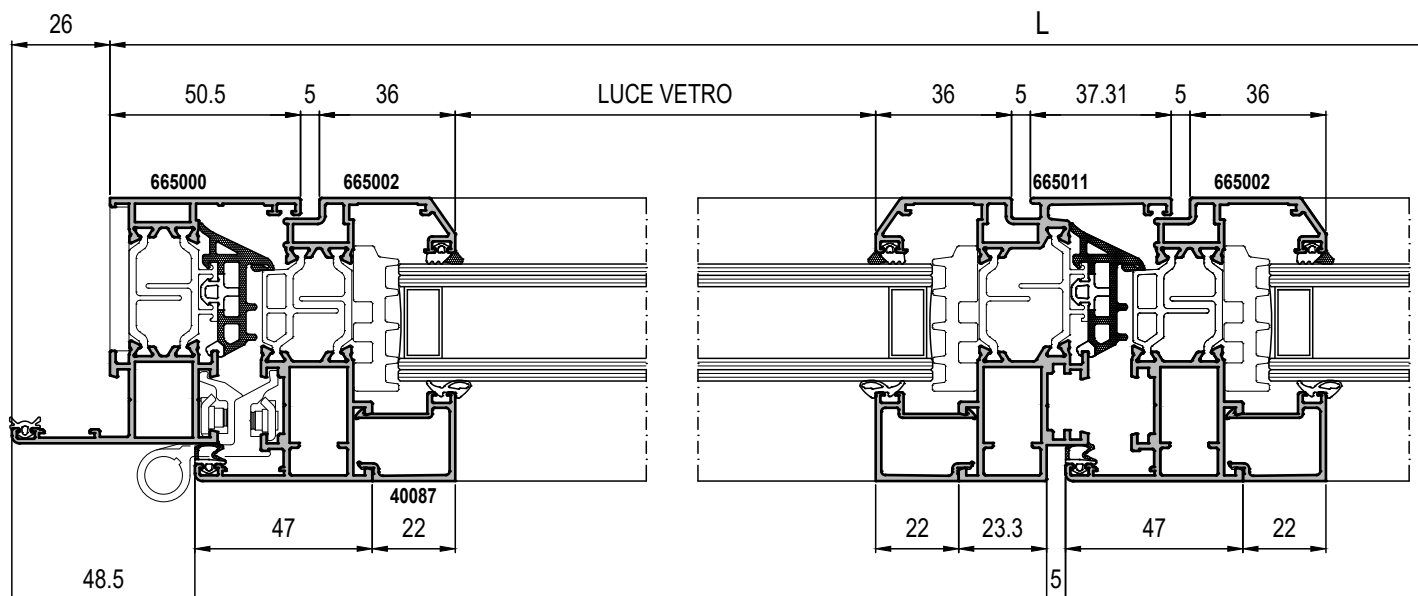

DISTINTA ACCESSORI

| CODICE | DESCRIZIONE | N° |
|------------------|---|---------|
| TA075 | REGOLO TELAIO CAMERA SEMPLICE | TABELLA |
| G2001 | VITE PER SQUADRETTA TS078 | 24 |
| G2002 * | SPINA PER SQUADRETTA TS078 | |
| TS077 | SQUADRETTA A PULSANTE PER TELAIO ED ANTA | 12 |
| TS078 * | SQUADRETTA A SPINARE-CIANFRINARE PER TELAIO ED ANTA | |
| G501N | SQUADRETTA A CAMME PER ANTE | 12 |
| TS079 | SQUADRETTA ANTA E TELAIO TUBOLARITÀ ESTERNA | 12 |
| S3001 | SPINA MM 3 PER SQUADRETTA TS079 | 24 |
| G112 | SQUADRETTA INOX DI ALLINEAMENTO ANGOLI | 4 |
| G268 | SQUADRETTA ALLINEAMENTO ANTE | 8 |
| G269 | SQUADRETTA ALLINEAMENTO TELAIO | 2 |
| TT065 | COPPIA TAPPI RIPORTO CENTRALE | 1 Cp. |
| G101 | CAPPETTA DI DRENAGGIO ACQUA | 2...4 |
| G231* | ANGOLO PRESSOFUSO PER FERMAVETRI ARROTONDATI | 8 |
| * IN ALTERNATIVA | | |

N.B. : PER GLI ACCESSORI DI CHIUSURA, MOVIMENTAZIONE E LIMITI PRESTAZIONALI CONSULTARE IL MANUALE DEL FORNITORE DEGLI ACCESSORI.

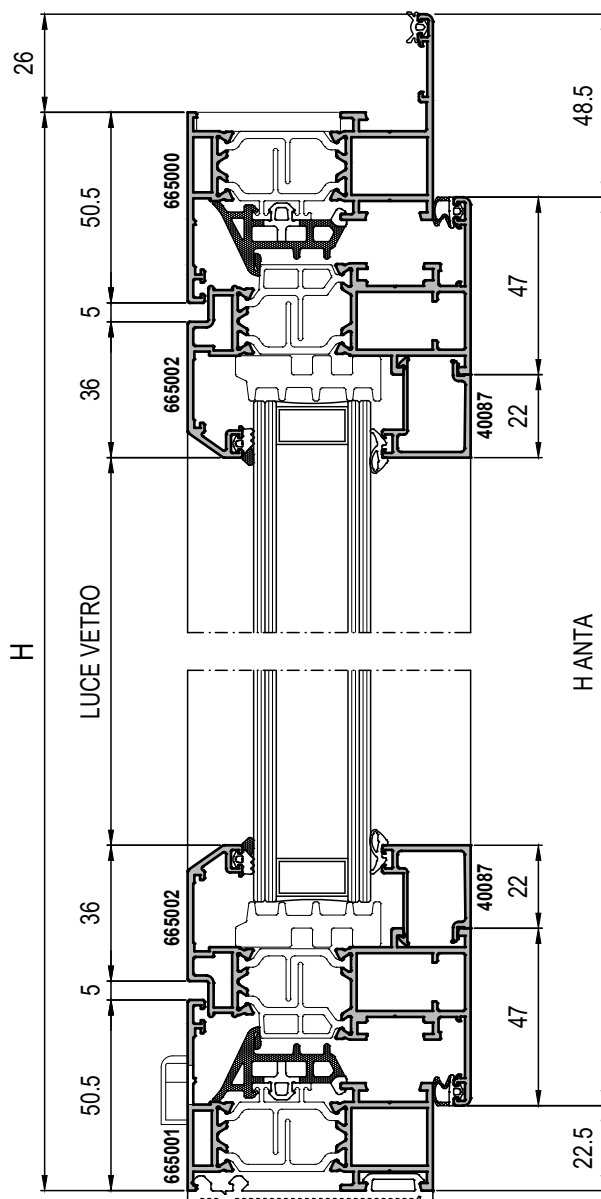
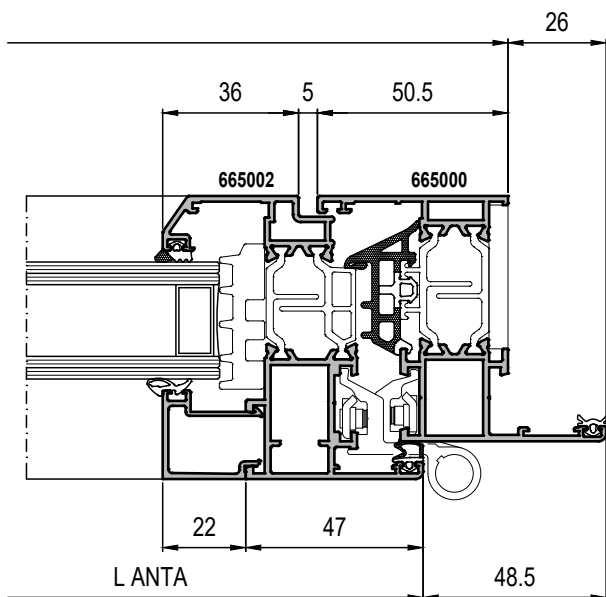

DISTINTA GUARNIZIONI

| CODICE | DESCRIZIONE | N° |
|------------------|----------------------------------|-------|
| TG176 | ANGOLO VULCANIZZATO | 4 Pz. |
| TG175 | GUARNIZIONE DI TENUTA CENTRALE | 2L+3H |
| TG031 | GUARNIZIONE DI BATTUTA | 2L+4H |
| | GUARNIZIONE CINGIVETRO ESTERNA | 2L+4H |
| | GUARNIZIONE CINGIVETRO INTERNA | 2L+4H |
| TG302 | GUARNIZIONE PERIMETRALE ISOLANTE | L |
| TG004 | GUARNIZIONE BATTUTA A MURO | L+2H |
| TG300 | SOTTOVETRO ISOLANTE | 2L+4H |
| Z119 | GUARNIZIONE ISOLANTE | L+2H |
| * IN ALTERNATIVA | | |



Nodi Scala 1:1 

FISSO

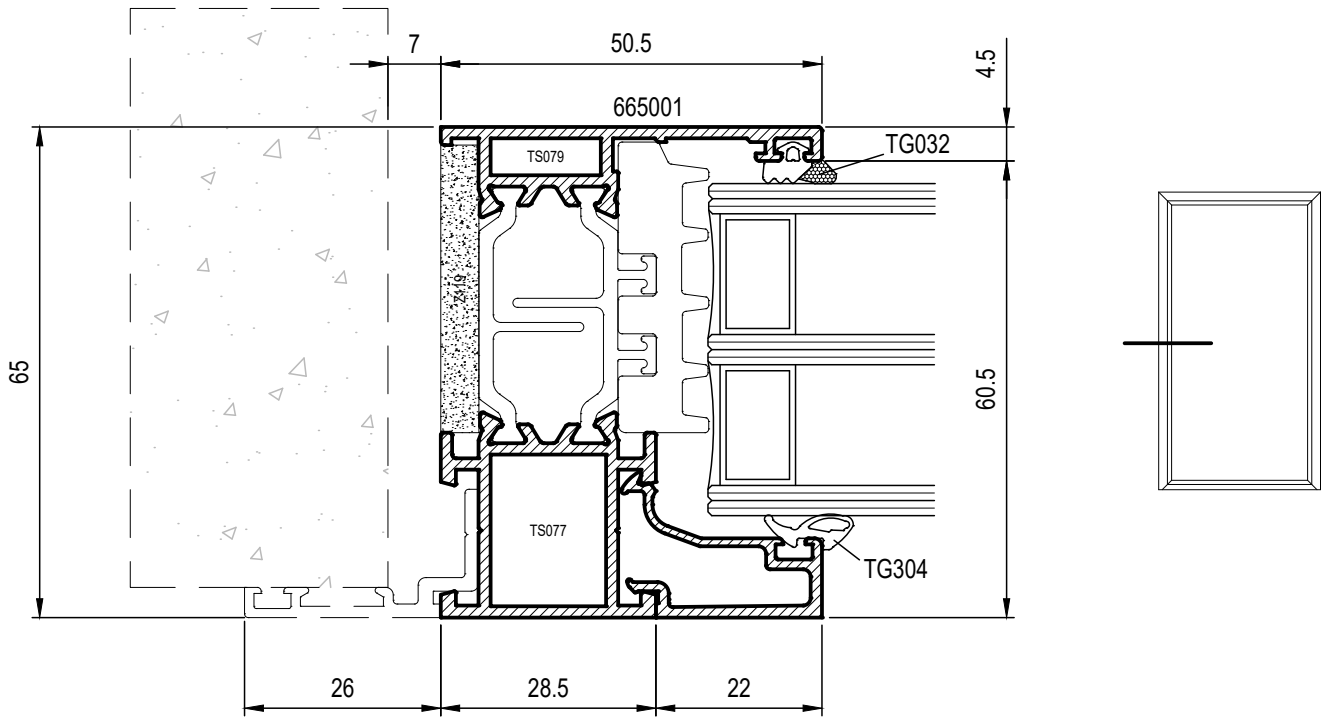

APERTURA INTERNA

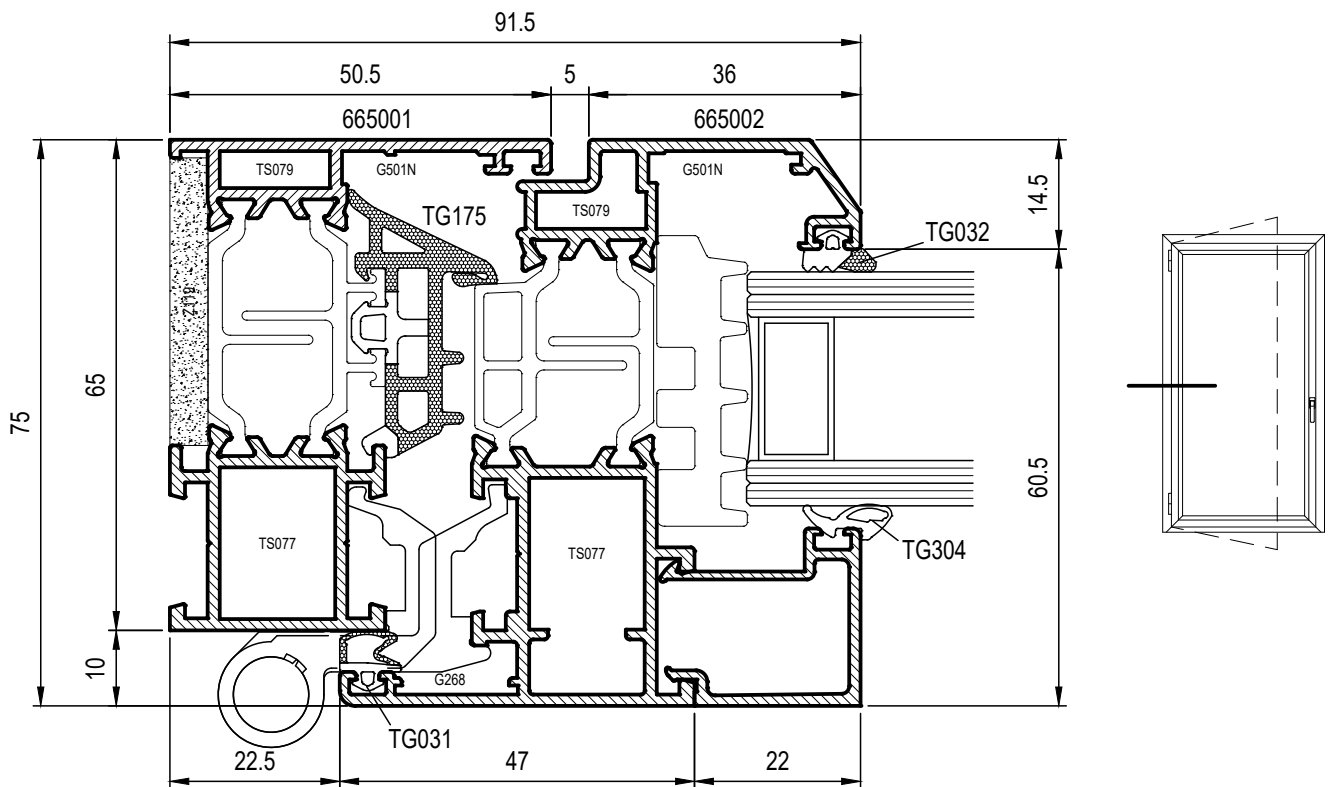

DUE ANTE SOLUZIONE Z - RIPORTO - Z

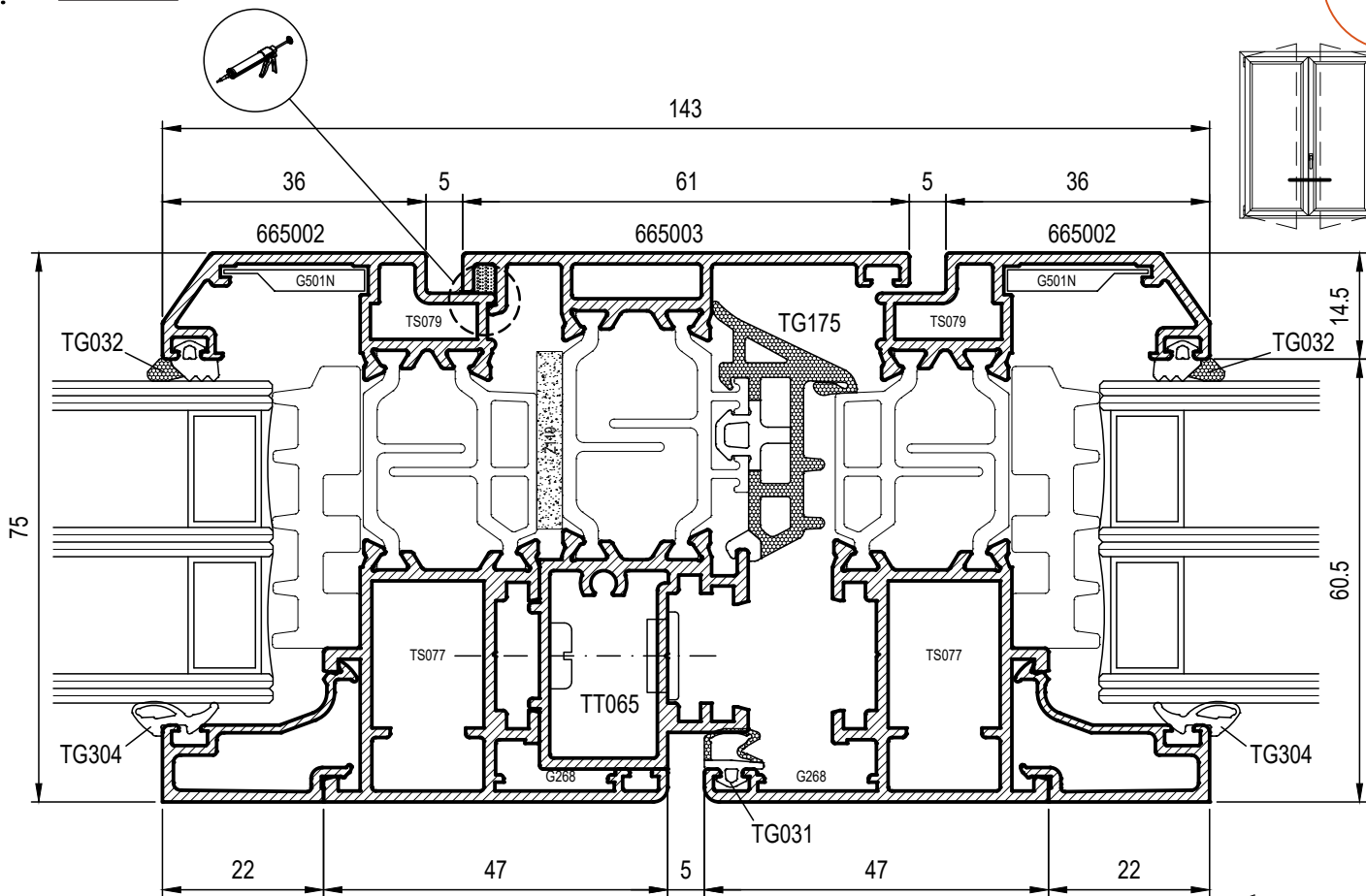

TERZA ANTA
SOLUZIONE Z - RIPORTO - Z

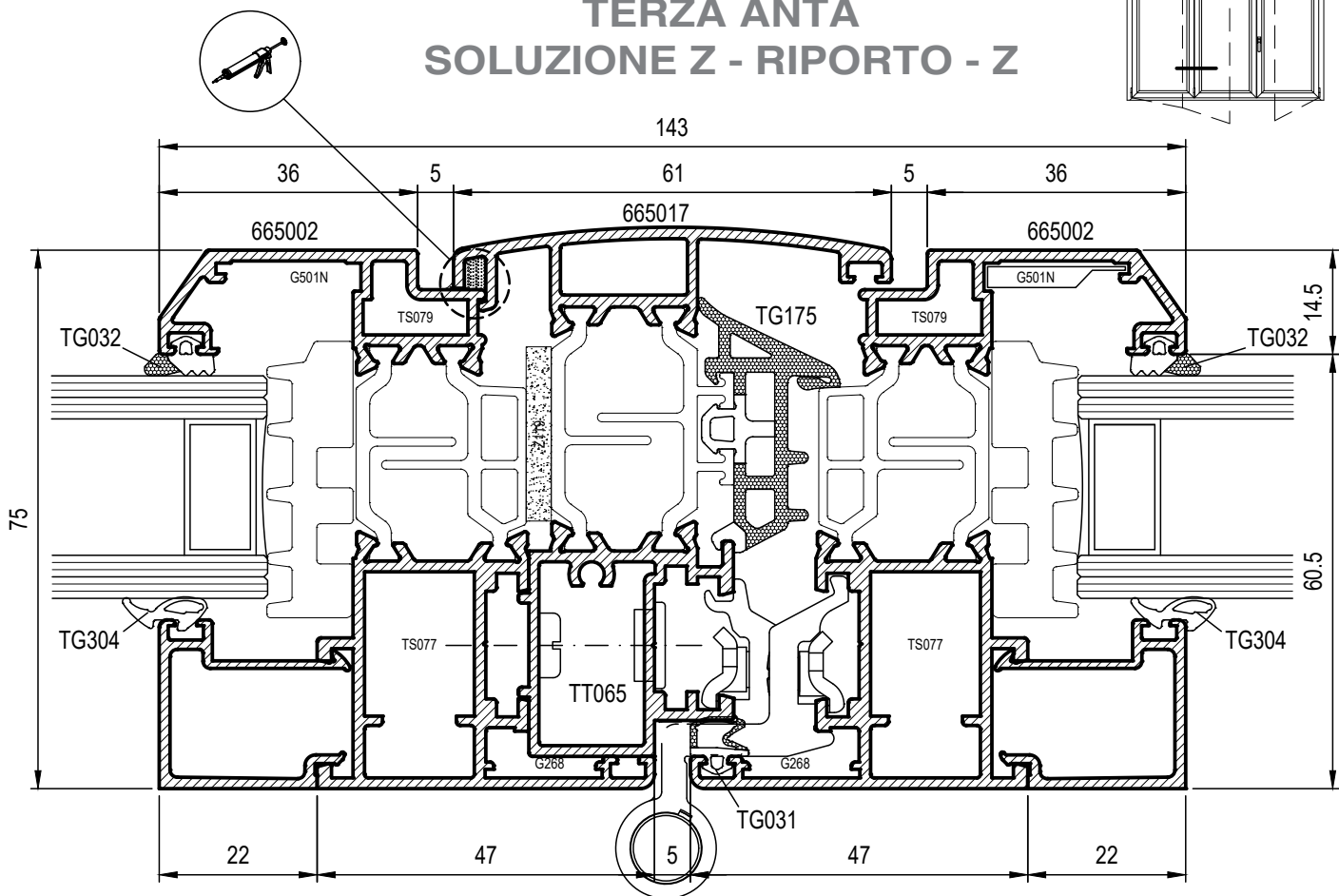

DUE ANTE SOLUZIONE T - Z

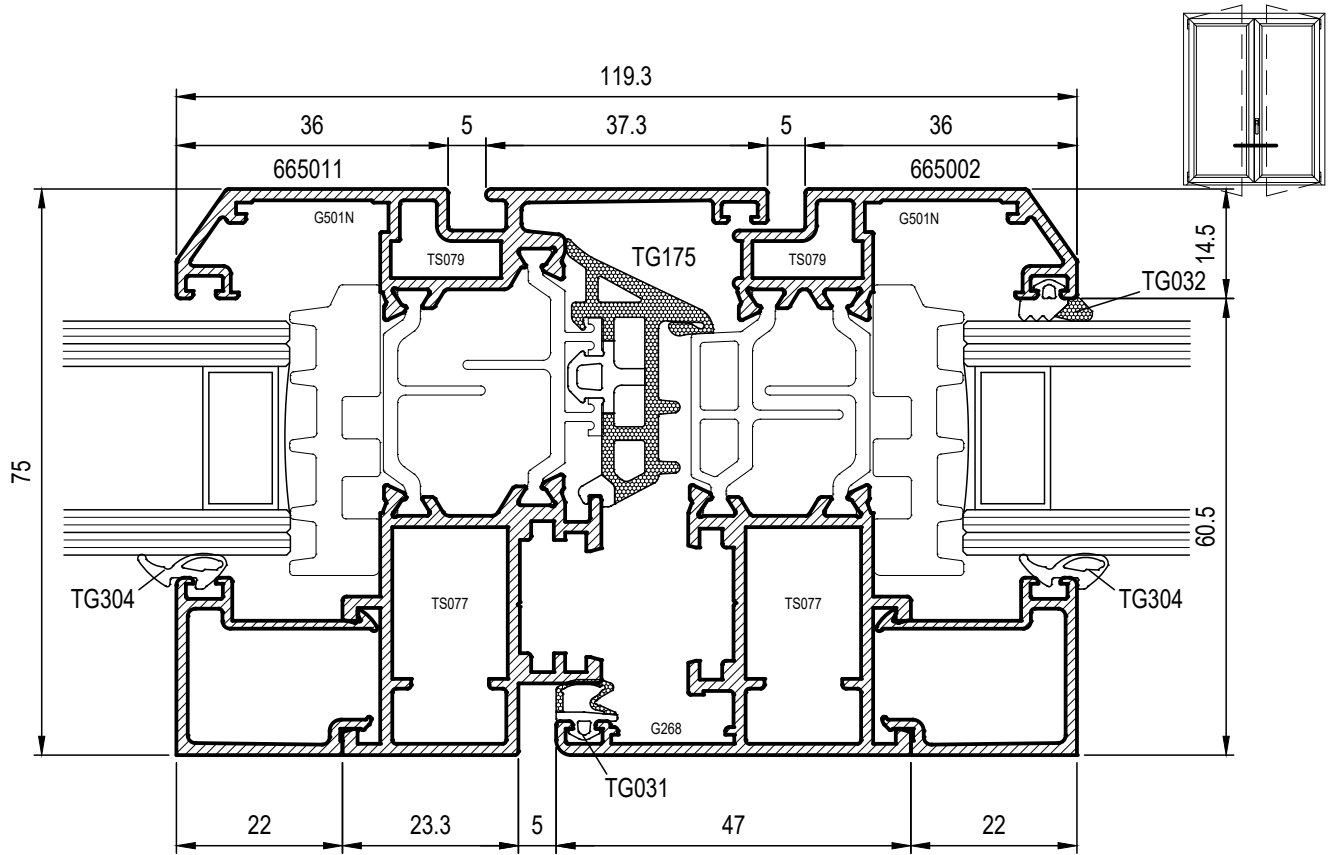

TERZA ANTA SOLUZIONE T - Z

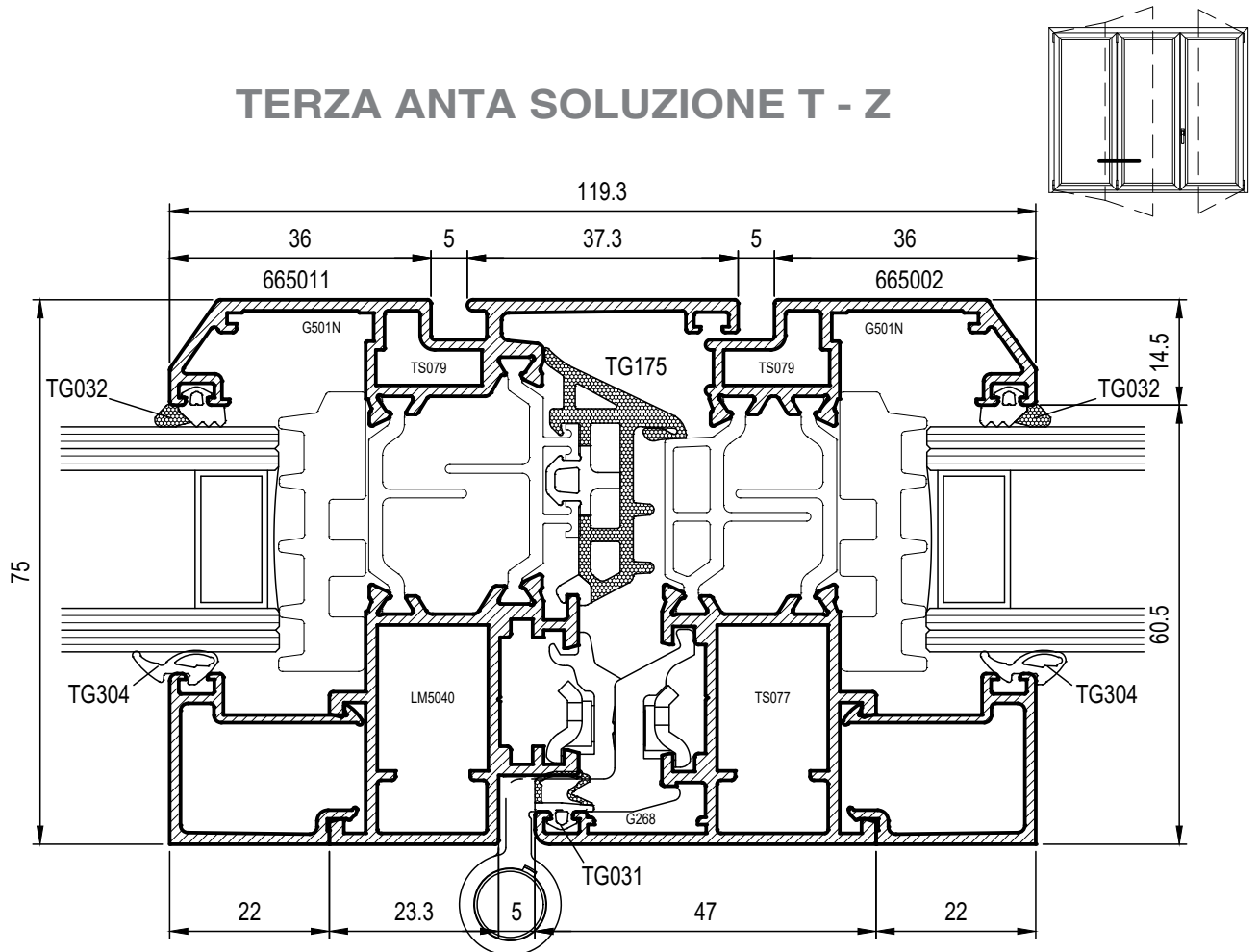

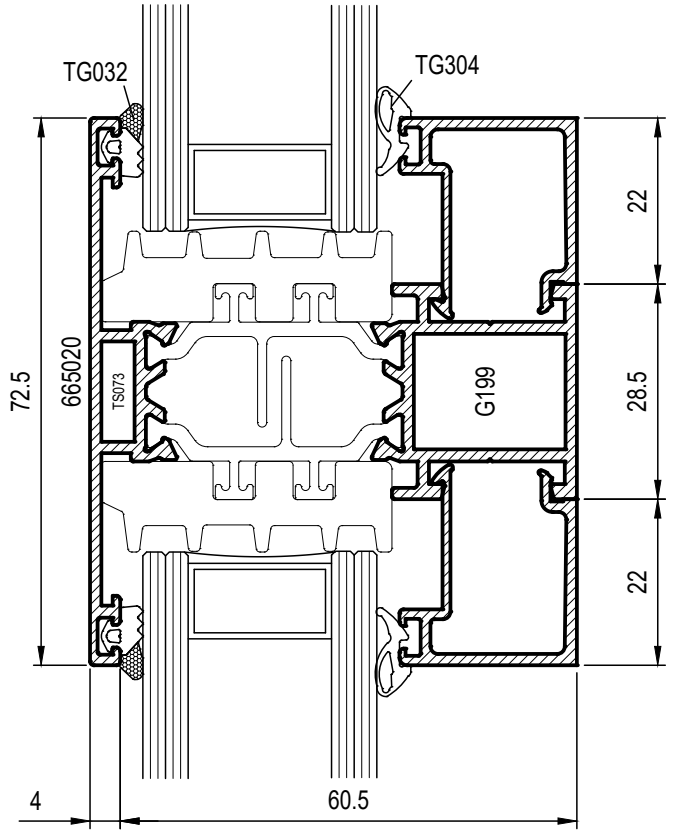
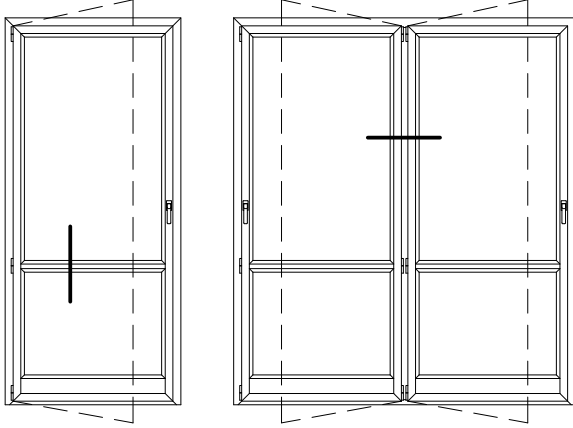

APRIBILI AFFIANCATI

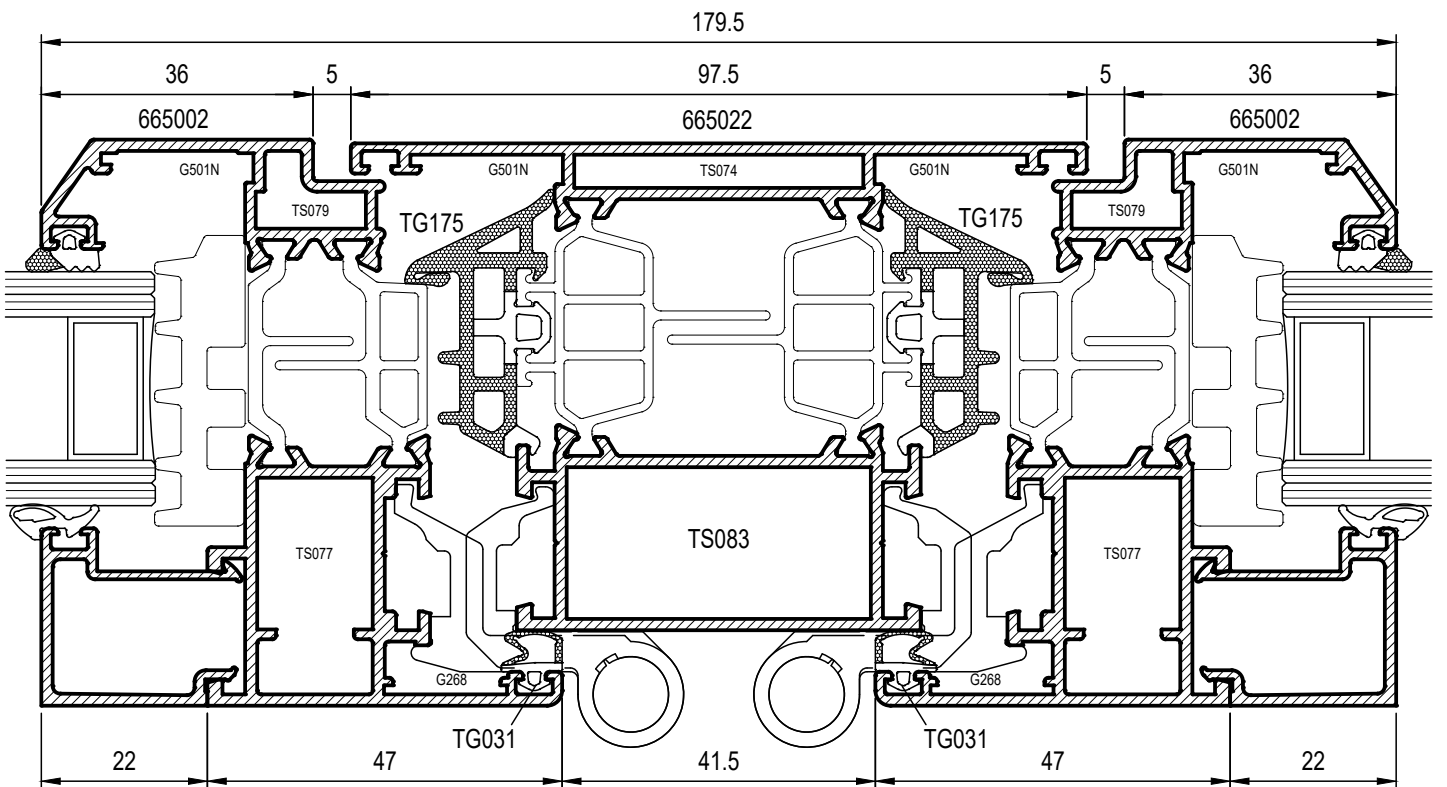

Nodi Scala 1:1



ZOCCOLO RIPORTATO PORTABALCONE

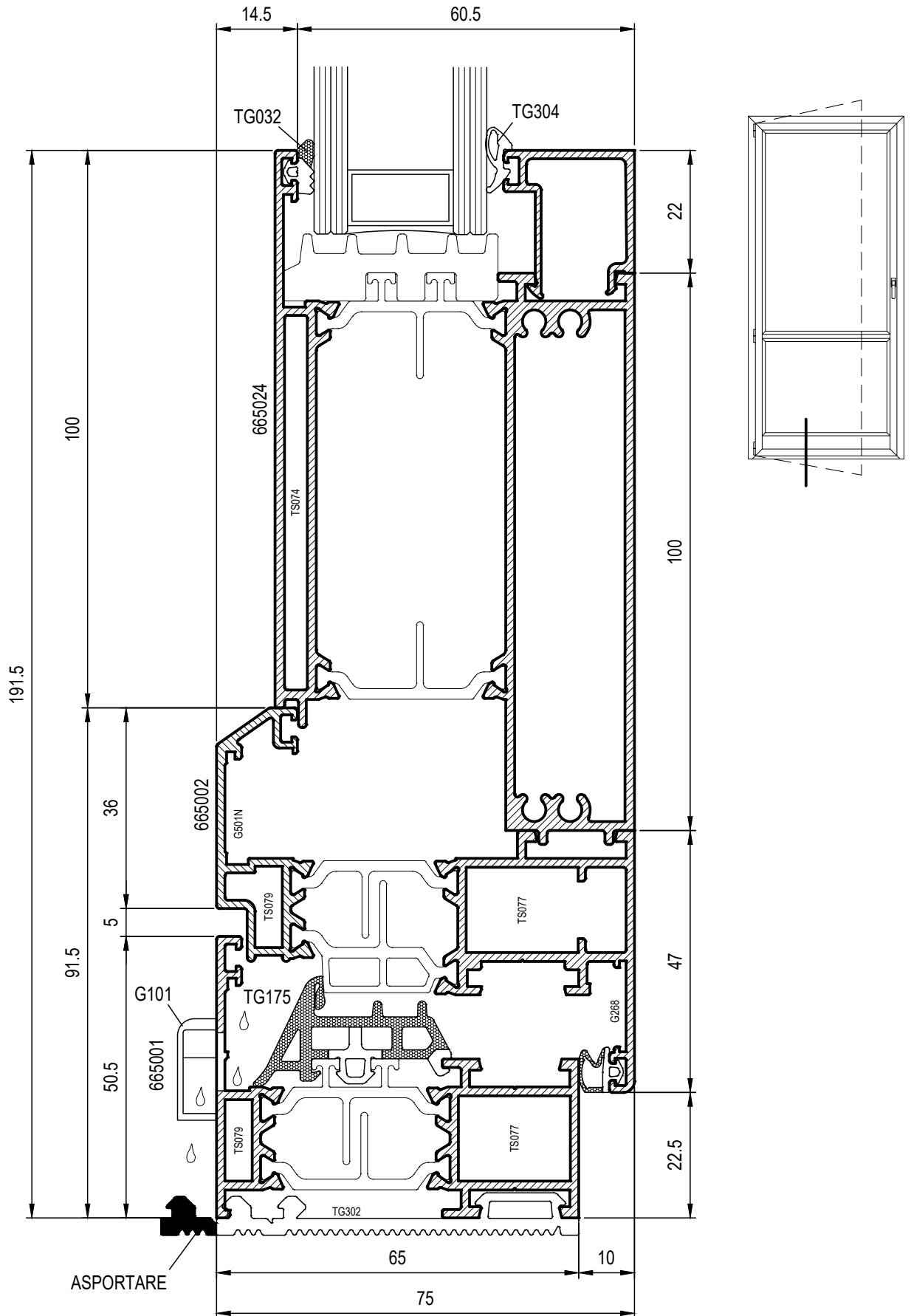

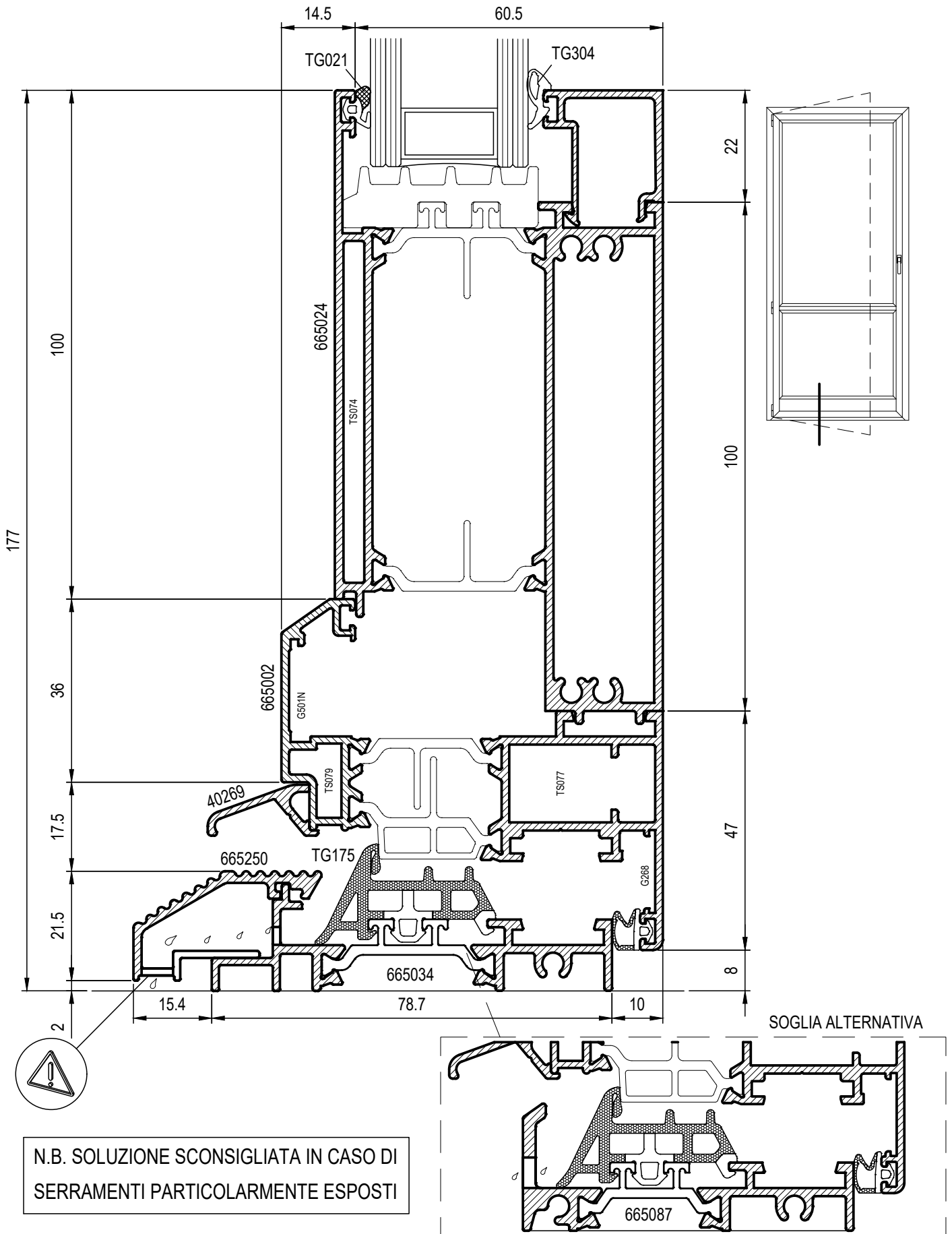

N.B. SOLUZIONE SCONSIGLIATA IN CASO DI SERRAMENTI PARTICOLARMENTE ESPOSTI

SOGLIA ALTERNATIVA

Nodi Scala 1:1



APERTURA INTERNA CON ANTA VETRO A INFILO

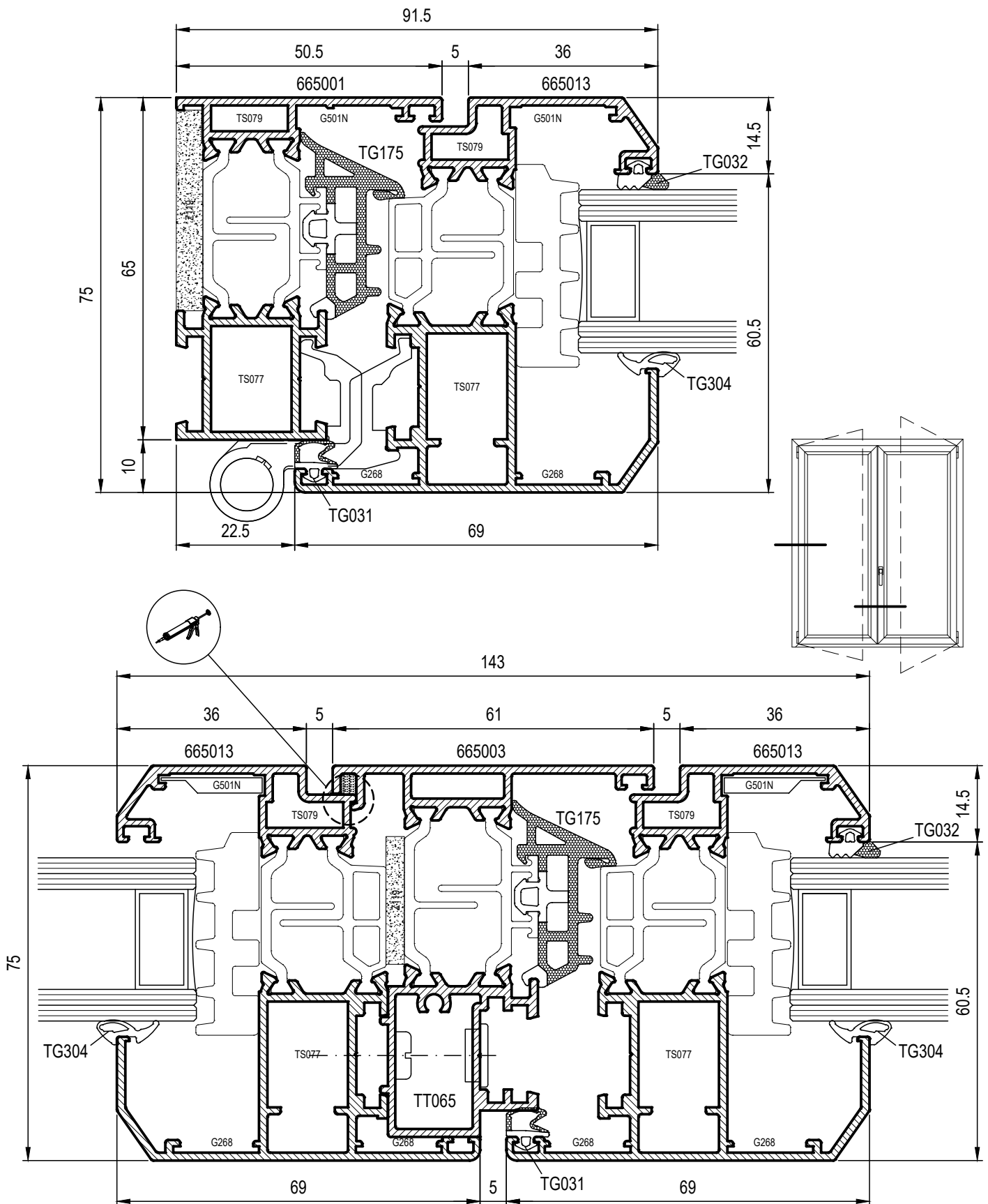

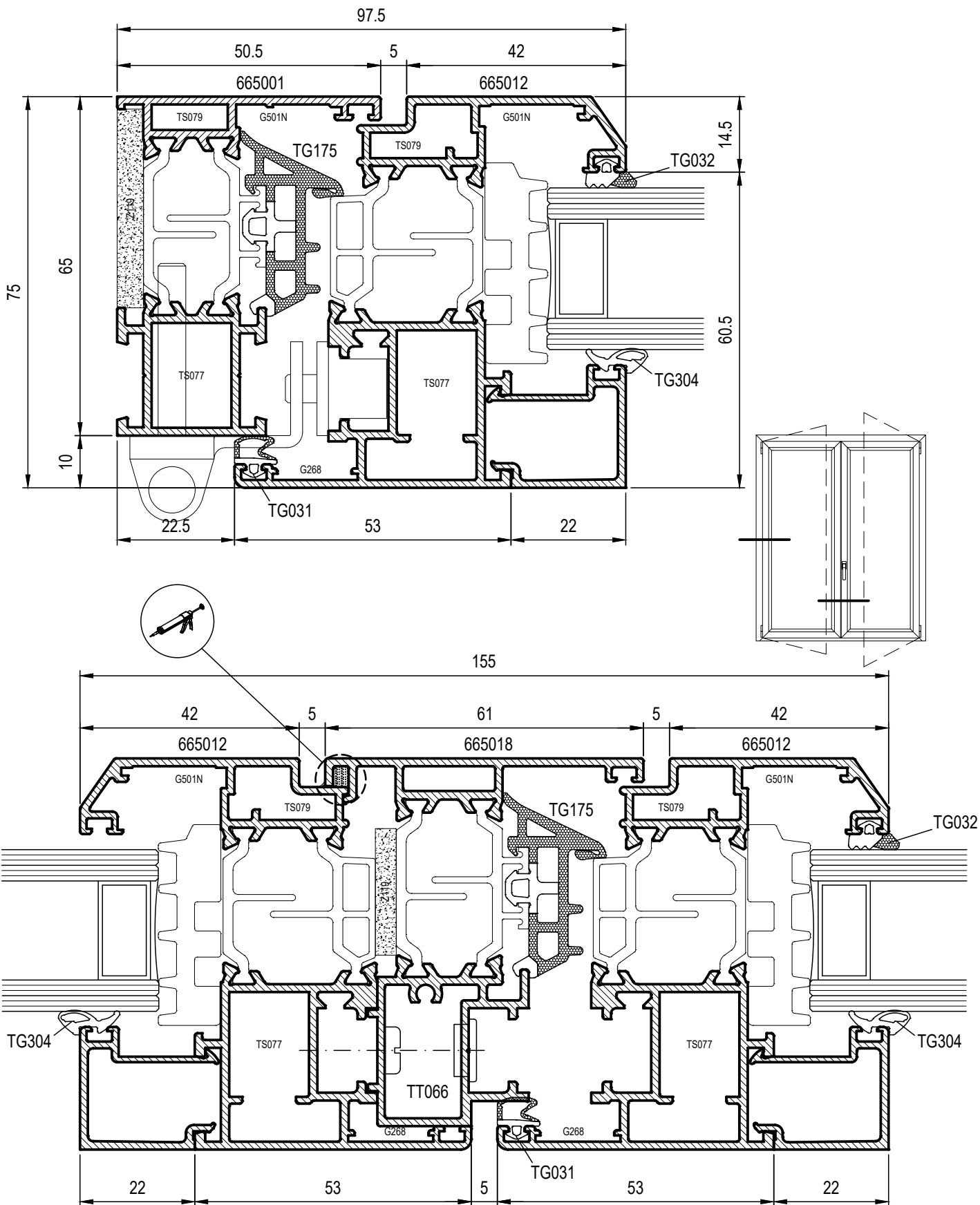

Nodi Scala 1:1

APERTURA INTERNA CON ANTA PIANA

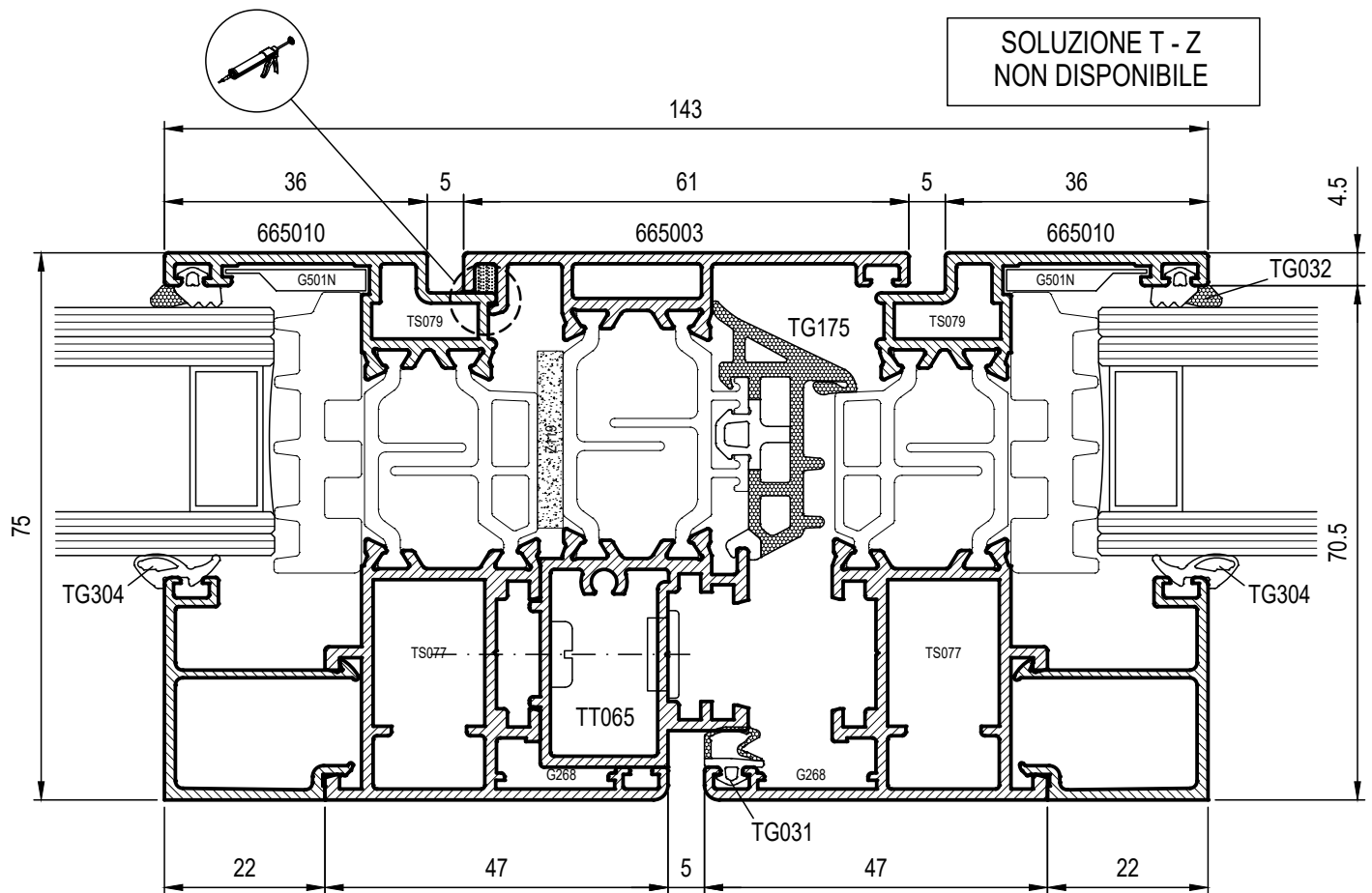
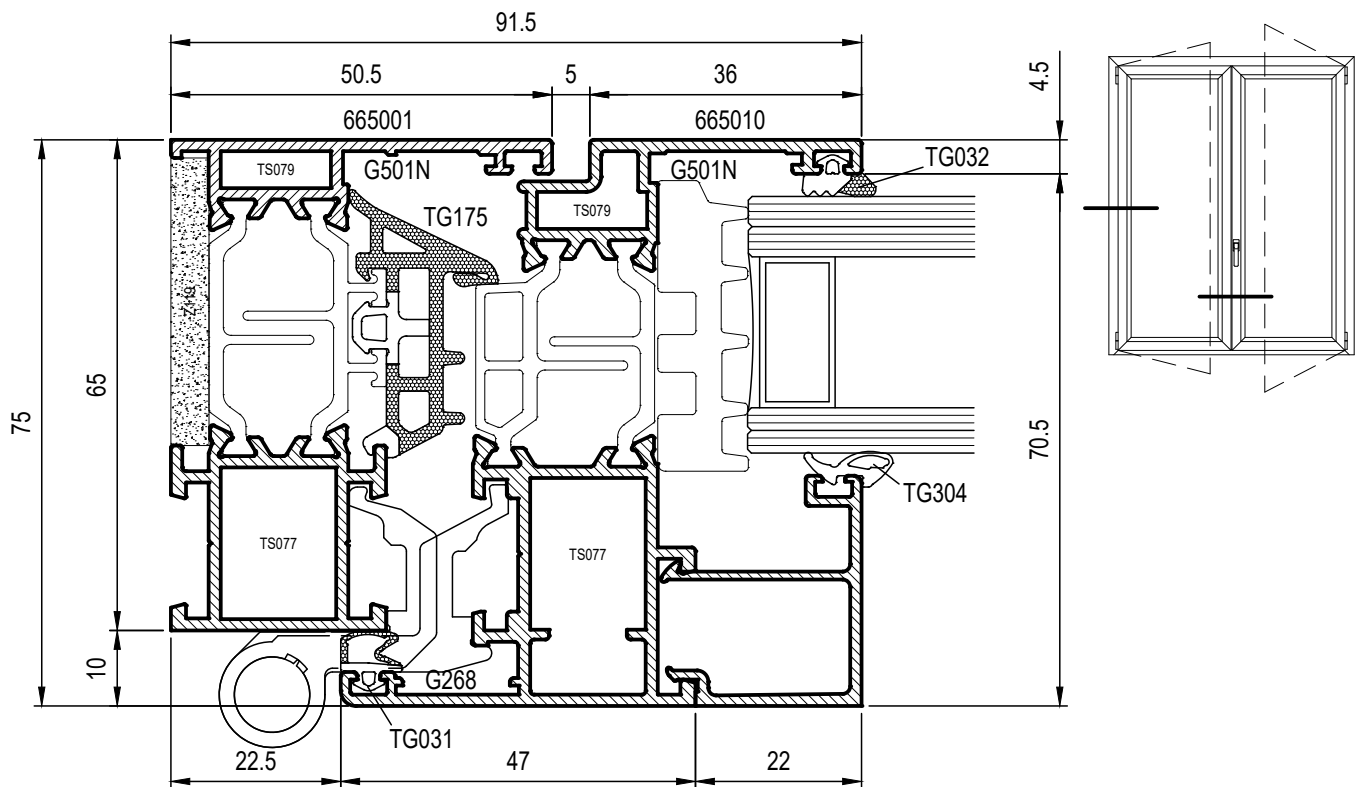

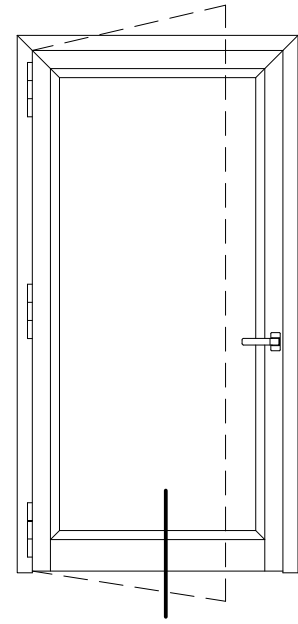
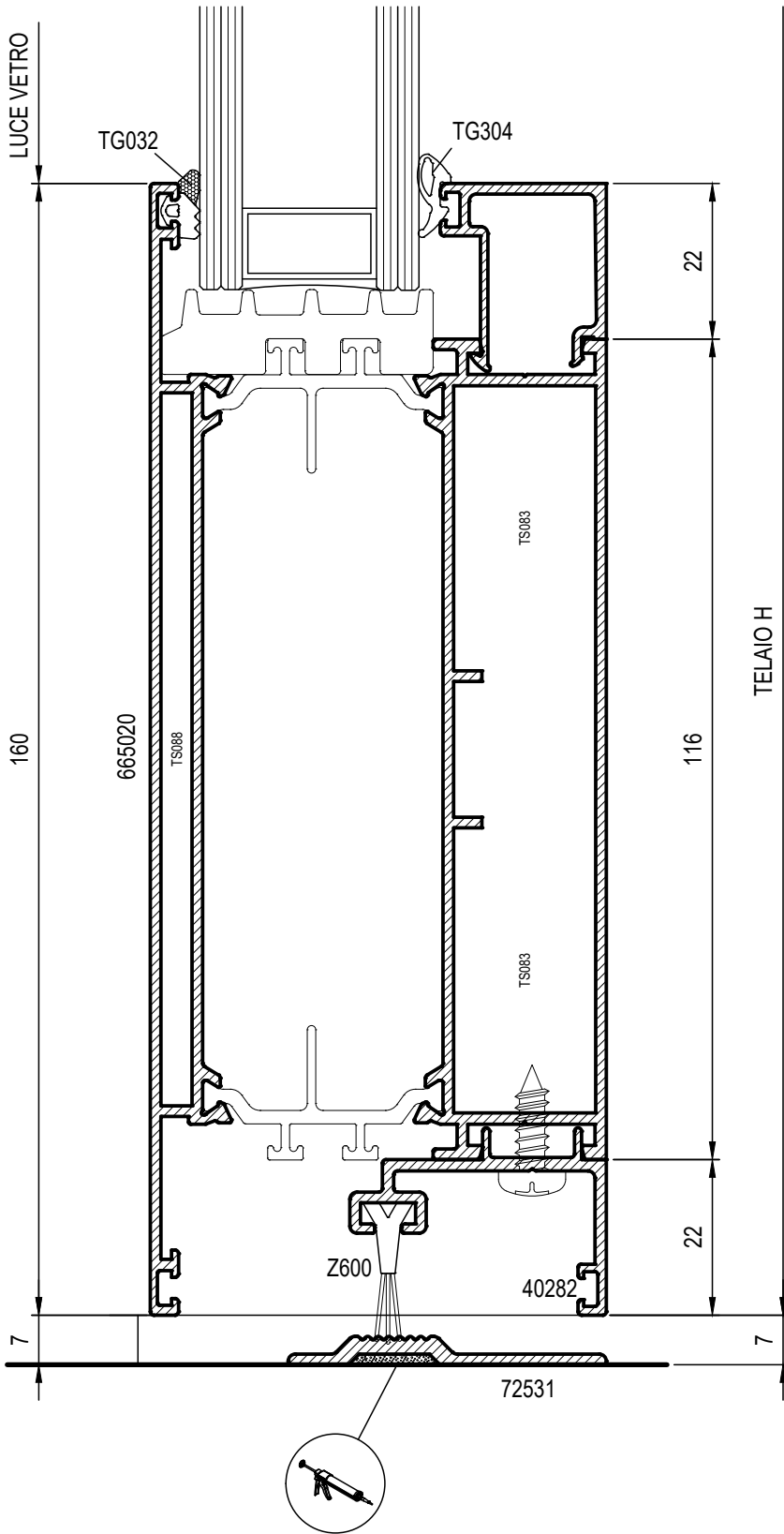

ZOCCOLO

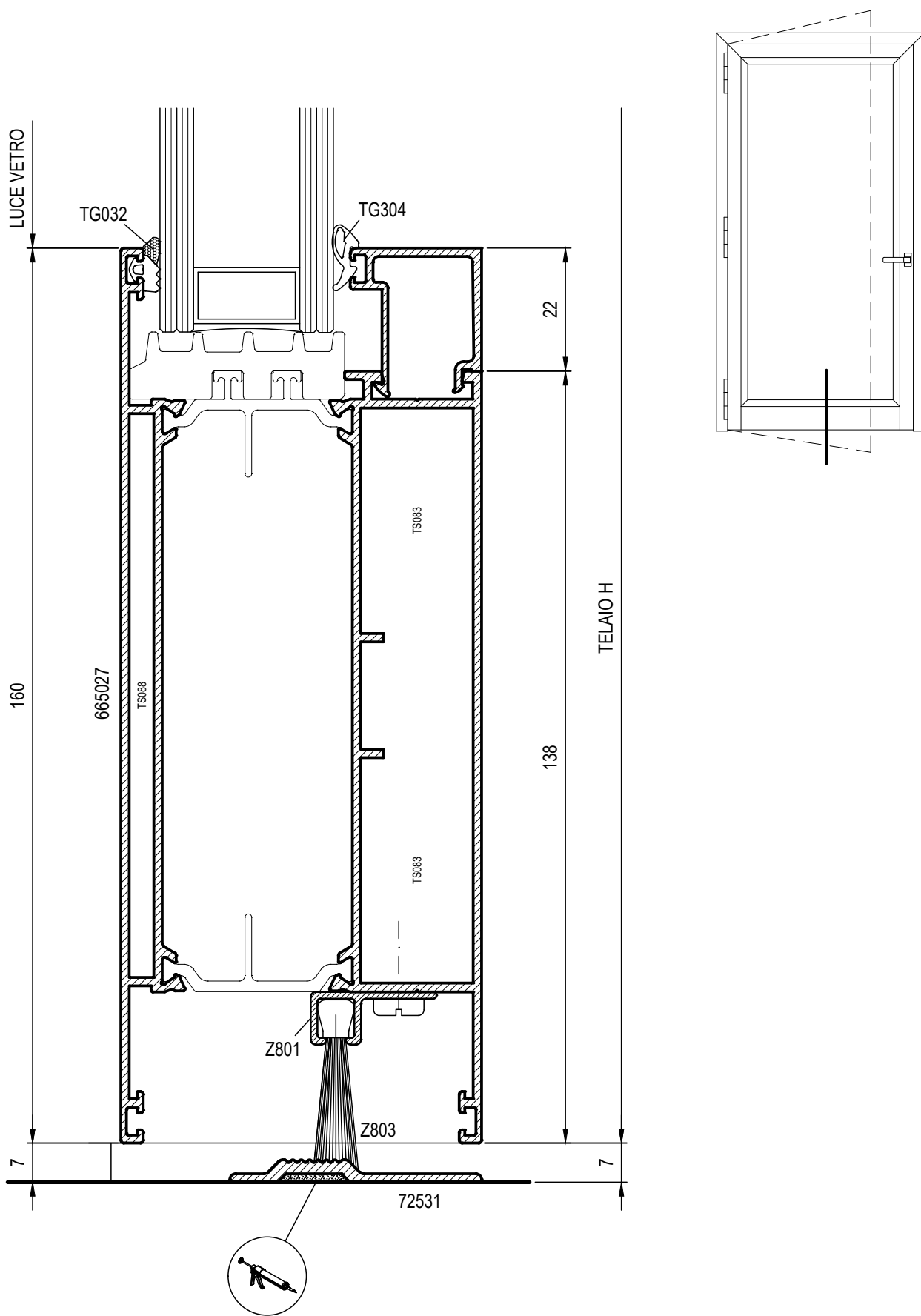

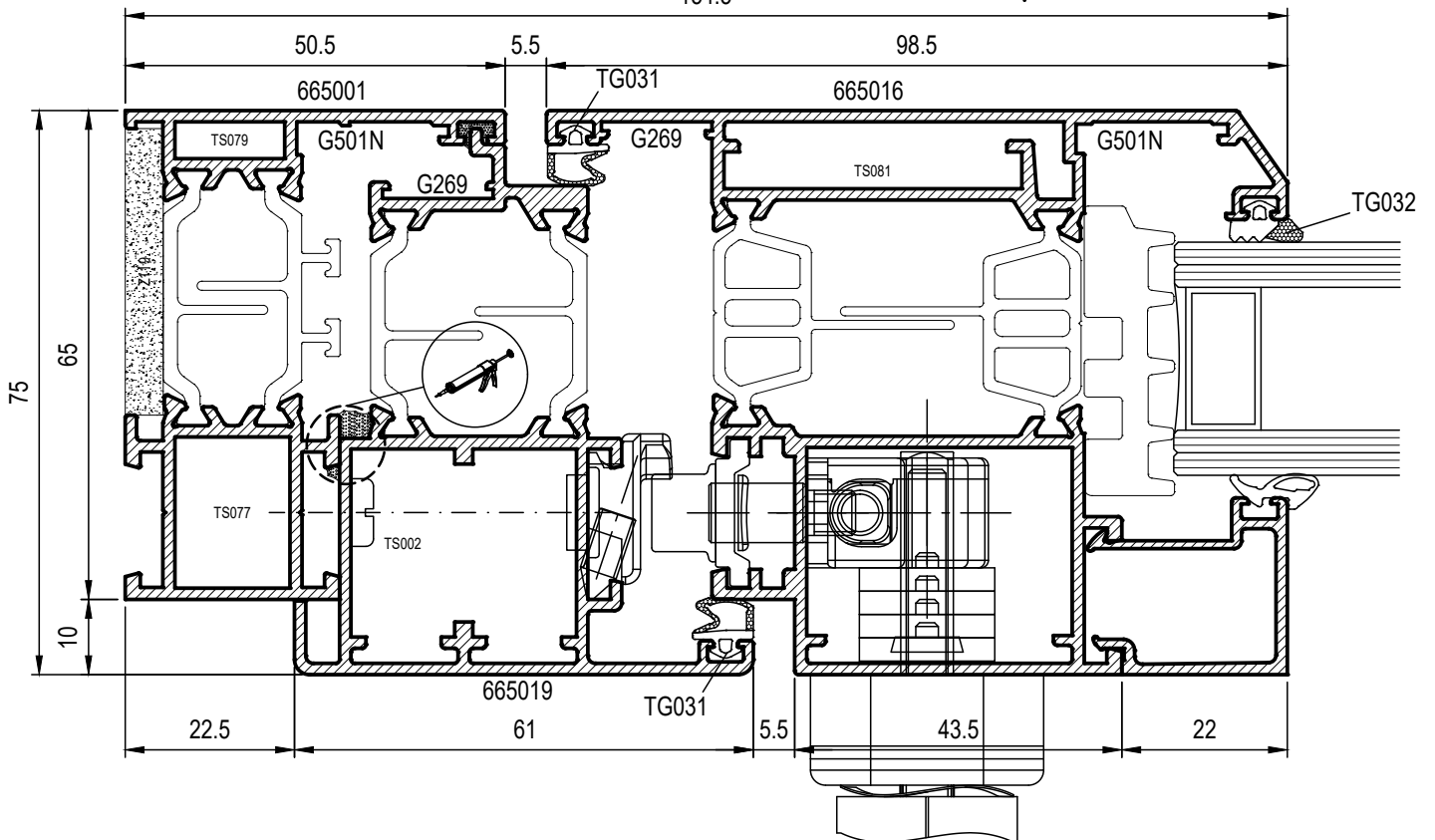
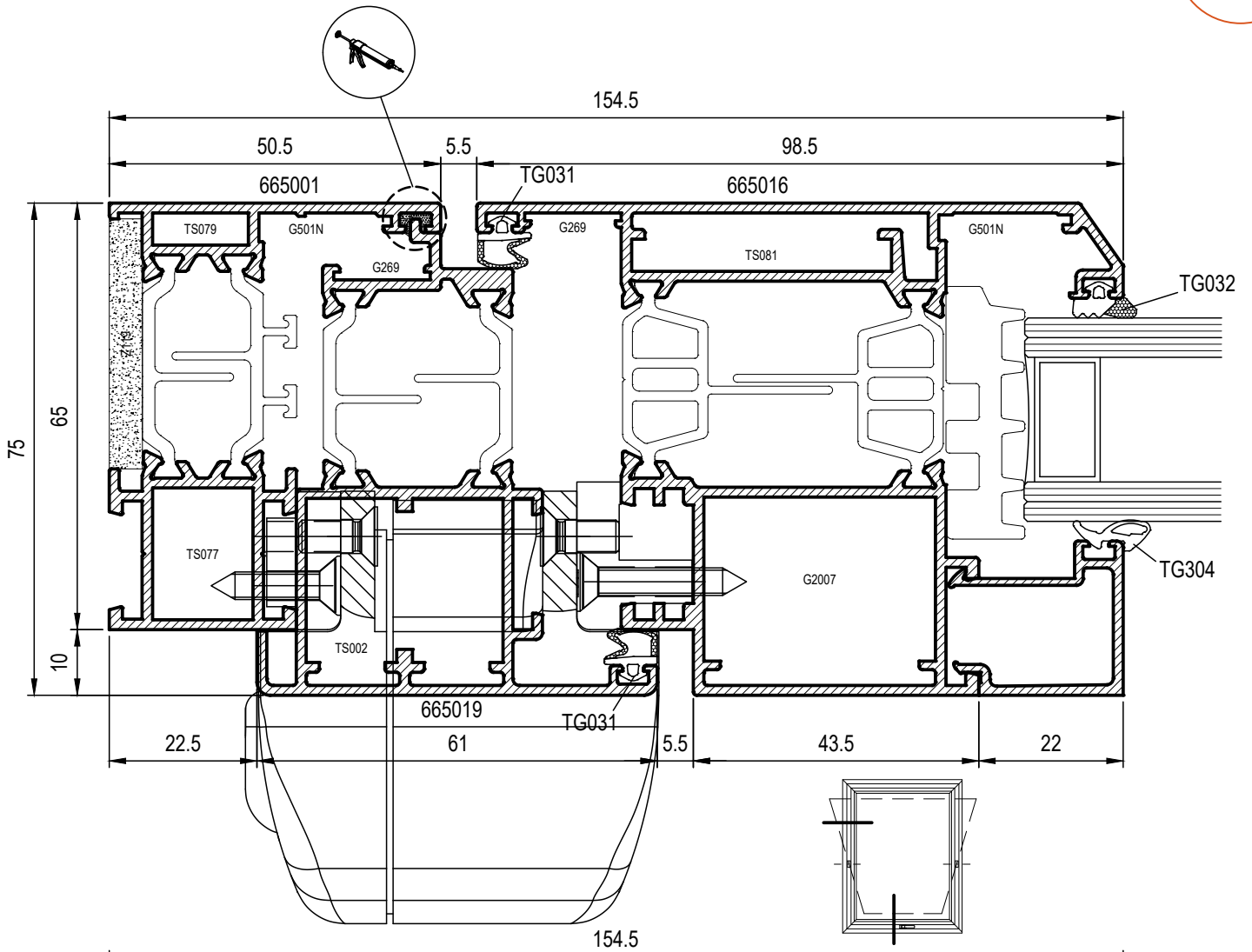

BILICO CHIUSURA CON CREMONESE

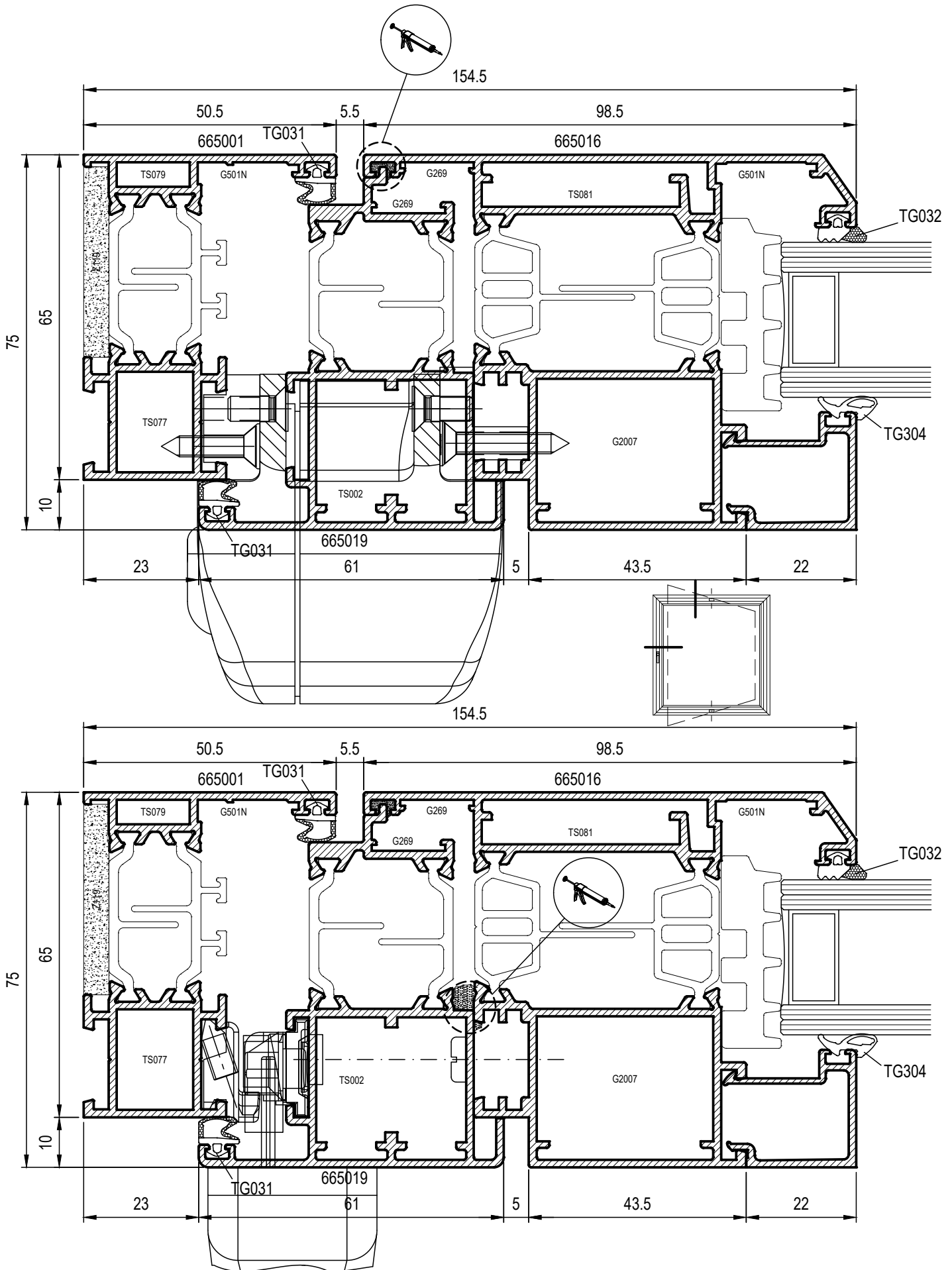

MONOBLOCCO CON SPALLA A PROFILATO UNICO

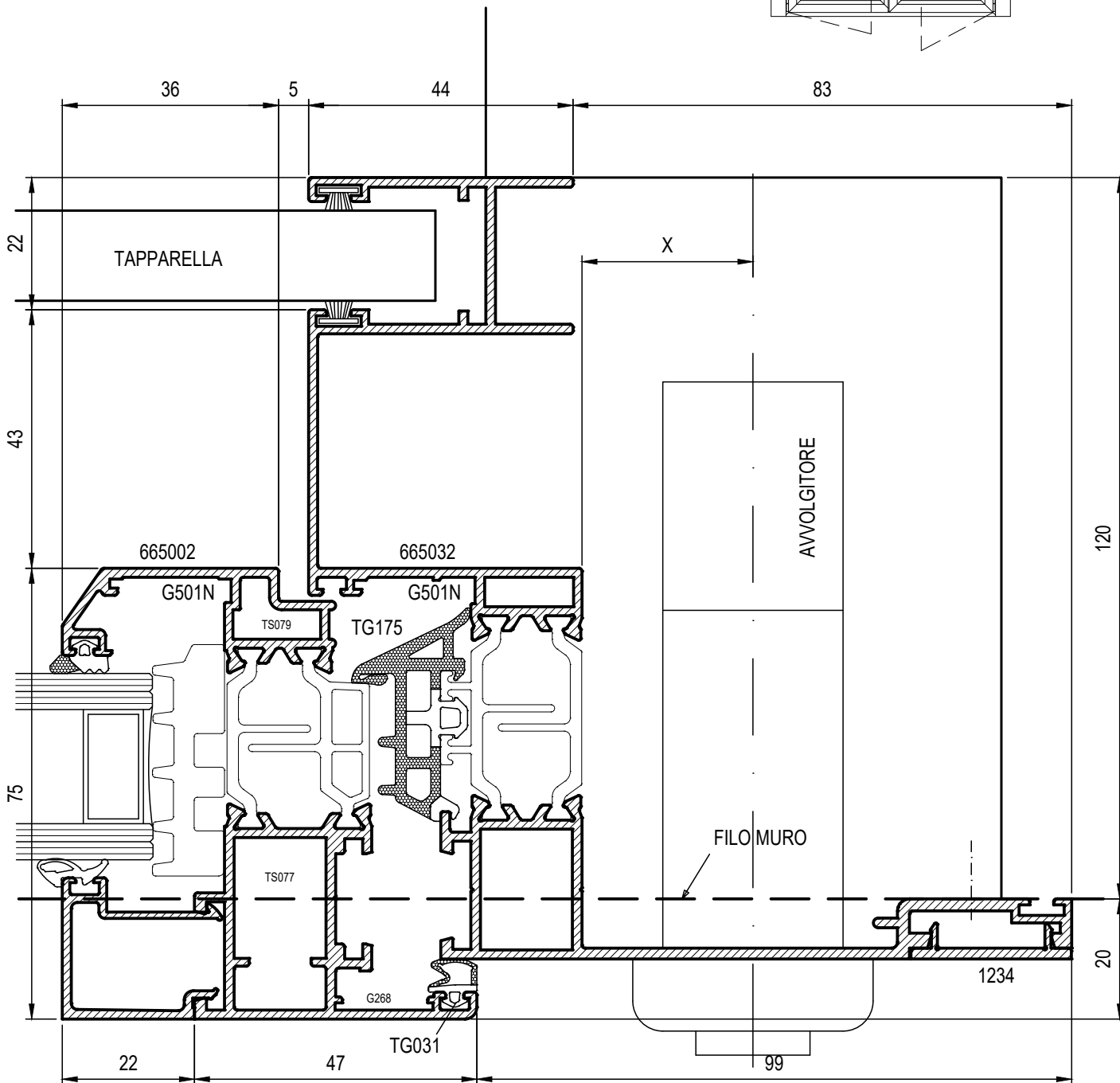
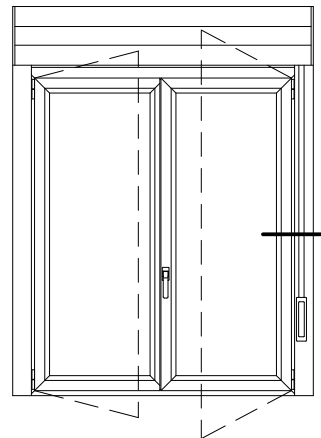

Nodi Scala 1:1



CIELINO MONOBLOCCO

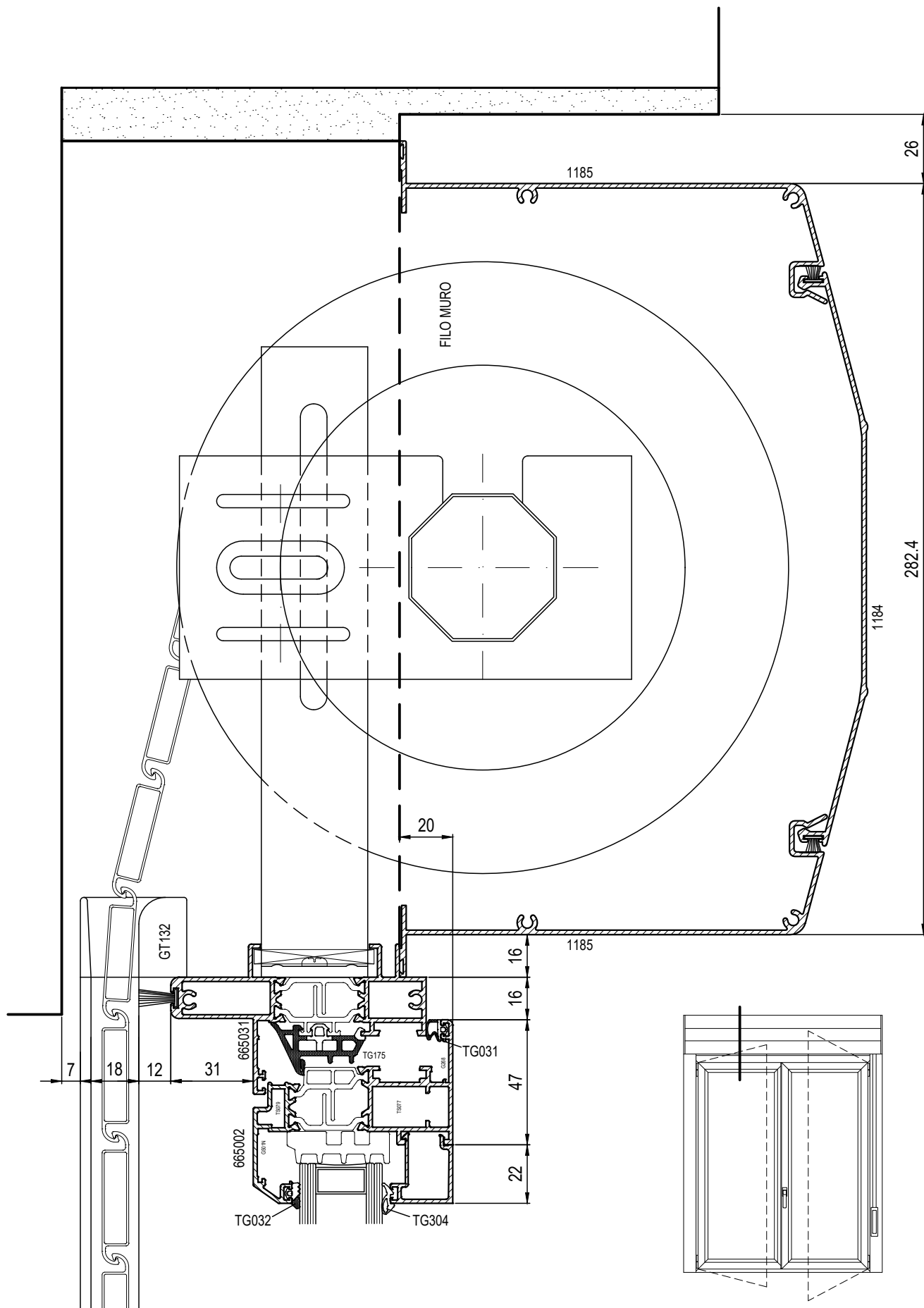

SCORREVOLE PARALLELO
BINARIO INFERIORE

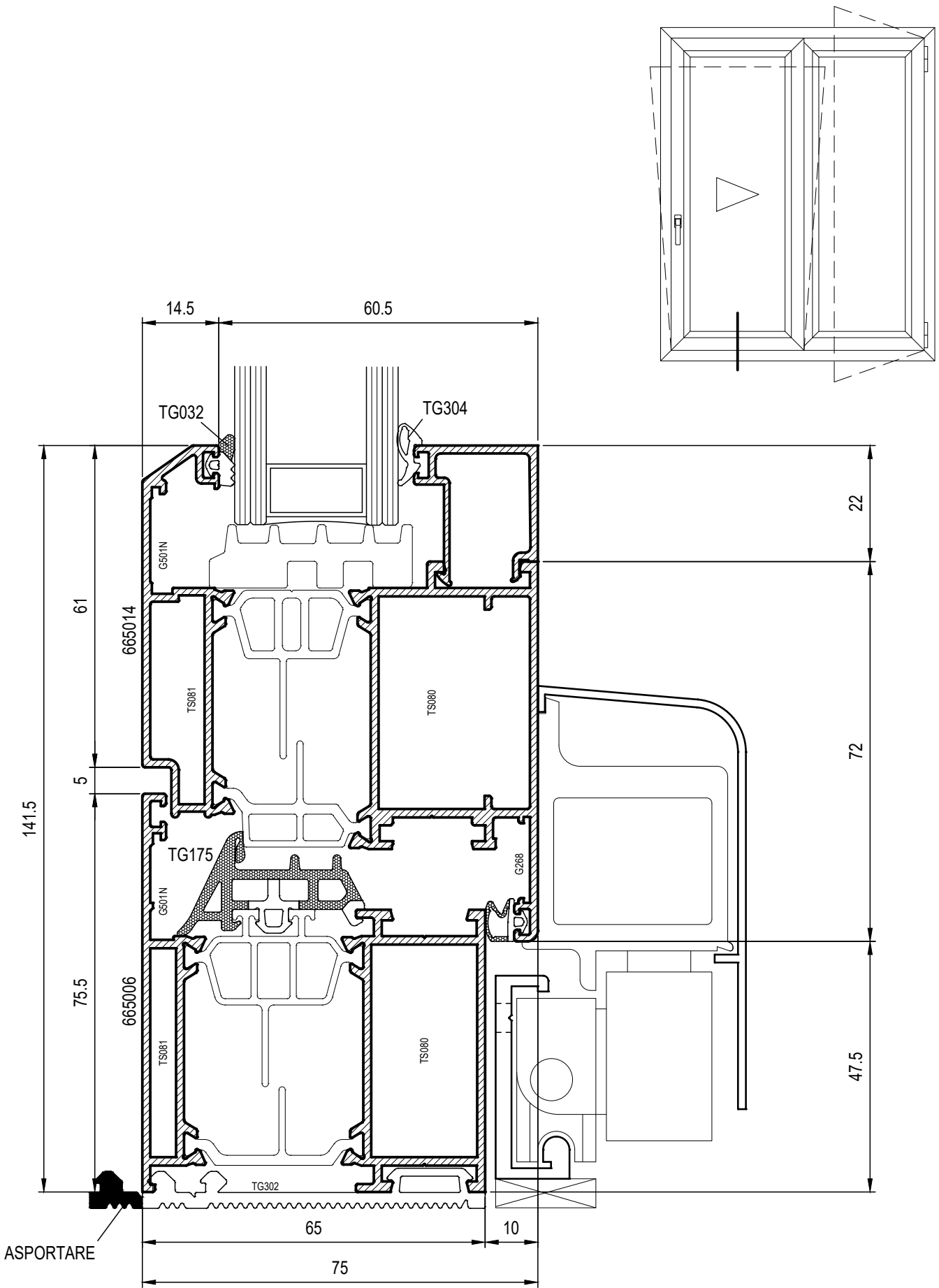

Nodi Scala 1:1



SCORREVOLE PARALLELO
BINARIO SUPERIORE

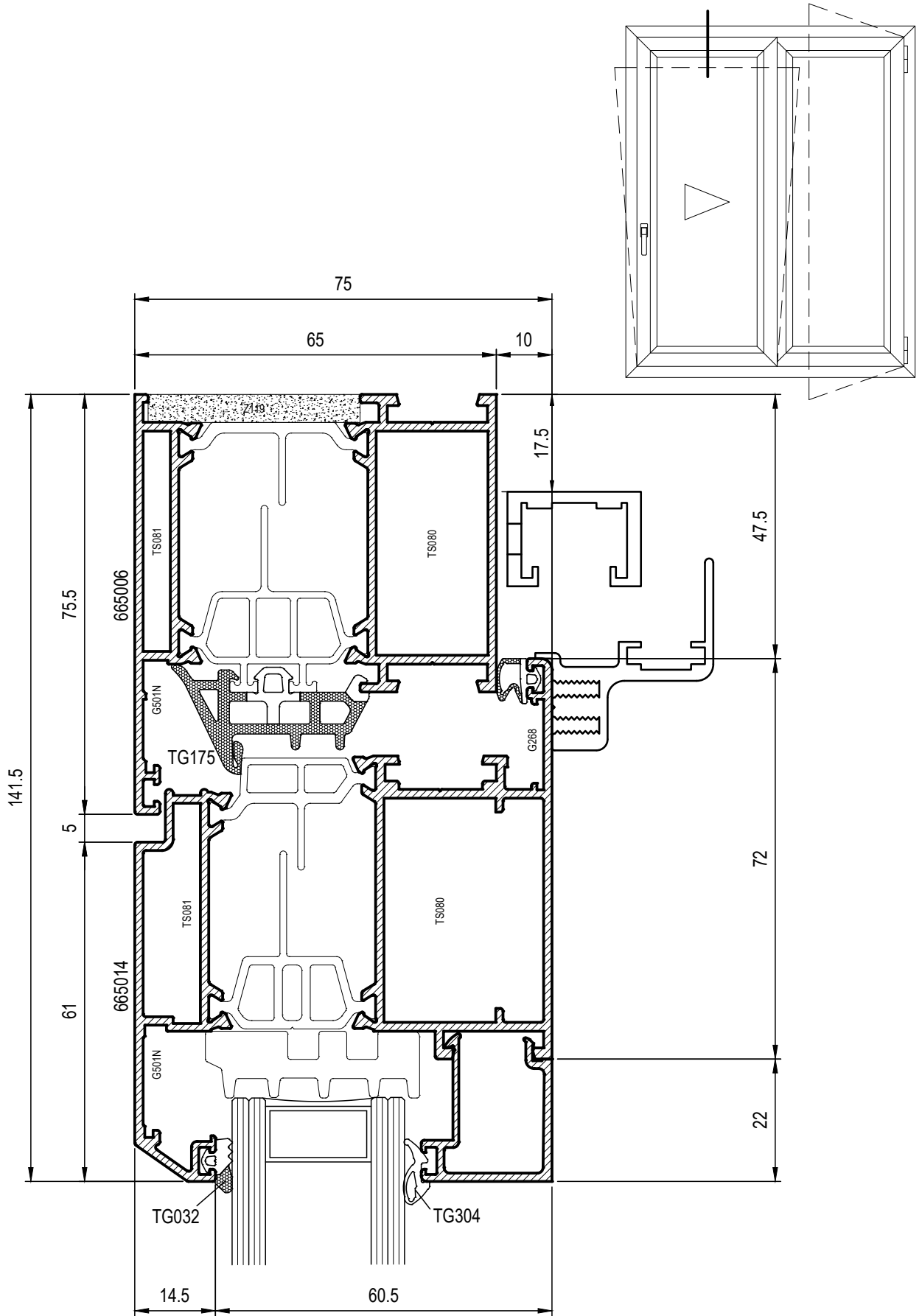

VETRINA CON INSERIMENTO SCORREVOLE PLATHINA 78S

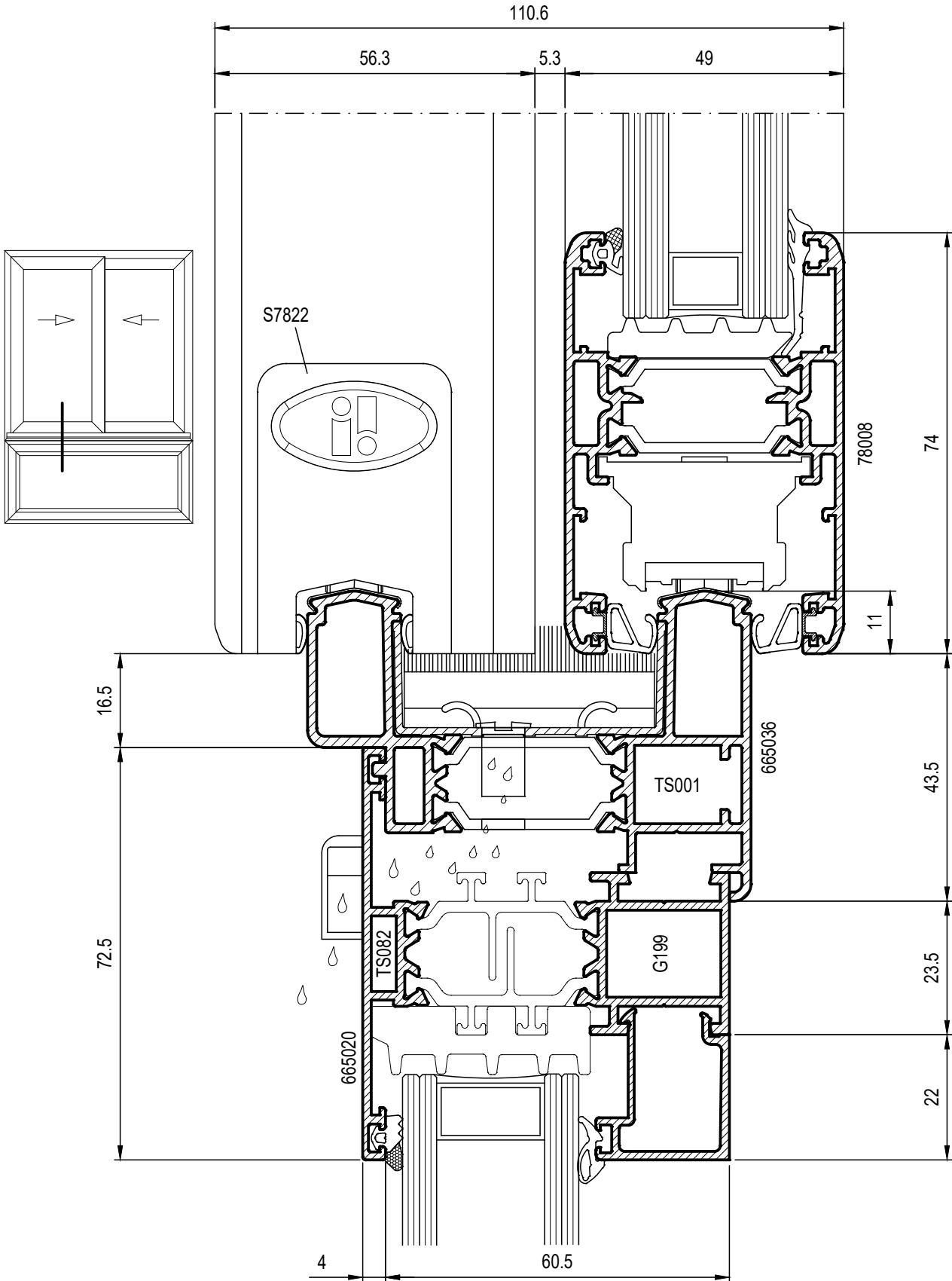

SCORREVOLE PLATHINA 78S CON SOPRALUCE

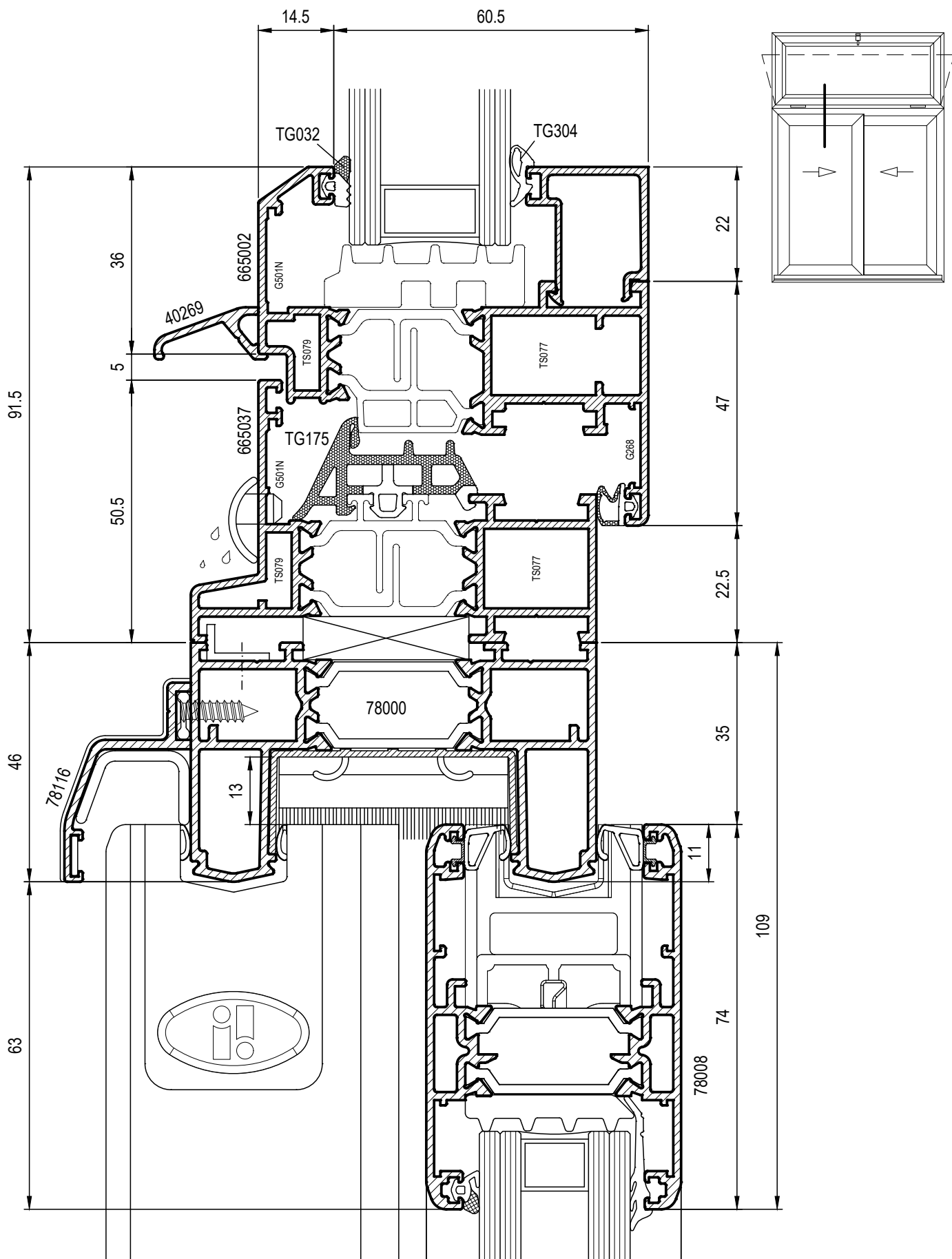

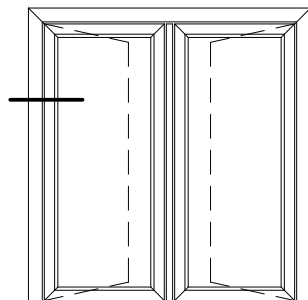
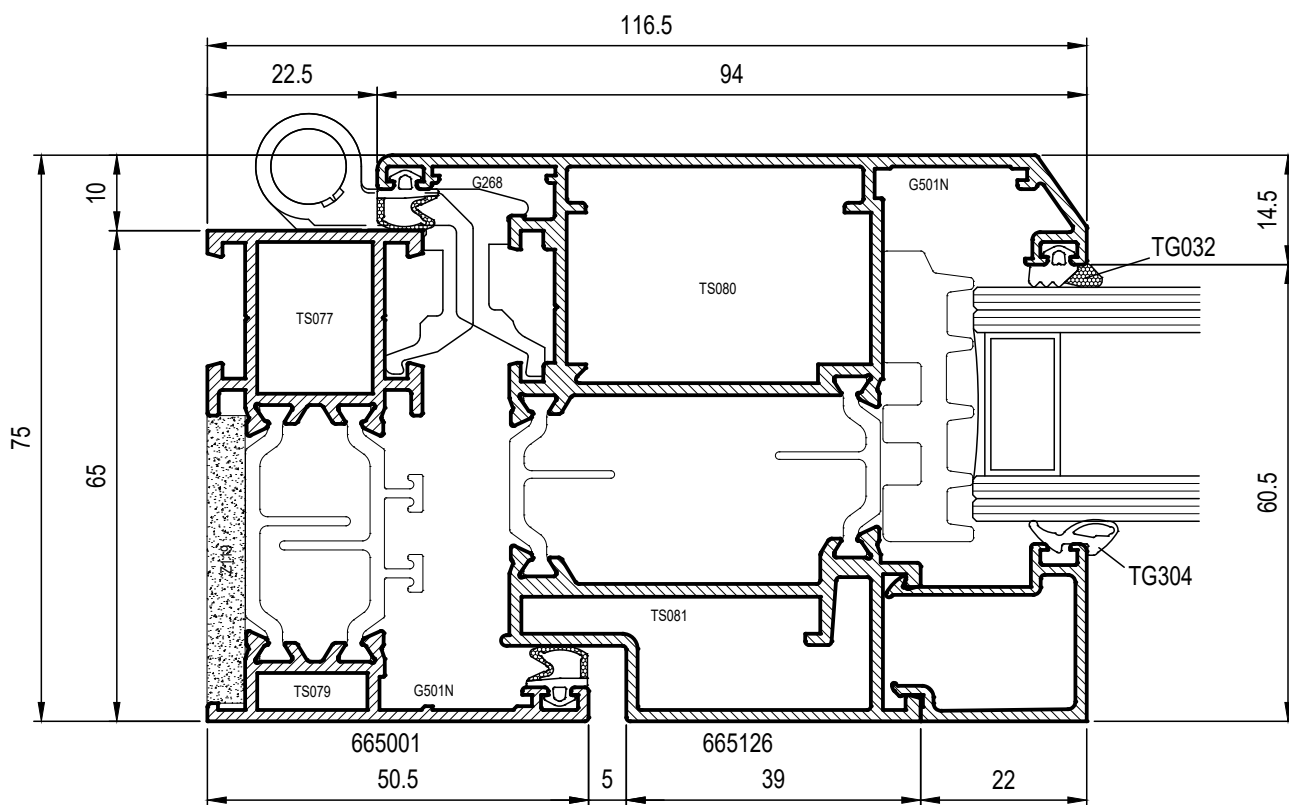

APERTURA ESTERNA DUE ANTE

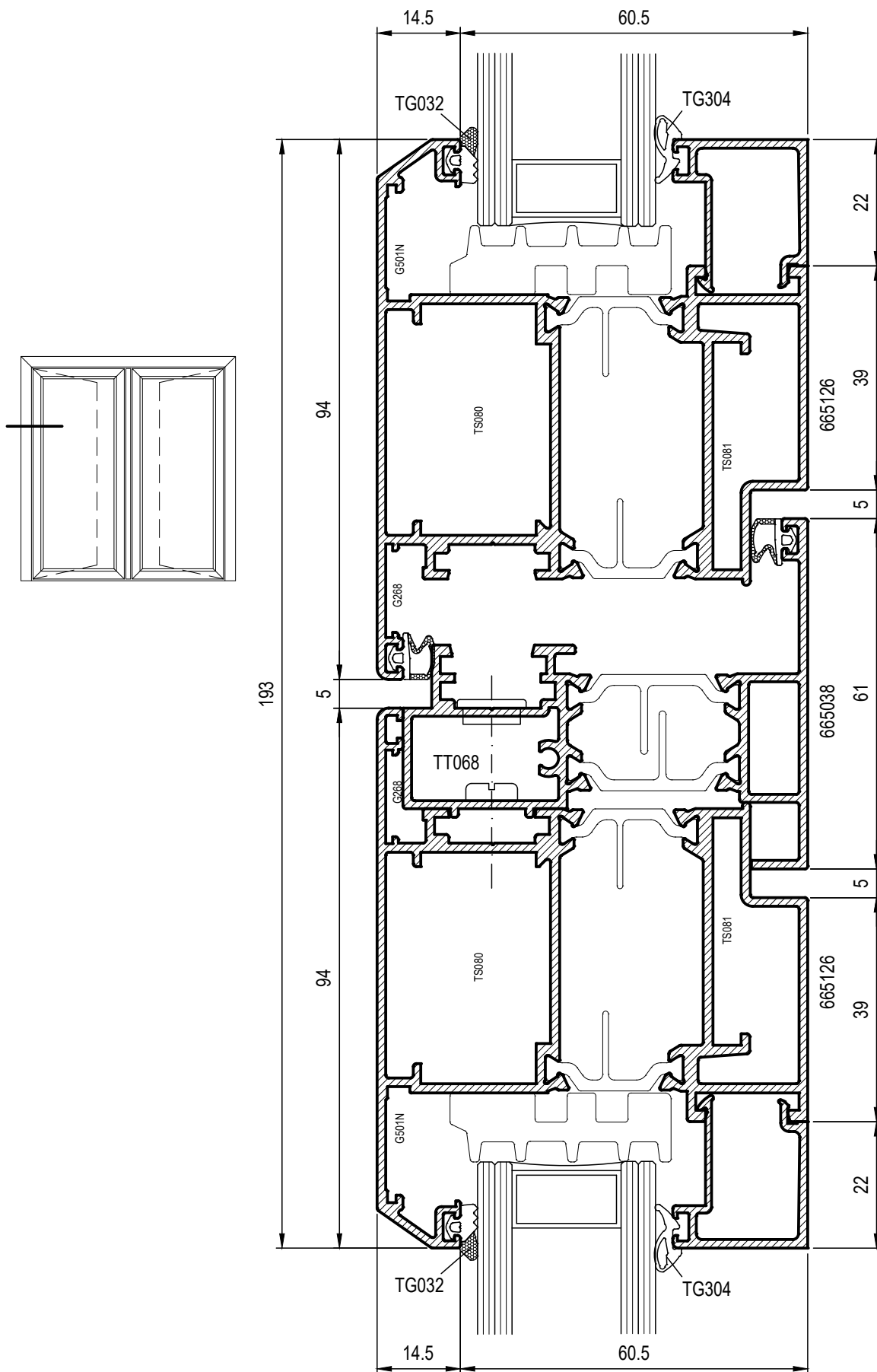

APERTURA ESTERNA DOPPIA BATTUTA INSERIMENTO IN VETRINA

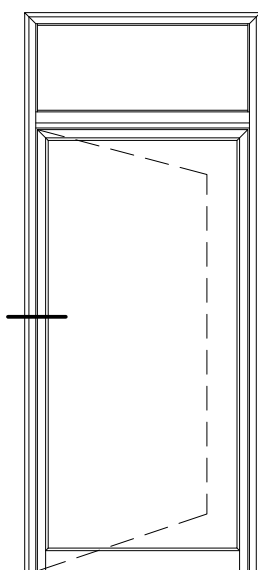
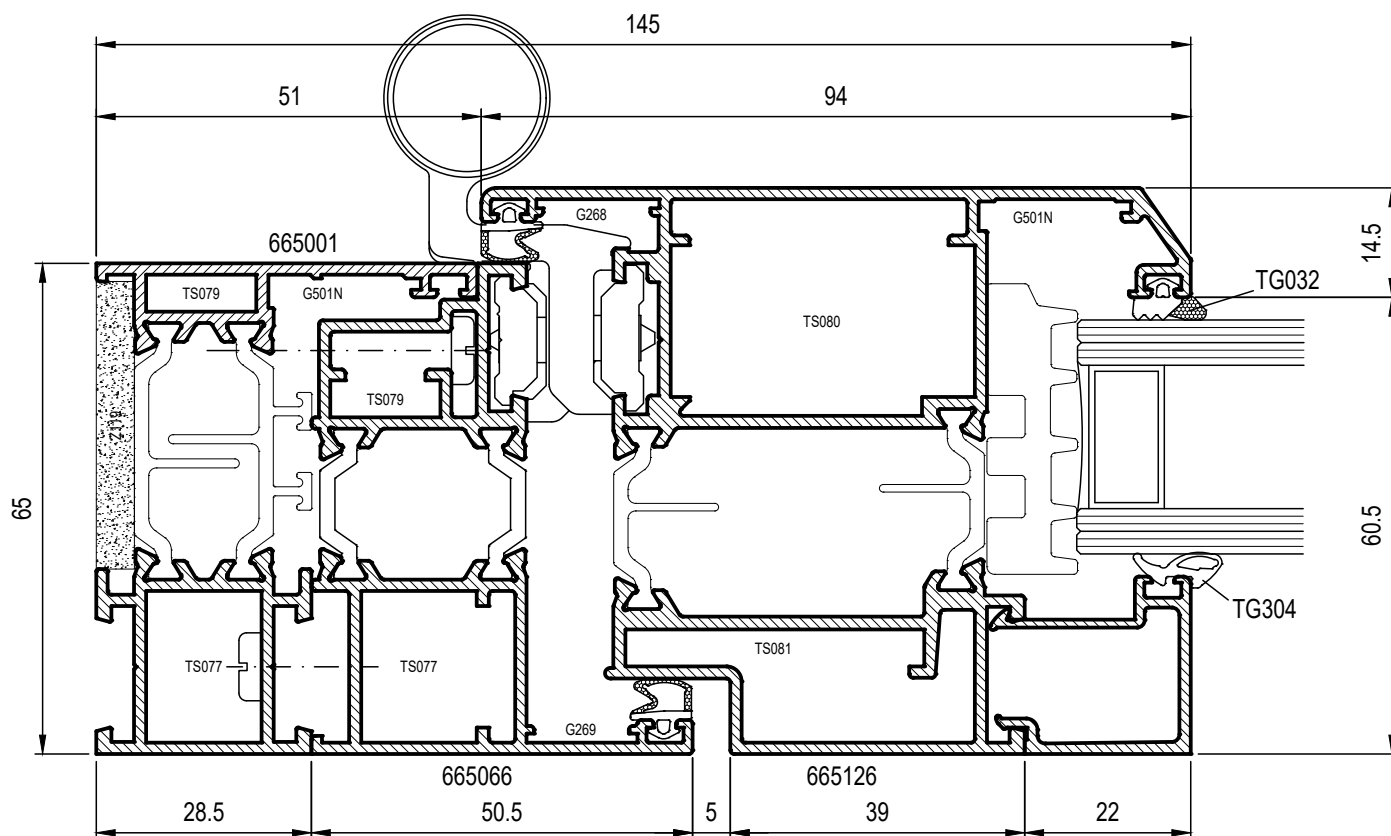

APERTURA INTERNA DOPPIA BATTUTA

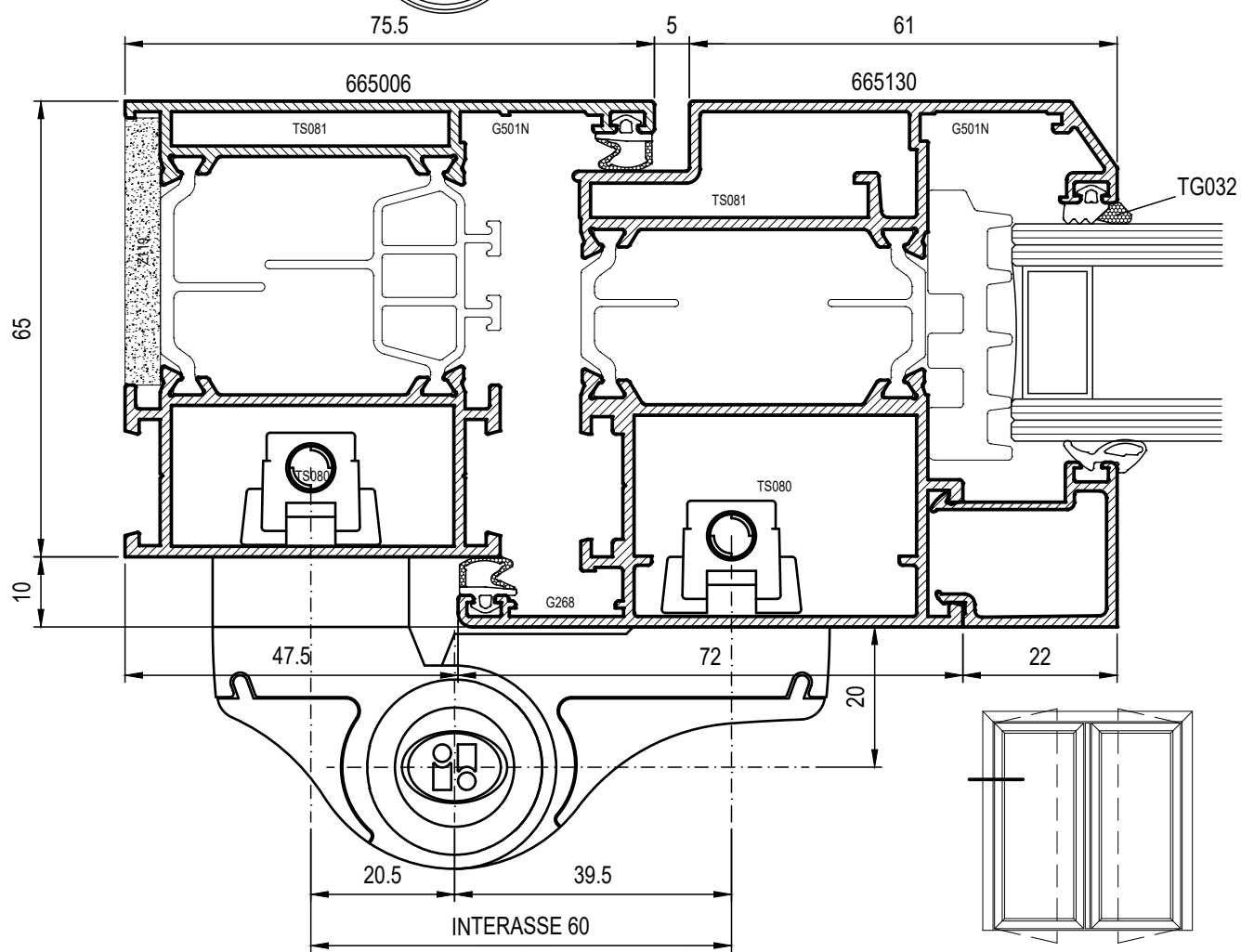
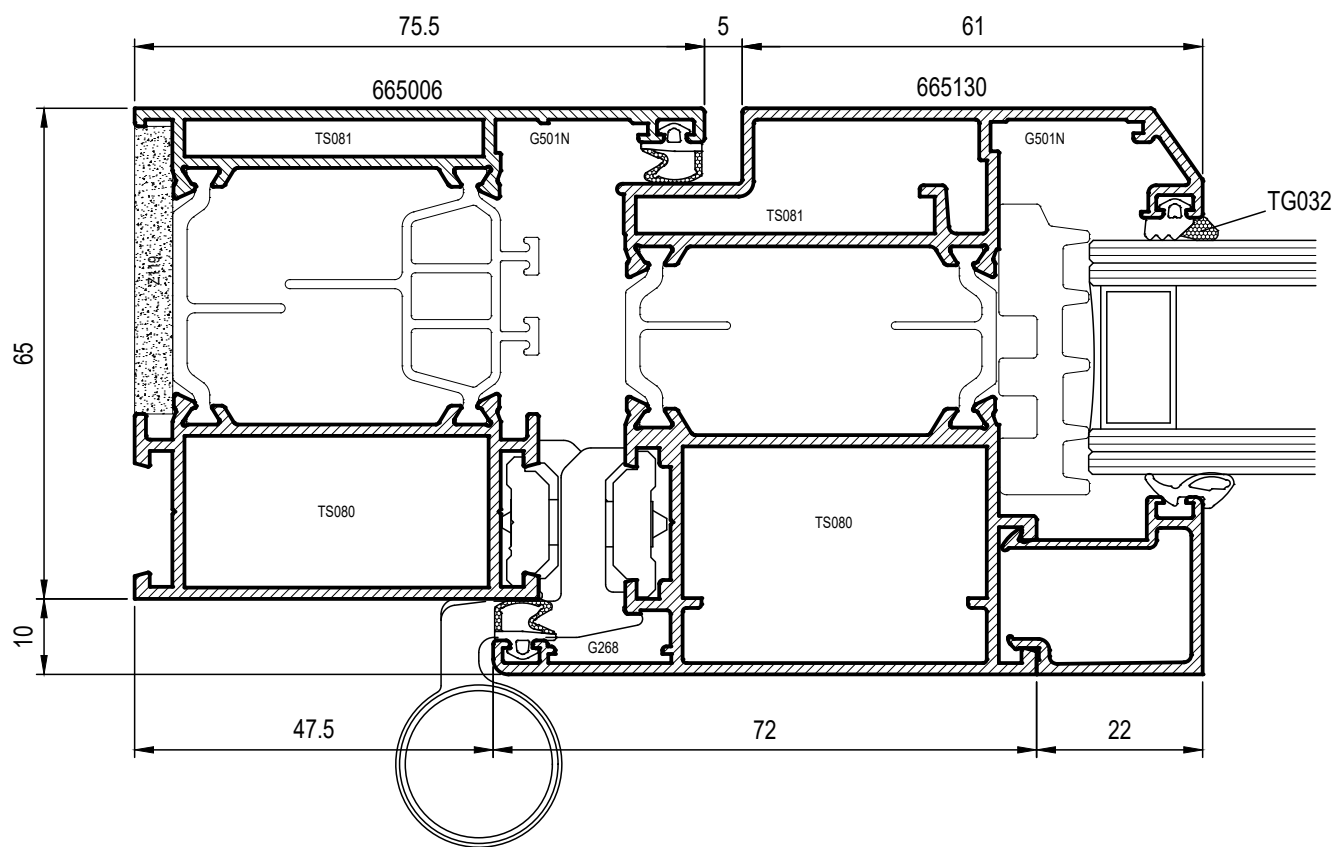

APERTURA INTERNA DUE ANTE DOPPIA BATTUTA

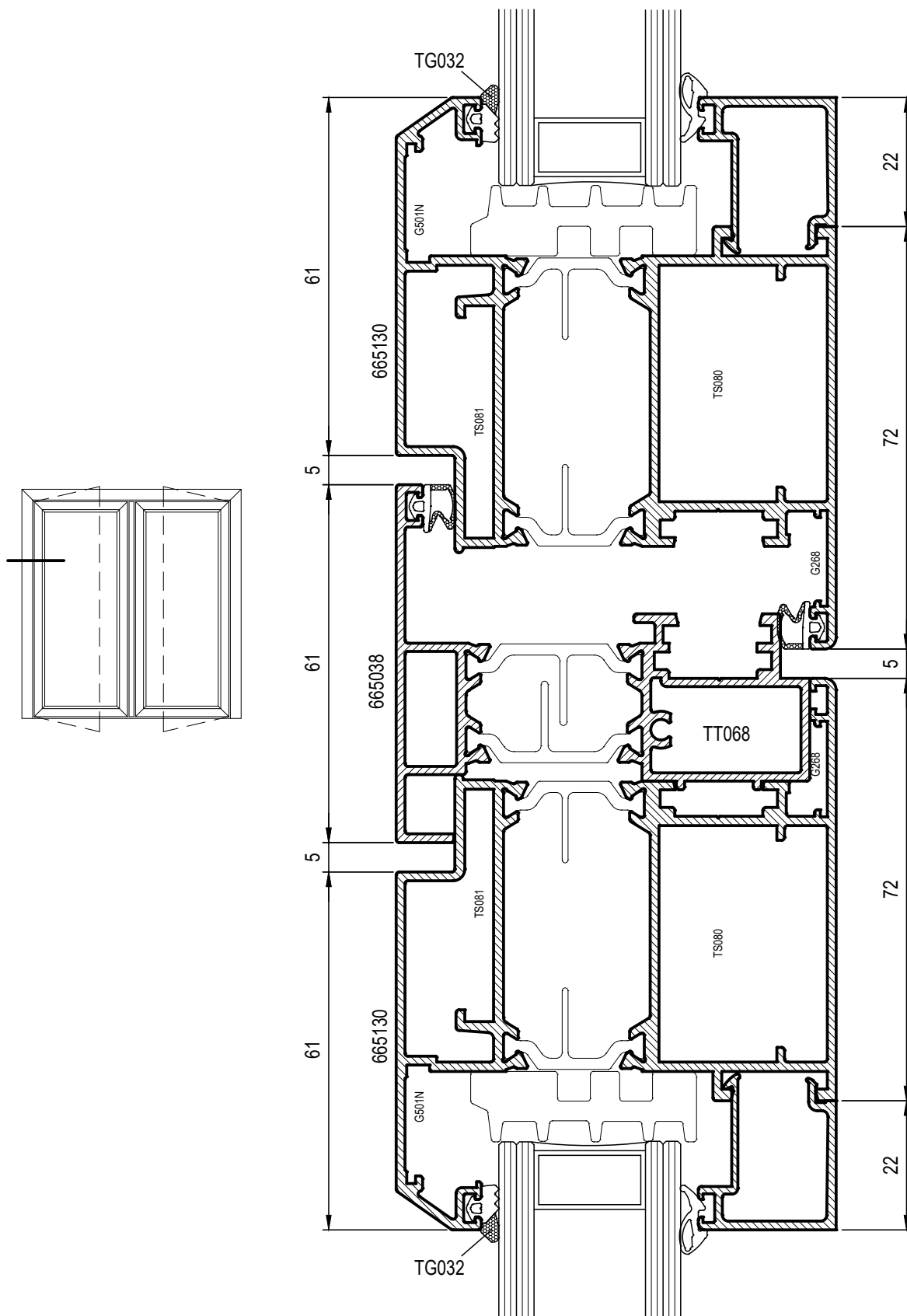

APERTURA INTERNA PROFILATI MAGGIORATI

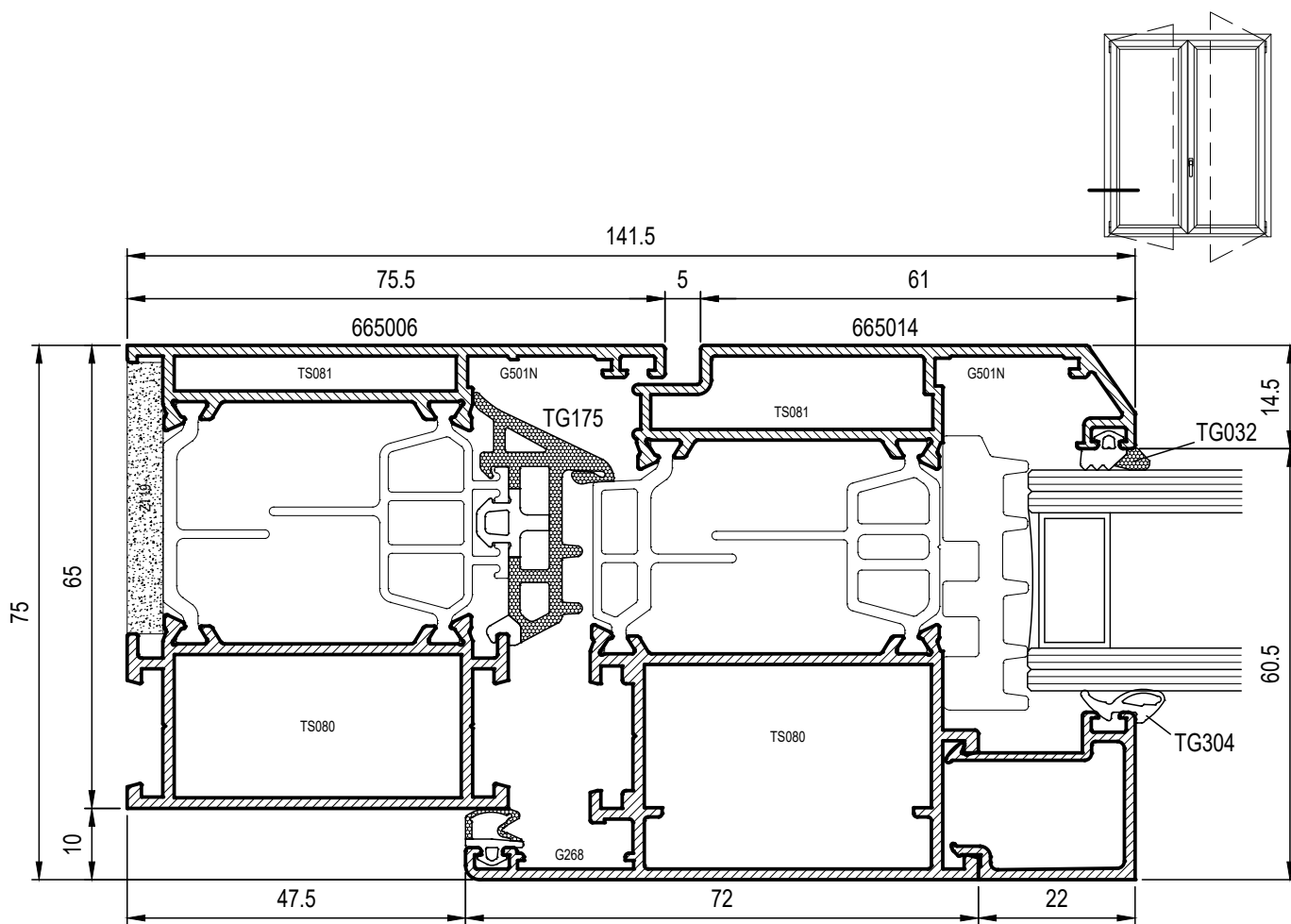

PROFILATO COMPENSATORE

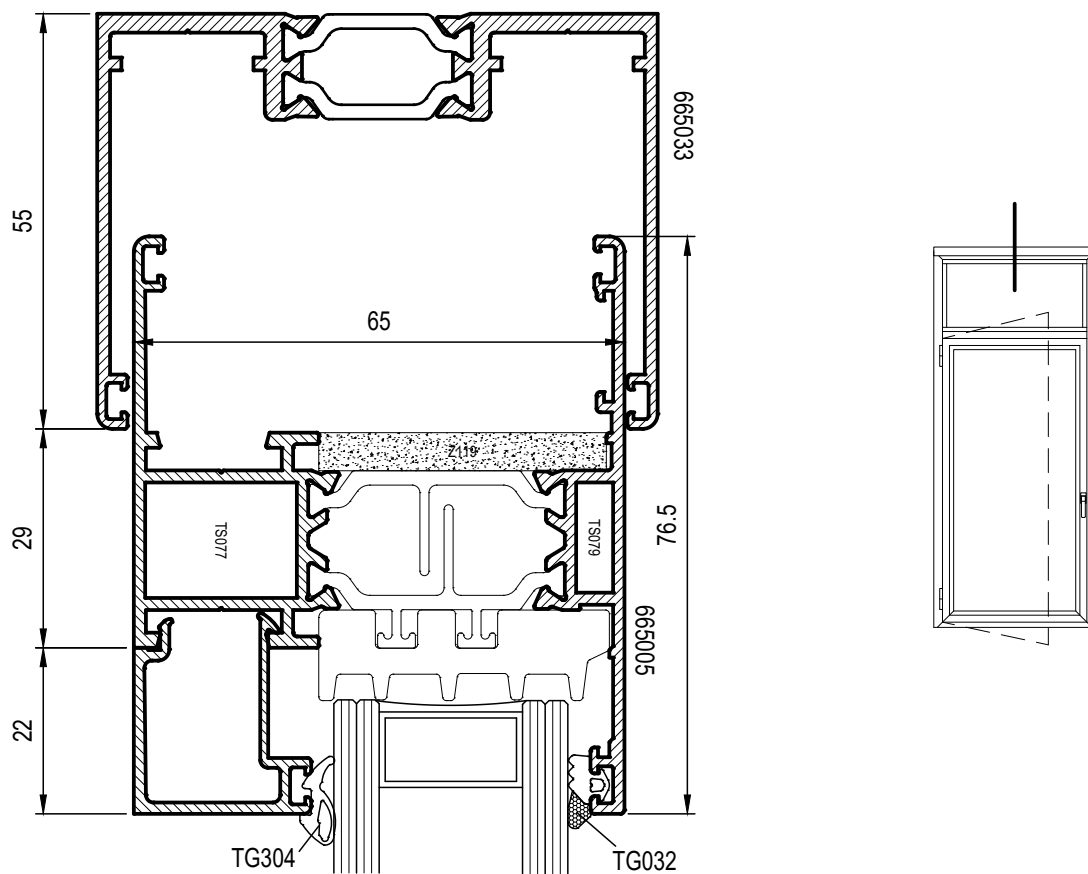

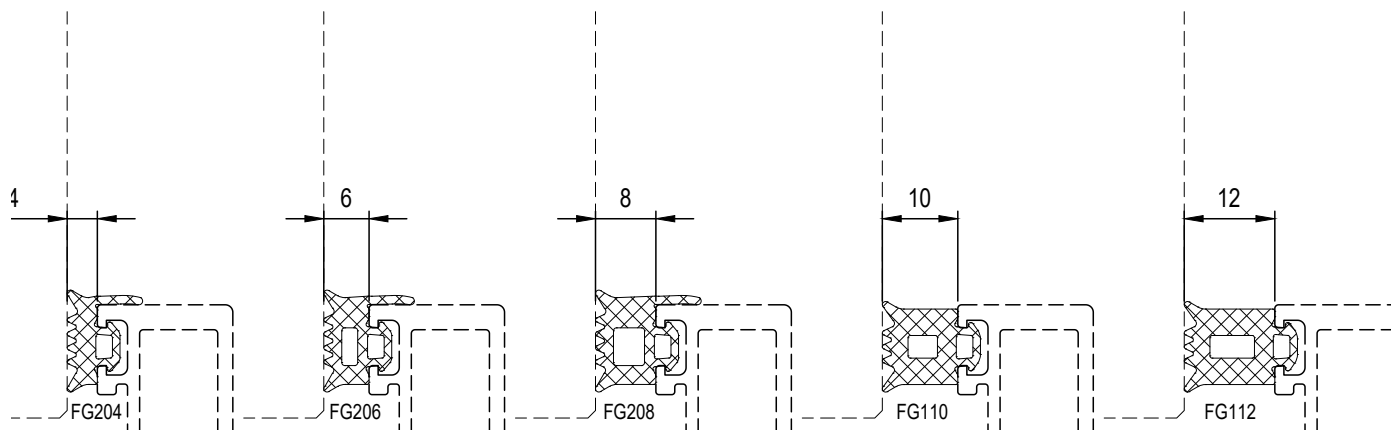
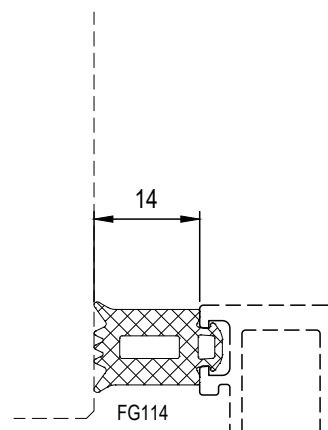
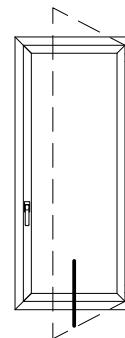
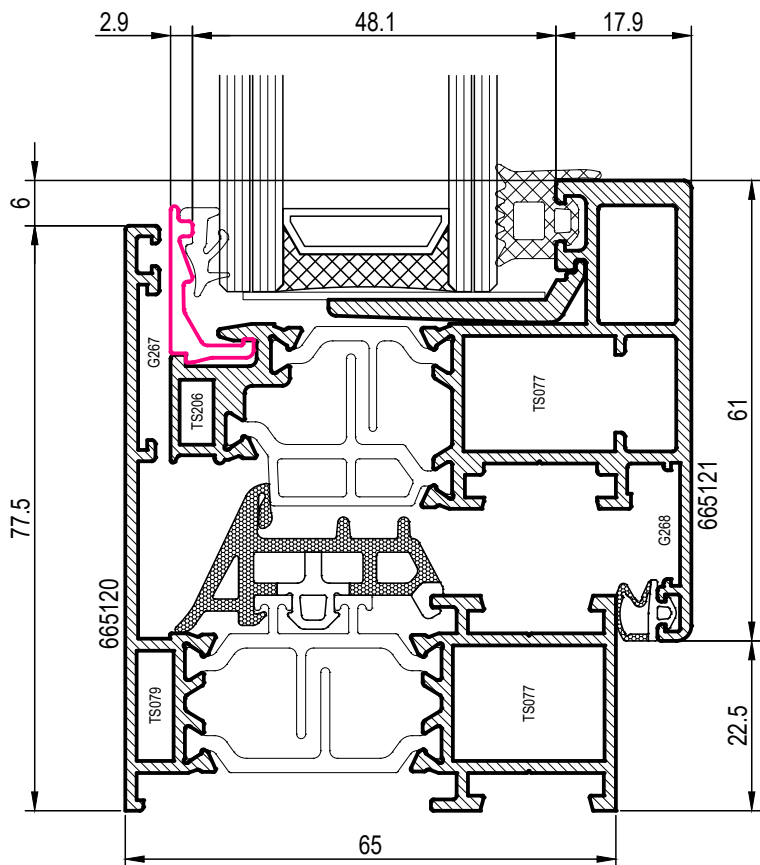

Nota Scala 1:1



APERTURA INTERNA PROFILATO CAPANNONE

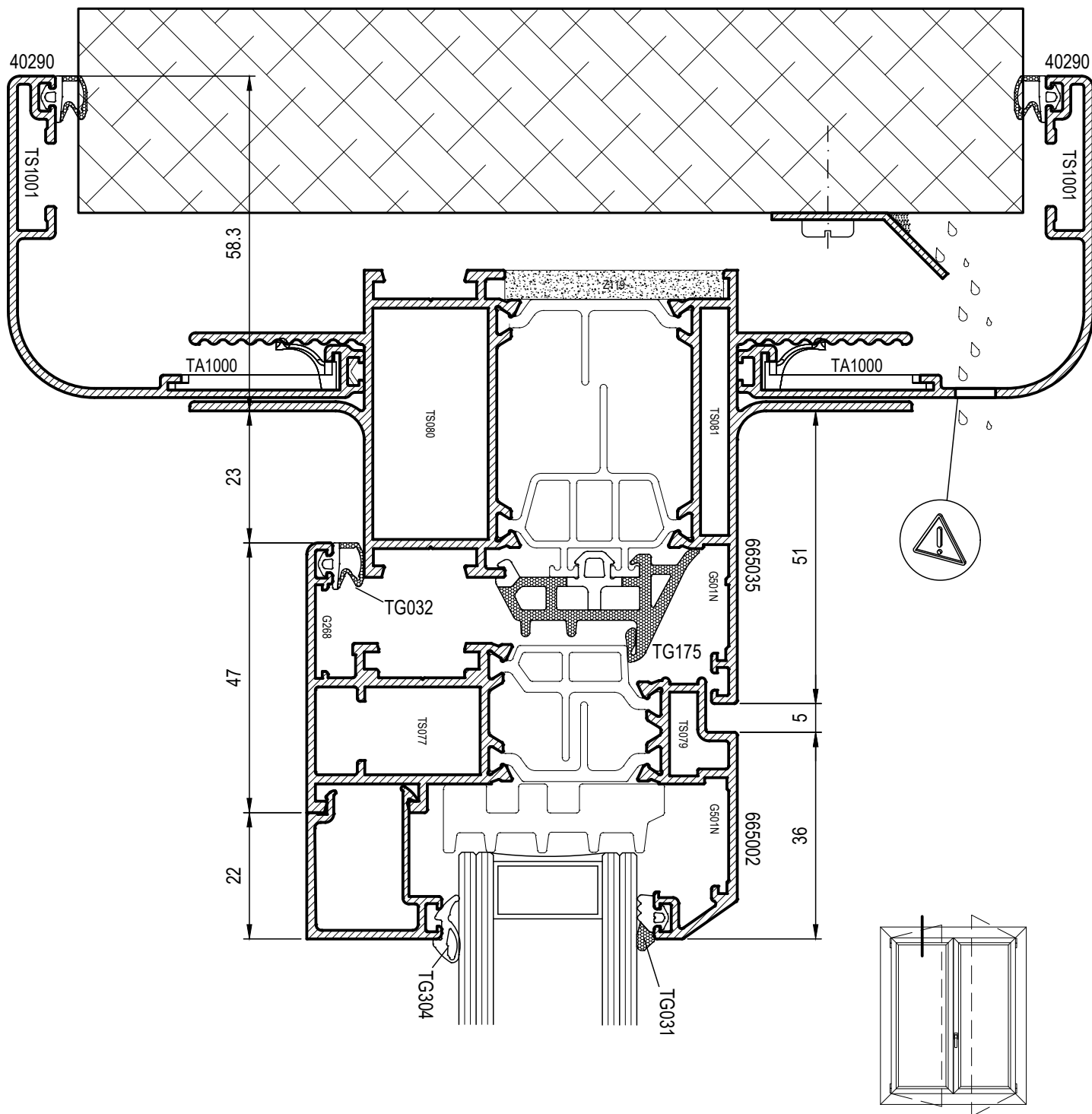



INDINVEST LT S.r.l. a socio unico
S.P. Ninfina II Km 1,200
04012 - Cisterna di Latina (LT)
Tel. +39.06.960.27.1

Per informazioni:
www.indinvest.it
ufficio.tecnico@indinvest.it