



INDINVEST LT

ALUMINIUM  EVOLUTION

Catalogo Generale



INDICE

Introduzione Tecnica	
Elenco Accessori	
Elenco Guarnizioni	
Elenco Attrezzature	
Profilati ed Inerzie	
Profilati Scala 1:1	
Soluzioni Disponibili	
Schede di Taglio	
Nodi Scala 1:1	

**FINO A NUOVA STAMPA CARTACEA GLI AGGIORNAMENTI
SONO DISPONIBILI SUL SITO WWW.INDINVESTLT.IT**



Introduzione Tecnica

CATALOGO TECNICO - INDICAZIONI GENERALI

MANUALE D'USO

Le informazioni contenute all'interno di questo Catalogo / Manuale, quando seguite scrupolosamente, permettono la realizzazione di infissi efficienti, sicuri e di lunga durata.

Alcune parti di questa documentazione, come ad esempio le distinte di taglio dei profilati, sono il risultato di calcoli teorici che possono risentire di fattori esterni, quali tipo e spessore della finitura superficiale, modello delle attrezzature utilizzate etc. E' quindi sempre consigliato, prima di procedere alla realizzazione delle commesse, eseguire una campionatura preventiva di prova in dimensioni reali, allo scopo di verificare lavorazioni, assemblaggi e prestazioni.

RISERVE GIURIDICHE

I disegni e le informative contenute in questo catalogo sono fornite a solo titolo indicativo e non possono costituire titolo di rivalsa nei confronti della INDINVEST LT s.r.l.

INDINVEST LT s.r.l. declina ogni responsabilità su eventuali errori di stampa o sull'uso improprio del presente catalogo e si riserva la facoltà di modificarne il contenuto senza alcun obbligo di preavviso.

Il presente catalogo è di proprietà della INDINVEST LT s.r.l. così come i suoi contenuti ed immagini che non potranno essere copiati e riprodotti, anche solo parzialmente, o modificati in alcun modo senza la Sua autorizzazione scritta.

DIMENSIONE E PESO DEI PROFILATI

Le dimensioni dei profilati riportate sul presente catalogo sono teoriche, e quindi variabili in funzione delle tolleranze dimensionali di estrusione (in conformità alla norma UNI EN 12020-2), oltreché in conseguenza di trattamenti di finitura superficiale e di accoppiamento dei profili a taglio termico. Dette variazioni possono influenzare sensibilmente gli accoppiamenti dei profili e/o la facilità di inserimento di accessori o guarnizioni nelle sedi apposite.

Le barre dei profilati vengono fornite alla lunghezza di 6.80 m.

POSA IN OPERA

Nella posa in opera dei serramenti, è necessario valutare opportunamente la tolleranza da mantenere tra il contro-telaio ed il telaio in Alluminio.

Questa tolleranza è variabile secondo le condizioni presenti, ma deve essere comunque tale da garantire un fissaggio completo e sicuro.

L'attacco dei serramenti alle murature presenta varie possibilità di soluzione a seconda della situazione che si presenta, ma deve avvenire con viti, tasselli ed ancoraggi di buona qualità secondo le normali e consolidate regole della buona posa e del buonsenso.

Gli schemi, le lavorazioni, le sezioni e gli attacchi a muro riportati sul presente catalogo hanno valore esemplificativo e non limitativo; essi riguardano, infatti, solo una parte delle casistiche riscontrabili all'atto pratico, che sarebbero altrimenti troppo numerose da citare nella loro interezza.

A fronte di ciò, INDINVEST LT s.r.l. consiglia di fare riferimento alle norme cogenti per la corretta posa in opera dei serramenti.

GUARNIZIONI ED ACCESSORI

Dovranno essere utilizzate esclusivamente le guarnizioni e gli accessori originali studiati e prodotti a garanzia delle prestazioni del sistema. L'impiego di guarnizioni o accessori diversi da quelli indicati comporteranno l'inutilizzabilità dei certificati di prova.

SIGILLANTI

Dovranno essere utilizzati esclusivamente sigillanti con caratteristiche conformi a quanto prescritto dalle norme di riferimento Italiane ed Europee.

LAVORAZIONI

Le lavorazioni per l'assemblaggio dei profili dovranno essere praticate seguendo gli schemi, le distinte e le istruzioni impartite dal produttore del sistema. La realizzazione di infissi costruiti in difformità dalle indicazioni di montaggio fornite dal produttore di sistema comporteranno l'inutilizzabilità dei certificati di prova.

Allo scopo di limitare il processo di corrosione filiforme dell'alluminio si dovrà avere cura di utilizzare soltanto viterie in acciaio inox ed accessori supplementari in acciaio inox o alluminio in lega EN AW6060, oltre che sigillare le parti tagliate ed evitare ristagni di condensa interni.

VERNICIATURA

I profilati dovranno subire trattamenti superficiali conformi agli standard QUALICOAT e QUALANOD ed in caso di verniciatura dei profilati a taglio termico si dovranno supportare gli stessi con mezzi opportuni affinché non subiscano deformazioni durante il trattamento di cottura del rivestimento a 180° mantenendo l'originale rettilineità.

CARATTERISTICHE DELLE VETRAZIONI

La scelta della vetratura da installare sui serramenti realizzati con il sistema oggetto del catalogo dovrà essere effettuata secondo criteri prestazionali per rispondere ai requisiti di sicurezza, di risparmio energetico, di controllo della radiazione solare e di isolamento acustico fissati dalle leggi vigenti.

ISOLAMENTO TERMICO

La scelta delle prestazioni di isolamento termico di un serramento dovrà essere effettuata in conformità alla vigente normativa italiana in materia di risparmio energetico.

La trasmittanza termica di un serramento può essere calcolata in riferimento a quanto contenuto nella norma UNI EN 13830; UNI EN ISO 1263 e per il calcolo secondo le modalità di calcolo riportate nella UNI EN 10077-1-2.

ISOLAMENTO ACUSTICO

La scelta della classe di isolamento acustico di un serramento sarà legata alla destinazione d'uso del locale nel quale l'infisso dovrà essere inserito, oltre che al livello ed alla natura del rumore esterno. Le prestazioni acustiche del serramento in opera sono influenzate da fattori noti (classe di permeabilità all'aria dell'infisso, potere fono isolante del vetro) e da fattori non definibili a priori (altezza dal suolo, presenza di parapetti, orientamento delle sorgenti, sporgenze, spettro sonoro, modalità d'installazione. I valori da rispettare sono quelli indicati dalla vigente normativa Italiana misurabili secondo e le relative norme Europee.

SICUREZZA SUL LAVORO

Le procedure di realizzazione e montaggio in sicurezza dei serramenti, nel rispetto della normativa italiana in tema di salute e sicurezza, sono a cura dei serramentisti. I serramenti dovranno essere concepiti secondo le prescrizioni della normativa vigente Italiana ed Europea in materia di sicurezza delle applicazioni vetrarie e della UNI in materia di marchio CE.

LIMITI D'IMPIEGO

Le dimensioni massime dei serramenti, dei pesi delle ante e degli accessori sono da verificarsi e da determinarsi a cura del costruttore in funzione della geometria dei profilati, della massa, del peso delle vetrazioni/ pannellature, della qualità e della portata degli accessori utilizzati, delle condizioni d'installazione, delle condizioni di applicazione (altezza dal suolo, esposizione, ecc.), e delle condizioni climatiche (velocità di riferimento dei venti, esposizione alla pioggia, ecc.). al costruttore di serramenti si consiglia di fare riferimento alle vigenti normative Europee ed Italiane.

CONSIGLI COSTRUTTIVI PER LIMITARE L'INSORGENZA DI CORROSIONE:

La corrosione filiforme è uno dei problemi più insidiosi che possano manifestarsi nei profilati in Alluminio.

Al fine di contrastarne l'insorgenza, occorre prestare particolare attenzione ad alcuni aspetti in fase di costruzione e posa degli infissi.

In particolare:

Nei limiti del possibile utilizzare per le giunzioni squadrette e cavallotti in Alluminio estruso, lega 6060 o pressofuso, lega UNI 5076.

Le viti di fissaggio devono essere in acciaio inox.

Le parti soggette a taglio o fresature devono essere sigillate accuratamente, con specifici prodotti adatti allo scopo (colle bicomponente ecc.).

Evitare ristagni di acqua (spesso dovuti a fenomeni naturali di condensa), all'interno dei profilati.

SITO INTERNET ED AGGIORNAMENTI

Per aggiornamenti del catalogo e per ogni ulteriore informazione è possibile visitare il nostro sito internet all'indirizzo: WWW.INDINVESTLT.IT

DIAGRAMMI DEI LIMITI DI IMPIEGO

PROFILATI ART. 175002 - 175003 - 175002

- I valori di altezza e larghezza riportati nel diagramma si riferiscono alle dimensioni delle ante.
- Verificare che la freccia del profilato sia compatibile con il vetro impiegato.
- I diagrammi qui riportati non prendono in considerazione la resistenza degli accessori.
- Le curve indicano le dimensioni massime relative alle pressioni indicate

Curve con freccia max 1/300 di H

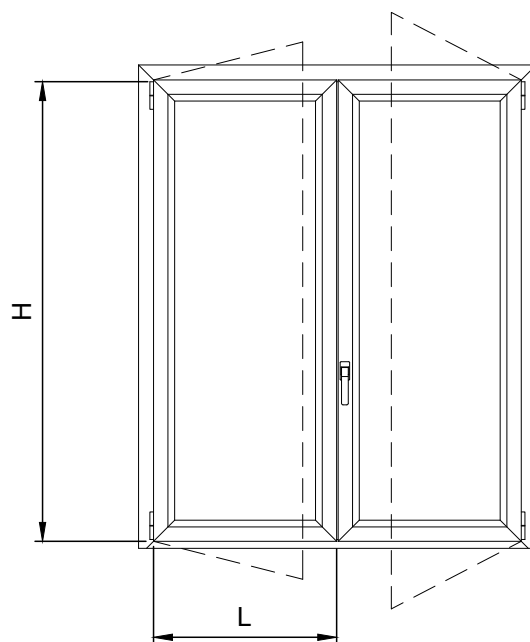
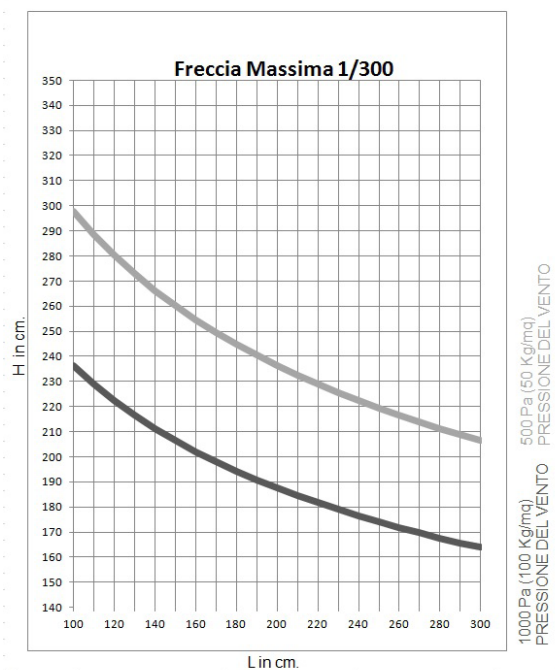

Curve con freccia max 1/200 di H

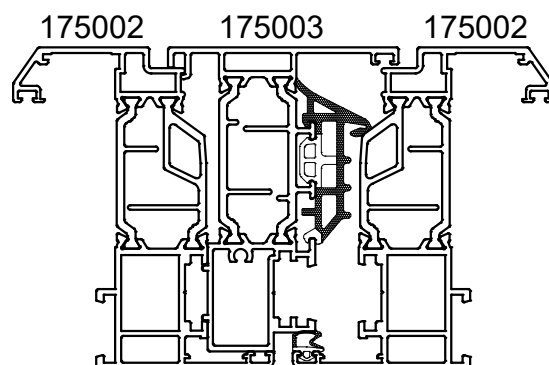
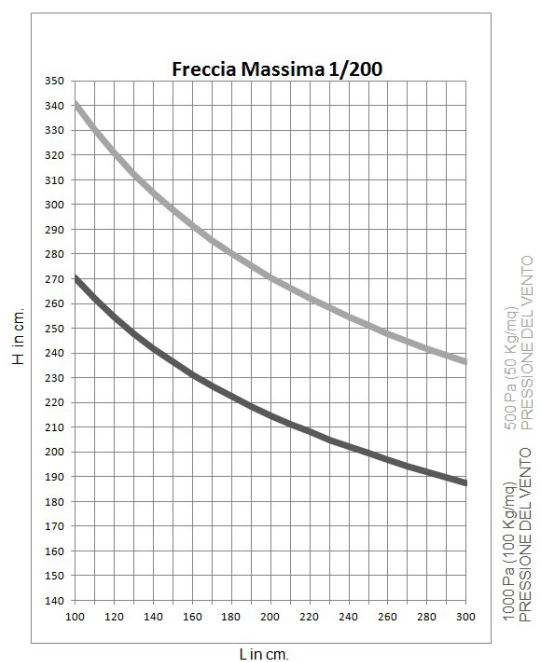

DIAGRAMMI DEI LIMITI DI IMPIEGO

PROFILATI ART. 175014 - 175003 - 175014



- I valori di altezza e larghezza riportati nel diagramma si riferiscono alle dimensioni delle ante.
- Verificare che la freccia del profilato sia compatibile con il vetro impiegato.
- I diagrammi qui riportati non prendono in considerazione la resistenza degli accessori.
- Le curve indicano le dimensioni massime relative alle pressioni indicate

Curve con freccia max 1/300 di H

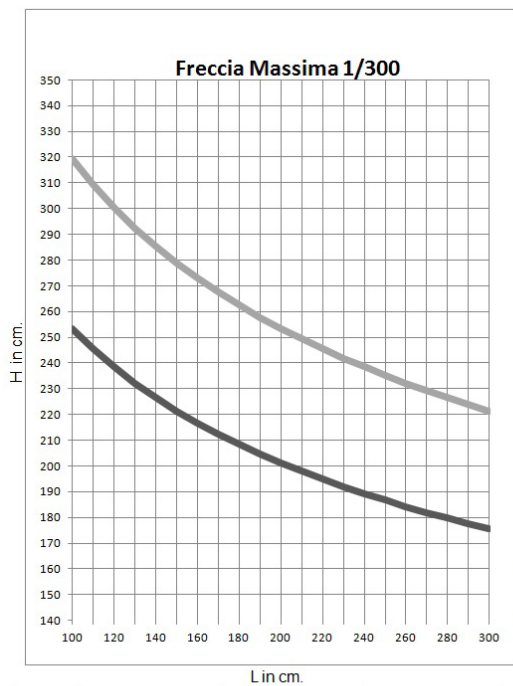

1000 Pa (100 Kg/mq)
PRESSIONE DEL VENTO

500 Pa (50 Kg/mq)
PRESSIONE DEL VENTO

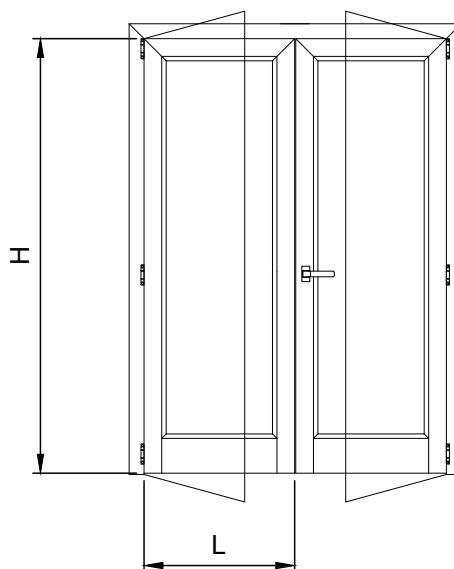

Curve con freccia max 1/200 di H

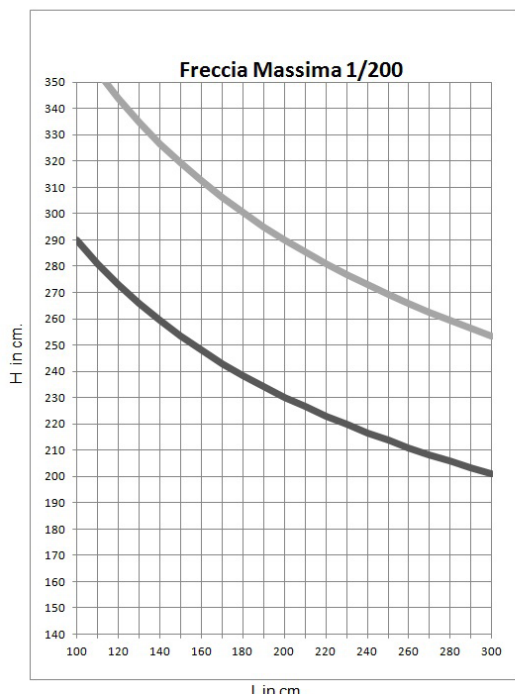

1000 Pa (100 Kg/mq)
PRESSIONE DEL VENTO

500 Pa (50 Kg/mq)
PRESSIONE DEL VENTO

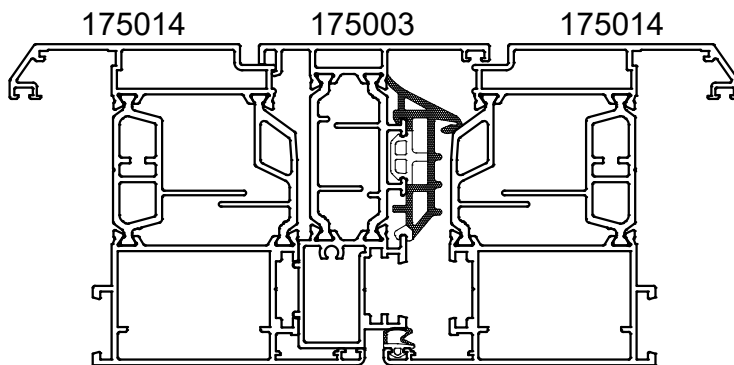

DIMENSIONE MINIMA ANTA

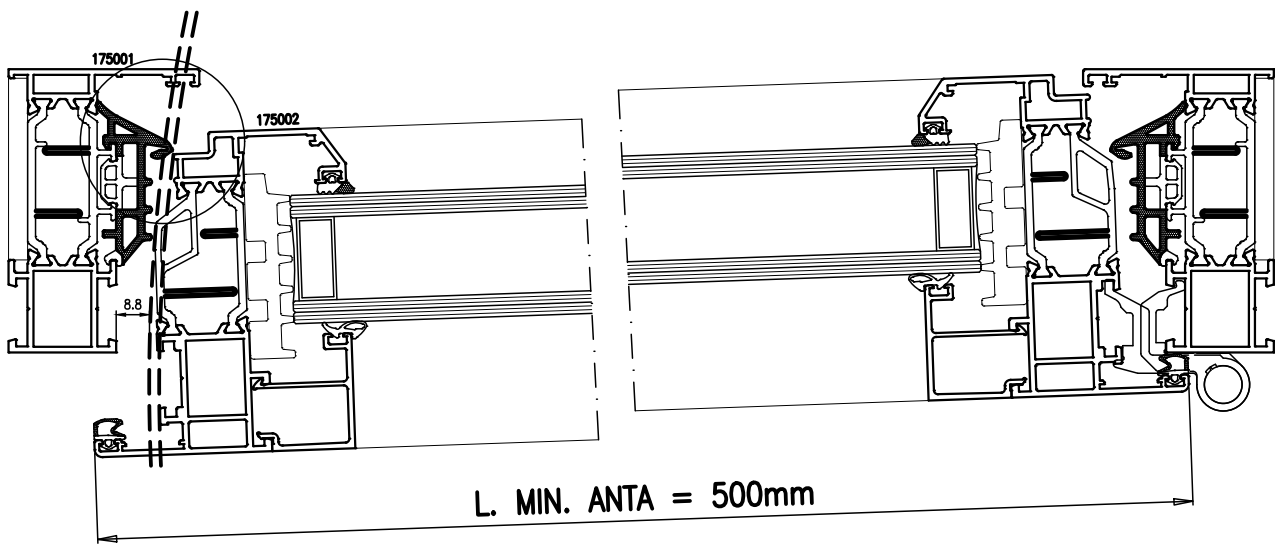

CON LARGHEZZA ANTA = 500 mm

TRA LA GUARNIZIONE TG185 E IL PROFILATO IN ROTAZIONE
RIMANE UNO SPAZIO TEORICO DI POCO MENO DI 1 mm

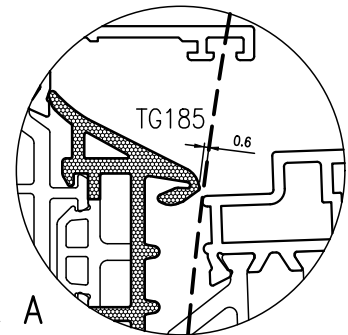

PART. A

DESCRIZIONE PER CAPITOLATO

Serramenti costruiti con profilati estrusi in lega di alluminio 6060 (EN 573-3), con stato di fornitura T6 (EN 515) e tolleranze su dimensioni e spessori secondo UNI EN 12020.2 e/o UNI EN 755-9.

Il telaio fisso avrà una profondità di 75 mm. e quello mobile di 85 mm. così da assicurare una maggiore resistenza strutturale alle elevate pressioni del vento. La tubolarità in cui sono contenute le squadrette di giunzione degli angoli avrà una larghezza di 18,5 mm., comprensivi di spessore delle pareti del profilato, sia per i telai fissi che per quelli mobili. Per serramenti di rilevanti dimensioni dovranno essere usati per i telai mobili profilati aventi larghezza maggiorata a 43,5 mm. L'aletta di sovrapposizione al muro nella parte interna non dovrà essere inferiore a 26 mm. e dovrà avere una sede per l'alloggiamento della guarnizione di battuta. I profilati avranno caratteristiche di taglio termico, cioè vi sarà separazione tra parte esterna ed interna dei profilati stessi, al fine di contenere il passaggio di calore tra le due parti. Il taglio termico dovrà essere ottenuto mediante l'inserimento di listelli complanari in poliammide rinforzata con fibre di vetro, della profondità totale di 44 mm per il telaio e 40 mm per l'anta. e spessore di 2 mm. Il bloccaggio delle barrette sarà meccanico, con rullatura dei dentini di ancoraggio dall'esterno previa loro zigrinatura per evitare scorrimenti.

Il valore della trasmittanza termica U_f nella configurazione standard non dovrà essere superiore a 1,2 W/ m²K sia per la sezione laterale che per la sezione centrale.

DOGMA PRO

Il sistema di tenuta all'aria sarà a giunto aperto, cioè con guarnizione centrale in E.P.D.M. in doppia densità montata sul telaio fisso ed appoggiante direttamente sull'apposita pinna in poliammide presente sul telaio mobile. Inoltre per ridurre la trasmissione termica e per garantire sempre la corretta ventilazione perimetrale del vetrocamera il perimetro dei tamponamenti (vetro o pannello) sarà contornato da apposita guarnizione isolante in PEX, mentre quello del telaio da guarnizione auto espandente in poliuretano.

Nella traversa inferiore del telaio fisso dovranno essere realizzate delle asole per lo scarico dell'acqua, dotate di apposite cappette in nylon di protezione. Gli angoli dei profilati e della guarnizione centrale dovranno essere sigillati per evitare possibili infiltrazioni di aria e acqua.

In caso di utilizzo di vetri isolanti, nelle traverse inferiori e nei montanti laterali delle ante mobili dovranno essere realizzate altresì asole per lo scarico dell'eventuale acqua di condensa e per la corretta aerazione del vetro.

Il serramento finito presenterà una superficie esterna piana (complanare), con fughe tra telaio fisso e mobile di 5 mm. mentre all'interno il piano delle ante apribili avrà una sporgenza (sormonto) di 10 mm. rispetto al piano del telaio fisso.

I fermavetri saranno a scatto, con opportune sedi per l'inserimento delle guarnizioni di tenuta del vetro.

Gli accessori e le guarnizioni dovranno essere quelli originali, studiati e prodotti per questo sistema di profilati.

Per quanto riguarda la tenuta all'aria, all'acqua ed al vento i serramenti dovranno garantire le seguenti classi di tenuta per le portabalcone ad una e due ante:

Permeabilità all'aria:	classe 4	UNI EN 1026	UNI EN 12207
Tenuta all'acqua:	classe E1500	UNI EN 1027	UNI EN 12208
Resistenza al vento:	classe C5	UNI EN 12221	UNI EN 12210

L'ottenimento delle caratteristiche di tenuta sopracitate con questi profilati dovrà essere dimostrabile con riproduzione in copia dei risultati del collaudo presso idoneo Istituto, effettuato dal costruttore dei serramenti o, in mancanza, dal produttore dei profilati.

Finitura superficiale dei profilati in alluminio

La protezione e la finitura delle superfici dei profilati dovranno essere effettuate mediante anodizzazione o verniciatura.

- L'anodizzazione, nel colore _____ dovrà essere eseguita secondo quanto previsto dal marchio europeo "EURAS-EWAA / QUALANOD".
- La verniciatura, nel colore _____ secondo tabelle RAL dovrà essere eseguita in base a quanto previsto dal marchio europeo "QUALICOAT".

LIMITI DI IMPIEGO

Il progettista o il serramentista, in fase di determinazione delle dimensioni massime dei serramenti dovrà considerare e valutare oltre alle dimensioni ed alle inerzie dei profilati, anche i fattori inerenti alla posa e alle caratteristiche meteorologiche, quali l'altezza dal suolo, l'esposizione alla pioggia e la velocità dei venti presenti nella zona. Per la conoscenza e l'utilizzo di questi dati, consigliamo di consultare e seguire quanto indicato sulle "Raccomandazioni UNCSAAL" elaborate sulla base delle norme UNI, UNI-EN ed UNI-CNR esistenti in merito.

DESCRIZIONE TECNICA SISTEMA DOGMA PRO

DOGMA PRO, é un sistema per la costruzione di serramenti marcabili nostri Sistemi in Alluminio a taglio termico.



rappresenta la punta di diamante dei

La grande sezione ed il taglio termico da 44 mm per il telaio e 40 mm per l'anta rendono questo Sistema ideale per l'edilizia privata, ma anche per uffici e strutture dove è importante raggiungere elevate tenute (grazie al sistema di guarnizioni a giunto aperto) ed alto isolamento termico, anche su serramenti di grandi dimensioni.

DOGMA PRO permette l'alloggiamento di vetri con camere di grande spessore o con veneziane interne.

Il sistema è completo sotto ogni aspetto: profilati, accessori e finiture superficiali.

Pertanto si presta alla realizzazione delle più svariate tipologie, vetrine e serramenti con anta scorrevole in parallelo.

DOGMA PRO utilizza accessori per camera europea o pista 16 int.9mm, che consentono un'ampia scelta di soluzioni e all'occorrenza facilità di manutenzione, garantendo all'utente finale la totale soddisfazione.

TIPO DI SISTEMA :	Sormonto interno - Complanare esterno
PROFILATI ESTRUSI :	Lega d'alluminio 6060 Al Mg 0.5, Si 0.4, Fe 0.2 secondo le norme UNI EN 573
STATO DI FORNITURA :	T6 secondo la norma UNI EN 515 (equivalente TA 16)
TOLLERANZE DIMENSIONALI E SPESSORI :	UNI EN 12020.2 e/o UNI EN 755-9
SISTEMA DI TENUTA ARIA, ACQUA E VENTO :	
FINESTRE E PORTEFINESTRE :	Giunto Aperto a camera europea e/o ferramenta perimetrale con guarnizione centrale
PORTE :	Con doppia guarnizione di battuta
TAGLIO TERMICO :	Con barrette complanari in poliammide da mm 44-40
DIMENSIONI DEL SISTEMA :	Telaio fisso sezione mm 75 Telaio anta sezione mm 85 Inserimento vetri variabile tra 18 e 65 mm
ALTEZZA SEDE VETRO :	mm 22
INSERIMENTO VETRO :	Fermavetro sia rettangolare che arrotondato o sgusciato (aggancio a scatto, con molletta oppure a contrasto) Profili vetro ad infilo normali e maggiorati di vario design
GUARNIZIONI :	In gomma sintetica, EPDM - TPE - GOMMA SILICONICA
CERTIFICAZIONI :	ISTEDIL di Guidonia (RM) Rapporto di Prova contattare Ufficio Tecnico. Permeabilità all'aria (UNI EN 1026, UNI EN 12207): Classe 4 Tenuta all'acqua (UNI EN 1027, UNI EN 12208): Classe E1500 Resistenza al vento (UNI EN 12221, UNI EN 12210): Classe C5 Altri certificati del sistema sono a disposizione.
TRASMITTANZA TERMICA :	Uf variabile secondo la configurazione adottata, come da calcoli eseguiti da IRCCOS di Samarate (VA) nel pieno rispetto delle norme UNI EN 10077-1 e UNI EN 10077-2. Per certificati contattare l'Ufficio Tecnico.
MARCATURA CE :	Come previsto da norma UNI EN 14351-1+A1:2010 Cascading disponibile

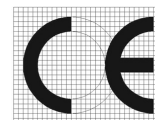

Uw SERRAMENTO CAMPIONE DOGMA PRO

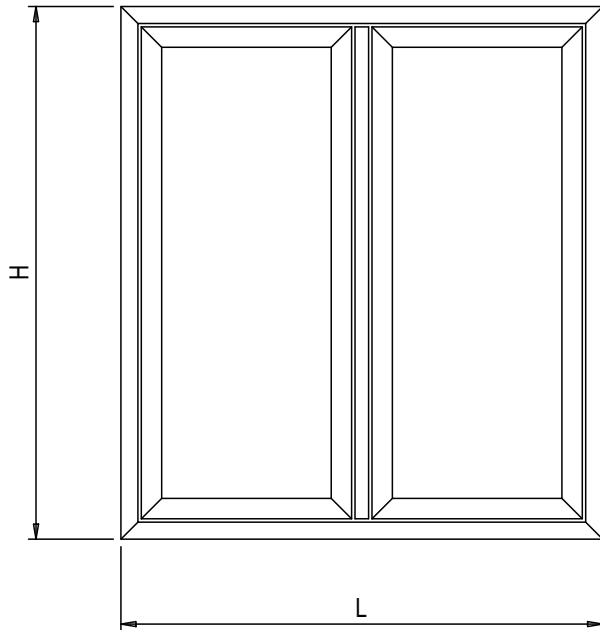

Uw = 1.18 W/m²K

VETRO DI Ug = 1.0 W/m²K CERTIFICATO
CON CANALINA CALDA psi = 0.036 W/mK

L : 1535 mm

H : 1480 mm

Dimensioni ammesse per il calcolo Uw su serramento campione fino a 2.3 m² dalla norma UNI EN 14351-1 + A1:2010

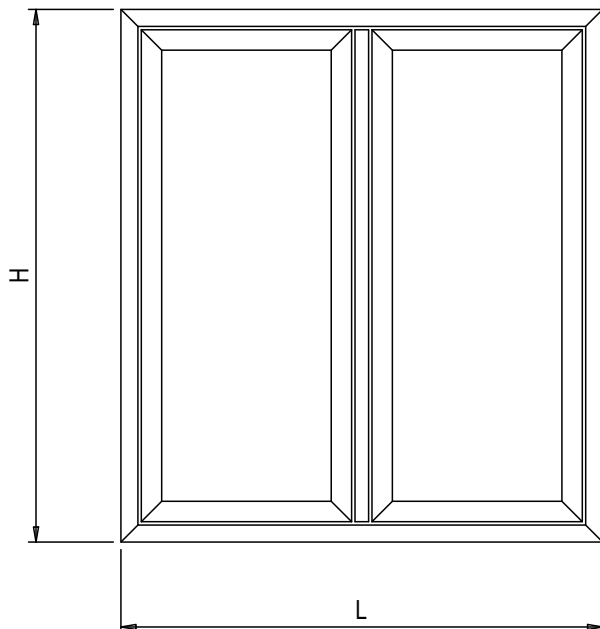

Uw = 0.89 W/m²K

VETRO DI Ug = 0.6 W/m²K CERTIFICATO
CON CANALINA CALDA psi = 0.031 W/mK

L : 1535 mm

H : 1480 mm

Marcabili  come previsto da norma UNI EN 14351-1+A1:2010, cascading disponibile.

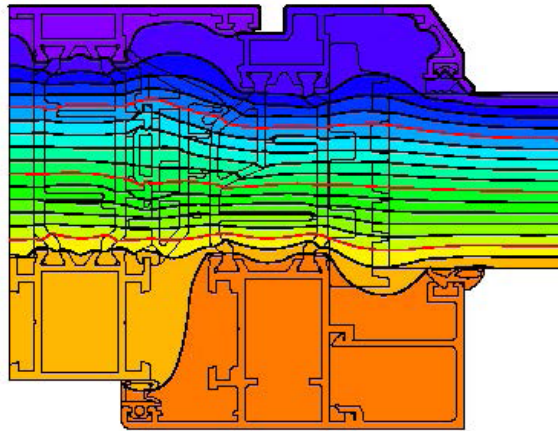

$$U_f = 1.2 \text{ W/m}^2\text{K}$$

CERTIFICATO IRcCOS
N° 1994-CPR-RP2202 del 01.03.2021

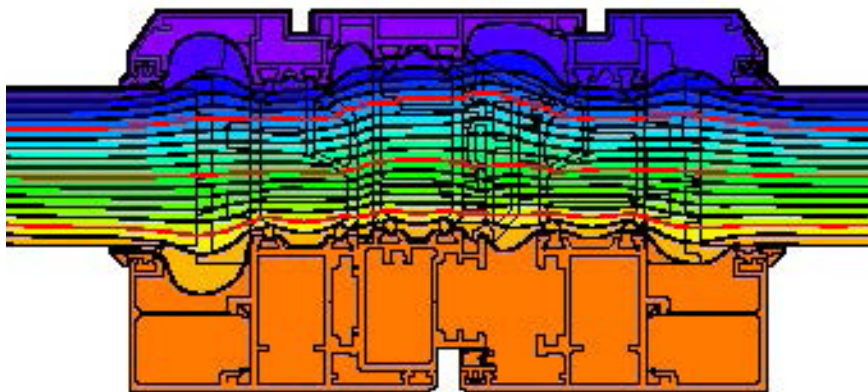

$$U_f = 1.2 \text{ W/m}^2\text{K}$$

CERTIFICATO IRcCOS
N° 1994-CPR-RP2202 del 01.03.2021



PERMEABILITA' ALL'ARIA SECONDO NORME EN 1026 EN 12207

Classe ottenuta dalla finestra campione DOGMA	1	2	3	4
---	---	---	---	----------

LA CLASSE OTTENUTA DAL SERRAMENTO INDICA CHE ALLA PRESSIONE DI PROVA PARI A 600 PASCAL IL VOLUME D'ARIA FILTRATA ALL'INTERNO E' IL MINORE POSSIBILE. LA SCALA DI BEAUFORT DI CLASSIFICAZIONE DEL VENTO INDICA CHE 600 PASCAL CORRISPONDONO AD UN VENTO DI CIRCA 110km/h (TEMPESTA VIOLENTA).



TENUTA ALL'ACQUA SECONDO NORME EN 1027 EN 12208

Classe ottenuta dalla finestra campione DOGMA	1A	2A	3A	4A	5A	6A	7A	8A	9A	E1500
---	----	----	----	----	----	----	----	----	----	--------------

LA CLASSE OTTENUTA DAL SERRAMENTO SOTTOPOSTO A TEST INDICA CHE NON SI SONO VERIFICATE INFILTRAZIONI D'ACQUA ALL'INTERNO FINO ALLA PRESSIONE DI 1500 PASCAL LA QUANTITA' D'ACQUA UTILIZZATA PER IL TEST E' QUELLA PREVISTA PER SERRAMENTI TOTALMENTE ESPOSTI (A)



RESISTENZA AL VENTO SECONDO NORME EN 12211 EN 12210

Classe della pressione di prova	1	2	3	4	5
Classe di flessione ottenuta finestra campione DOGMA	A	B	C		

LA CLASSE C5 OTTENUTA DAL SERRAMENTO INDICA CHE ESSO, SOTTOPOSTO A 50 CICLI RIPETUTI DI PRESSIONE DI +1000 E - 1000 PASCAL ED ALLA PRESSIONE DI SICUREZZA DI 3000 PASCAL, NON HA RIPORTATO ALCUN DANNO ALLA FUNZIONALITA'. INDICA INOLTRE CHE LA FRECCIA MASSIMA DI INFLESSIONE NON HA SUPERATO 1/300 DELL'ALTEZZA.

TIPOLOGIE REALIZZABILI

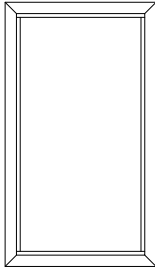

FISSO

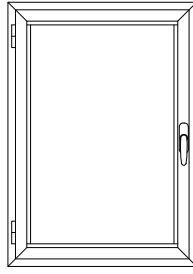

1 ANTA AP. INTERNA

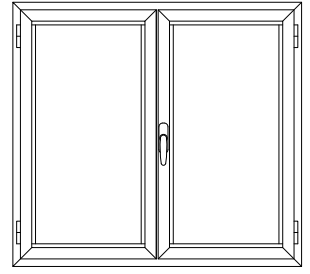

2 ANTE AP. INTERNA Z-RIP-Z

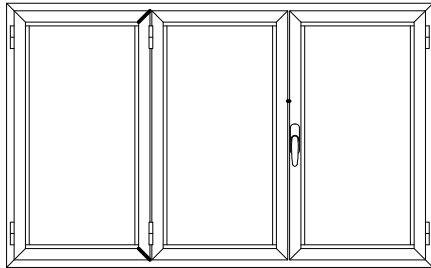

3 ANTE AP. INTERNA Z-RIP-Z

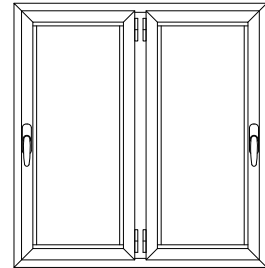

2 ANTE MONTANTE CENTRALE

TIPOLOGIE REALIZZABILI

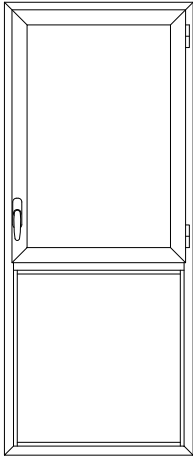

ANTA A SCOMPARSA
CON SOTTOLUCE FISSO

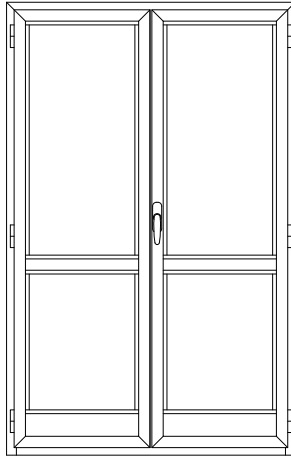

PORTABALCONE CON SOGLIA RIBASSATA

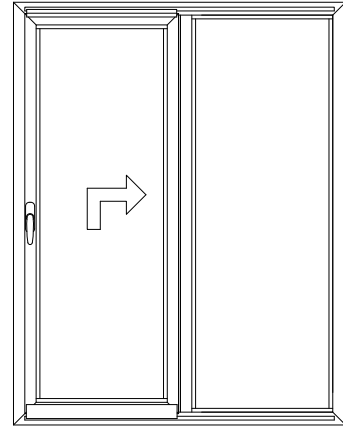

SCORREVOLE PARALLELO

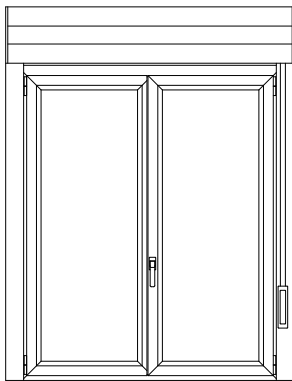

MONOBLOCCO 2 ANTE

TIPOLOGIE REALIZZABILI

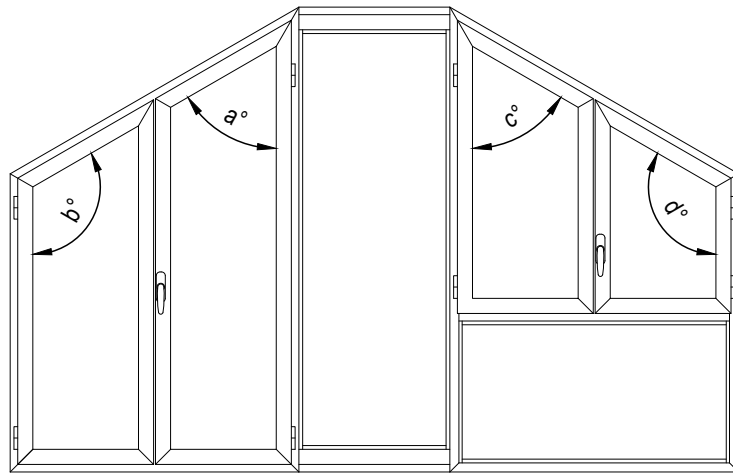

SERRAMENTI FUORI SQUADRO COMBINATI

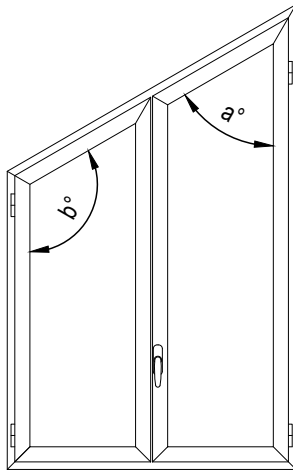

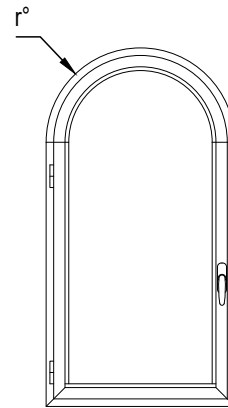

SERRAMENTI FUORI SQUADRO









SERRAMENTI CURVI

IN CASO DI REALIZZAZIONE DI SERRAMENTI FUORI SQUADRO O DI SERRAMENTI CURVI OCCORRE VERIFICARE ATTENTAMENTE , ANCHE IN FUNZIONE DELLA TIPOLOGIA DI APERTURA (BATTENTE , WASISTAS , BILICO , SPORGERE) , CHE LE CARATTERISTICHE GEOMETRICHE E LE DIMENSIONI (ANGOLO DI INCLINAZIONE , RAGGIATURA DELLA PARTE CURVA , ACCESSORISTICA UTILIZZATA) CONSENTANO IL CORRETTO SVINCOLO DELLE PARTI MOBILI.

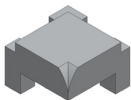
- Elenco Accessori 
- Elenco Guarnizioni 
- Elenco Attrezzature 

LE IMMAGINI SONO INDICATIVE E NON IMPEGNATIVE

SAGOMA	ARTICOLO	MATERIALE / COLORE	DESCRIZIONE
	G101	NYLON	CAPPETTA PER DRENAGGIO ACQUA
		VARI	SCATOLA DA : 1000 Pz.
	G112	ACCIAIO	SQUADRETTA ALLINEAMENTO ALETTE
		INOX	SCATOLA DA : 1000 Pz.
	G197	ALLUMINIO	VITE AGGIUNTIVA PER CAVALLOTTO TS083
		GREZZO	SCATOLA DA : 100 Pz.
	G199	ALLUMINIO	CAVALLOTTO PER TRAVERSI 175020 - 175041
		GREZZO	SCATOLA DA : 100 Pz.
	G218	ALLUMINIO	SPINA DIAMETRO 8 PER CAVALLOTTO INTERNO ART. G199 - TS083
		GREZZO	SCATOLA DA : 400 Pz.
	G220	ALLUMINIO	SQUADRETTA DI ALLINEAMENTO COPRIFILI 40113 - 40114
		GREZZO	SCATOLA DA : 100 Pz.

SAGOMA	ARTICOLO	MATERIALE / COLORE	DESCRIZIONE
	G231	ALLUMINIO	ANGOLO PER FERMAVETRI ARROTONDATI SCATOLA DA : 100 Pz.
		VARI	
	G255	NYLON	SQUADRETTA DI ALLINEAMENTO COPRIFILO 40245 SCATOLA DA : 50 Pz.
		NERO	
	G266	ZAMA	SPINA 3 mm A FRATTURA PROGRAMMATA PER SQUADRETTI TUBOLARITÀ ESTERNA ART. TS079 - TS081 SCATOLA DA : 400 Pz.
		GREZZO	
	G268	ALLUMINIO	SQUADRETTA DI ALLINEAMENTO 15.9 x 1 mm PER ANTE/TELAJ DA SCATOLA DA : 50 Pz.
		GREZZO	
	G269	ALLUMINIO	SQUADRETTA DI ALLINEAMENTO DA 14.4 x 1 mm PER ANTE/TELAJ SCATOLA DA : 50 Pz.
		GREZZO	
	G501N	ALLUMINIO	SQUADRETTA DI ALLINEAMENTO A CAMME \ CAVALLOTTO PER TRAVERSI SCATOLA DA : 250 Pz.
		GREZZO	

SAGOMA	ARTICOLO	MATERIALE / COLORE	DESCRIZIONE
	G2001	ALLUMINIO	VITE PER SQUADRETTA AD ESPANSIONE
		GREZZO	SCATOLA DA : 300 Pz.
	G2002	ALLUMINIO	SPINA PER SQUADRETTA AD ESPANSIONE
		GREZZO	SCATOLA DA : 300 Pz.
	G2007	ALLUMINIO	SQUADRETTA AD ESPANSIONE PER TUBOLARITÀ MAGGIORATA ART. 175016 - 175064
		GREZZO	SCATOLA DA : 100 Pz.
	G2009	ALLUMINIO	VITE MAGGIORATA PER SQUADRETTA AD ESPANSIONE TS080
		GREZZO	SCATOLA DA : 300 Pz.
	GT118	NYLON	TAPPI PER GOCCIOLATOIO UNIVERSALE ART. 40269
		NERO	SCATOLA DA : 25 Pz.
	GT131	NYLON	TAPPI PER CASSONETTO PROFILATI 1184 - 1185
		NERO	SCATOLA DA : 70 Pz.

SAGOMA	ARTICOLO	MATERIALE / COLORE	DESCRIZIONE
	GT132	NYLON	TAPPI INVITO TAPPARELLA PROFILATO 40038 SCATOLA DA : 500 Pz.
		NERO	
	GT134	NYLON	CLIP AGGANCIAMENTO FERMAVETRI SCATOLA DA : 200 Pz.
		BIANCO	
	S3001	ACCIAIO INOX	SPINA 3 mm A FRATTURA PROGRAMMATA PER SQUADRETTE TUBOLARITÀ ESTERNA ART. TS079 - TS081 SCATOLA DA : 400 Pz.
		GREZZO	
	TA075	NYLON	REGOLO CAMERA SEMPLICE SCATOLA DA : 200 Pz.
		NERO	
	TA076	NYLON	REGOLO CAMERA MAGGIORATA SCATOLA DA : 200 Pz.
		NERO	
	TA1000	NYLON	MOLLETTA RITEGNO IMBOTTE SCATOLA DA : 50 Pz.
		NERO	

SAGOMA	ARTICOLO	MATERIALE / COLORE	DESCRIZIONE
	TS073	ALLUMINIO	CAVALLOTTO ESTERNO PER TRAVERSI STANDARD
		GREZZO	SCATOLA DA : 100 Pz.
	TS074	ALLUMINIO	CAVALLOTTO ESTERNO PER TRAVERSI MAGGIORATI
		GREZZO	SCATOLA DA : 100 Pz.
	TS077	ALLUMINIO	SQUADRETTA A PULSANTE PER TUBOLARITÀ INTERNA STANDARD
		GREZZO	SCATOLA DA : 250 Pz.
	TS078	ALLUMINIO	SQUADRETTA AD ESPANSIONE PER TUBOLARITÀ INTERNA STANDARD
		GREZZO	SCATOLA DA : 200 Pz.
	TS079	ALLUMINIO	SQUADRETTA A CIANFRINARE\SPINARE PER TUBOLARITÀ ESTERNA STANDARD
		GREZZO	SCATOLA DA : 200 Pz.
	TS080	ALLUMINIO	SQUADRETTA A CIANFRINARE\SPINARE\AVVITARE AD ESPANSIONE PER TUBOLARITÀ INTERNA MAGGIORATA
		GREZZO	SCATOLA DA : 150 Pz.

SAGOMA	ARTICOLO	MATERIALE / COLORE	DESCRIZIONE
	TS081	ALLUMINIO	SQUADRETTA A CIANFRINARE\SPINARE PER TUBOLARITÀ ESTERNA MAGGIORATA SCATOLA DA : 250 Pz.
		GREZZO	
	TS082	ALLUMINIO	PLACCHETTA DI COMPENSAZIONE PER G501N CAVALLOTTO TRAVERSI SU ANTE SGUSCIATE E ARROTONDATE SCATOLA DA : 50 Pz.
		GREZZO	
	TS083	ALLUMINIO	CAVALLOTTO INTERNO PER TRAVERSI MAGGIORATI FASCE E ZOCCOLI SCATOLA DA : 100 Pz.
		GREZZO	
	TS084	ALLUMINIO	SQUADRETTA TUBOLARITÀ ESTERNA ANTA A SCOMPARSA ART. 175047 SCATOLA DA : 40 Pz.
		GREZZO	
	TS088	ALLUMINIO	CAVALLOTTO ESTERNO PER FASCE E ZOCCOLI SCATOLA DA : 100 Pz.
		GREZZO	
	TS1001	ALLUMINIO	SQUADRETTA DI ALLINEAMENTO PER TELAI E IMBOTTI SCATOLA DA : 250 Pz.
		GREZZO	

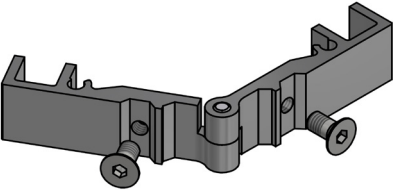
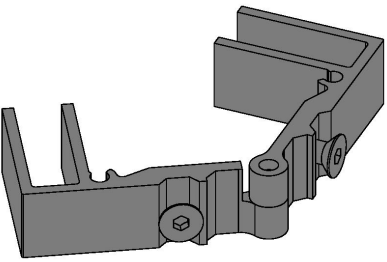
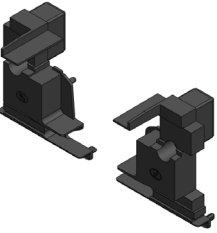
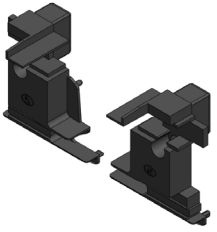
SAGOMA	ARTICOLO	MATERIALE / COLORE	DESCRIZIONE
	TS085	ALLUMINIO	SQUADRETTA ANGOLO VARIABILE PROFILATI STANDARD
		GREZZO	SCATOLA DA : 25 Pz.
	TS093	ALLUMINIO	SQUADRETTA ANGOLO VARIABILE PROFILATI MAGGIORATI
		GREZZO	SCATOLA DA : 25 Pz.
	TT085	NYLON	TAPPO RIPORTO CENTRALE ART. 175003 - 175017
		NERO	SCATOLA DA : 24 Pz.
	TT086	NYLON	TAPPO RIPORTO CENTRALE ART. 175018 - 175065 PISTA 16 INT 9 mm
		NERO	SCATOLA DA : 24 Pz.

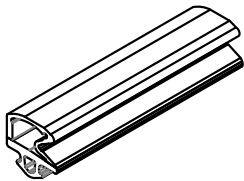
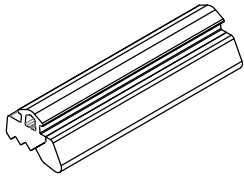
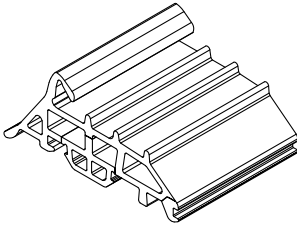
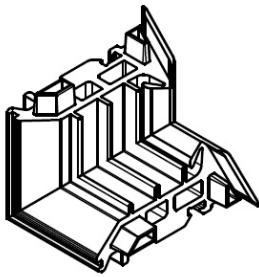
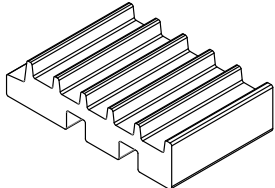
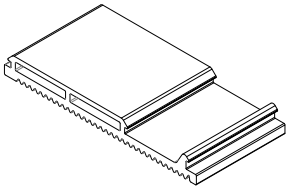
SAGOMA	ARTICOLO	MATERIALE / COLORE	DESCRIZIONE
	TG031	E.P.D.M. + ESPANSO	GUARNIZIONE DI BATTUTA INTERNA SCATOLA DA : 200 ml
		NERO	
	TG032	E.P.D.M. + ESPANSO	GUARNIZIONE CINGIVETRO ESTERNA DA 3 mm SCATOLA DA : 250 ml
		NERO	
	TG185	E.P.D.M. + ESPANSO	GUARNIZIONE DI TENUTA CENTRALE IN DOPPIA DENSITÀ SCATOLA DA : 50 ml
		NERO	
	TG186	E.P.D.M.	ANGOLO VULCANIZZATO PER GUARNIZIONE TG185 APERTURA INTERNA SCATOLA DA : 40 Pz.
		NERO	
	TG385	PEX	GUARNIZIONE SOTTOVETRO ISOLANTE SCATOLA DA : 100 ml
		GRIGIO	
	TG302	E.P.D.M.	GUARNIZIONE ISOLANTE SCATOLA DA : 30 ml
		NERO	

SAGOMA	ARTICOLO	MATERIALE / COLORE	DESCRIZIONE
	TG304	E.P.D.M.	GUARNIZIONE INTERNA CINGIVETRO DA 3 mm A 4 mm
		NERO	SCATOLA DA : 600 ml
	TG305	E.P.D.M.	GUARNIZIONE INTERNA CINGIVETRO DA 5 mm A 6 mm
		NERO	SCATOLA DA : 320 ml
	TG306	E.P.D.M.	GUARNIZIONE INTERNA CINGIVETRO DA 7 mm A 8 mm
		NERO	SCATOLA DA : 200 ml

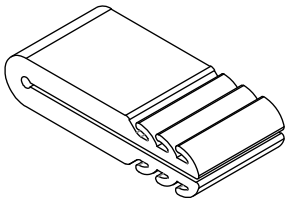
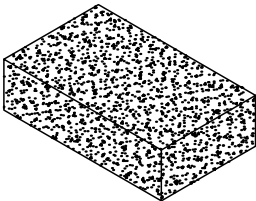
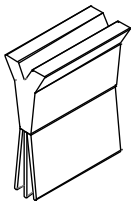
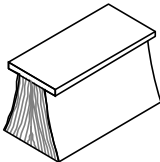
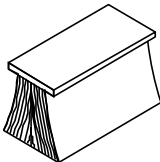
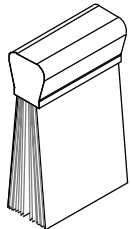

SAGOMA	ARTICOLO	MATERIALE / COLORE	DESCRIZIONE
	Z130	E.P.D.M.	GUARNIZIONE GIUNTO ACCOPPIAMENTO NASTRI SCATOLA DA : 60 ml
		NERO	
	Z119	POLIURETANO	GUARNIZIONE ISOLANTE SCATOLA DA : 10 ml
		GRIGIO	
	Z600	PVC + ELAPRENE	GUARNIZIONE PER SOTTOPORTE SCATOLA DA : 300 ml
		NERO	
	Z601	SPAZZOLINO	SPAZZOLINO 4.8 x 15 SCATOLA DA : 275 ml
	Z602	SPAZZOLINO	SPAZZOLINO PER CIELINO CASSONETTO 6.9 x 14 SCATOLA DA : 150 ml
	Z803	SPAZZOLINO	SPAZZOLINO CON SUPPORTO ZINCATO 31.8mm SCATOLA DA : 400 ml

SAGOMA	ARTICOLO	MATERIALE / COLORE	DESCRIZIONE
	Z804	SPAZZOLINO	SPAZZOLINO 4.8 x 11
			SCATOLA DA : 400 ml
	Z805	E.P.D.M.	COPRICAVA A SCATTO PER CAVA CAMERA EUROPEA
		NERO	SCATOLA DA : 300 ml
	Z801	ALLUMINIO	PROFILATO UNIVERSALE PORTASPAZZOLINO
		GREZZO	SCATOLA DA : 2.5 ml

SAGOMA	ARTICOLO	MATERIALE / COLORE	DESCRIZIONE
			COLLANTE MONOCOMPONENTE REATTIVO ALL'UMIDITÀ PER INCOLLAGGIO ANGOLI
	GA028	MISCELLANEA	RUOTA INFILA-GUARNIZIONE TG185 SCATOLA DA : 1 ml
	GA112	ALLUMINIO	DIMA FORO 3mm PER CAVALLOTTO ESTERNO TRAVERSI SCATOLA DA : 1 Pz
	GA065	MISCELLANEA	CIANFRINATRICE MANUALE UTILIZZARE COLTELLI DA 3mm SCATOLA DA : 1 Pz.

SAGOMA	ARTICOLO	MATERIALE / COLORE	DESCRIZIONE
	GFDP1	ACCIAIO	GRUPPO FRESA PER LAVORAZIONE TRAVERSI\FASCE\ZOCOLI PER UNIONE CON TELAIO SCATOLA DA : NO MAGAZZINO
		GREZZO	
	GFDP2	ACCIAIO	GRUPPO FRESA PER LAVORAZIONE TRAVERSI\FASCE\ZOCOLI PER UNIONE CON ANTE SGUSCIATE O ARROTONDATE SCATOLA DA : NO MAGAZZINO
		GREZZO	
	GFDP3	ACCIAIO	GRUPPO FRESA PER LAVORAZIONE TRAVERSI\FASCE\ZOCOLI PER UNIONE CON ANTE PIANE SCATOLA DA : NO MAGAZZINO
		GREZZO	

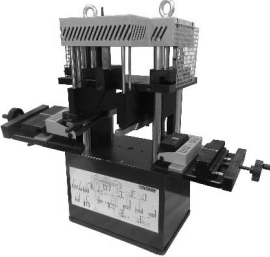
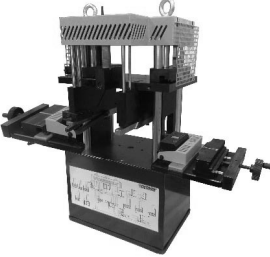
PUNZONATRICI ESISTENTI LAVORAZIONI ESEGUITE

	<p style="text-align: center;">GA101 + GA136</p>	<p style="text-align: center;">LAVORAZIONI :</p> <ol style="list-style-type: none"> 1 - FORO D.8mm PER SQUAD. INT. MULTIF. 2 - FORO D.8mm PER SQUAD. INT. A PULSANTE 3 - CAVALLOTTO INTERNO 4 - AERZIONE VETRO 5 - SCARICO ACQUA 6 - CREMONESE 7 - FORATURA ASTA DI COMANDO 8 - ASPORTAZIONE DENTINI PASS. ASTINA 9 - FORO D.3mm PER SQUAD. ESTERNA
	<p style="text-align: center;">GA100 + GA037 GA039 GA136</p>	<p style="text-align: center;">LAVORAZIONI :</p> <ol style="list-style-type: none"> 1 - FORO D.8mm PER SQUAD. INT. MULTIF. 2 - FORO D.8mm PER SQUAD. INT. A PULSANTE 3 - CAVALLOTTO INTERNO 4 - AERZIONE VETRO 5 - SCARICO ACQUA 6 - CREMONESE 7 - FORATURA ASTA DI COMANDO 8 - ASPORTAZIONE DENTINI PASS. ASTINA 9 - FORO D.3mm PER SQUAD. ESTERNA
	<p style="text-align: center;">GA003 + GA037 GA039 GA082 GA083C GA136</p>	<p style="text-align: center;">LAVORAZIONI :</p> <ol style="list-style-type: none"> 1 - FORO D.8mm PER SQUAD. INT. MULTIF. 2 - FORO D.8mm PER SQUAD. INT. A PULSANTE 3 - CAVALLOTTO INTERNO 4 - AERZIONE VETRO 5 - SCARICO ACQUA 6 - CREMONESE 7 - FORATURA ASTA DI COMANDO 8 - ASPORTAZIONE DENTINI PASS. ASTINA 9 - FORO D.3mm PER SQUAD. ESTERNA

GA037 - GA039 - GA082 - GA083C - GA136 : ATTREZZATURE COMPLEMENTARI





GA003 - GA100 - GA101 : PUNZONATRICI NON PIÙ COMMERCIALIZZATE

PUNZONATRICI ESISTENTI ELENCO ATTREZZATURE

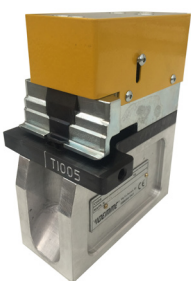
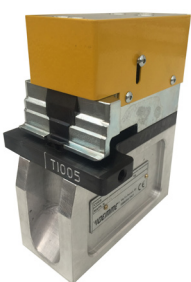

	GA136	MISCELLANEA	PUNZONATRICE PER FORO 3 mm SQUADRETTA ESTERNA SCATOLA DA : 1 Pz.
		GA037	MISCELLANEA
	GA039		PVC
		GA082	MISCELLANEA
	GA083C		MISCELLANEA

ABACO TRACIANTI

SAGOMA	ARTICOLO	MATERIALE / COLORE	DESCRIZIONE
	TI001	MISCELLANEA	<p style="text-align: center;">TRACIANTE FORO D.8 mm + ASOLA PER SQUADRETTE INTERNE PER TELAI E ANTE</p> <p>SCATOLA DA : 1 Pz.</p>
		UTILIZZARE CON UNITÀ DI SPINTA DA ACQUISTARE SEPARATAMENTE	
	TI002	MISCELLANEA	<p style="text-align: center;">TRACIANTE FORO D.10,5 mm PER CAVALLOTTI INTERNI</p> <p>SCATOLA DA : 1 Pz.</p>
		UTILIZZARE CON UNITÀ DI SPINTA DA ACQUISTARE SEPARATAMENTE	
	TI003	MISCELLANEA	<p style="text-align: center;">TRACIANTE FORO D.3 mm PER SQUADRETTA ESTERNA PER TELAI E ANTA</p> <p>SCATOLA DA : 1 Pz.</p>
		UTILIZZARE CON UNITÀ DI SPINTA DA ACQUISTARE SEPARATAMENTE	
	TI004	MISCELLANEA	<p style="text-align: center;">TRACIANTE CREMONESE, SPUNTATURA ALETTE E ASTINA</p> <p>SCATOLA DA : 1 Pz.</p>
		UTILIZZARE CON UNITÀ DI SPINTA DA ACQUISTARE SEPARATAMENTE	
	TI005	MISCELLANEA	<p style="text-align: center;">TRACIANTE ASOLA 26,5 x 10.1 PER SCARICO ACQUA</p> <p>SCATOLA DA : 1 Pz.</p>
		UTILIZZARE CON UNITÀ DI SPINTA DA ACQUISTARE SEPARATAMENTE	
	TI006	MISCELLANEA	<p style="text-align: center;">TRACIANTE ASOLA 20x3 mm PER SCARICO CONDENSA</p> <p>SCATOLA DA : 1 Pz.</p>
		UTILIZZARE CON UNITÀ DI SPINTA DA ACQUISTARE SEPARATAMENTE	





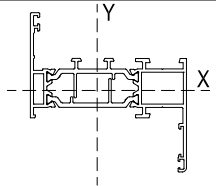
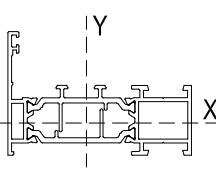
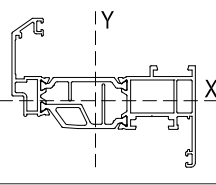
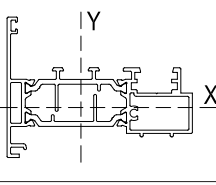
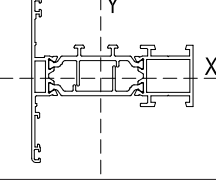
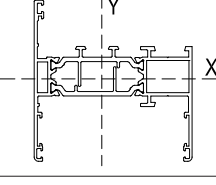
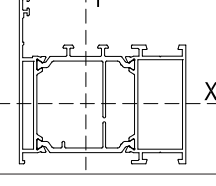
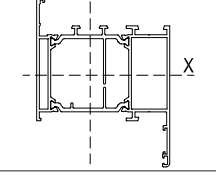
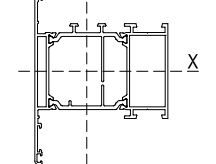

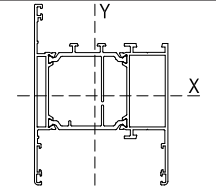
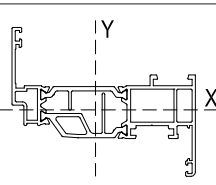
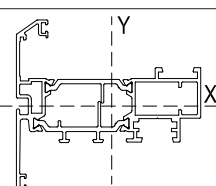
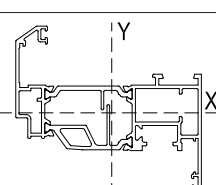
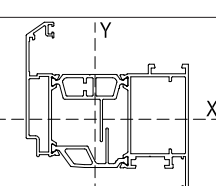
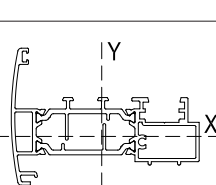
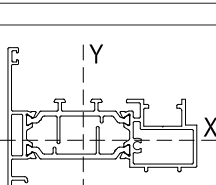
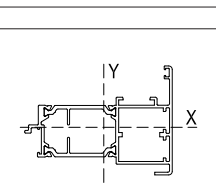
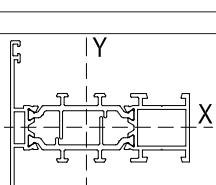
Profilati ed Inerzie

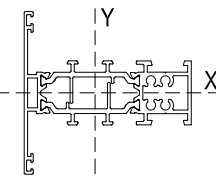
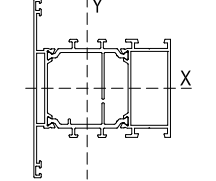
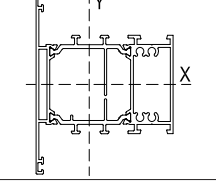
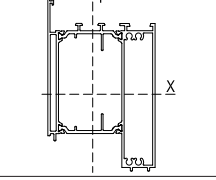
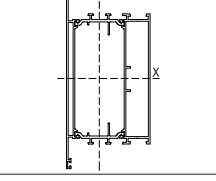
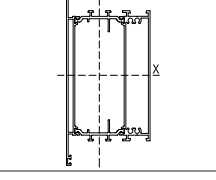
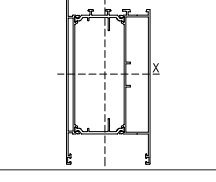
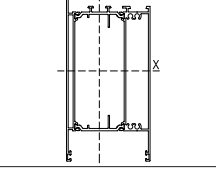
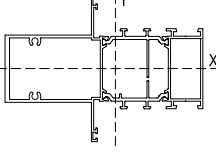
 SAGOMA	ARTICOLO	INERZIA	MODULO	DESCRIZIONE
	PESO (Kg/m)	cm ⁴	cm ³	
	175000	J_x 7.7	W_x 2.1	TELAIO Z TUBOLARITÀ STANDARD (PAG. 4.2)
	1.358	J_y 30.8	W_y 7.7	
	175001	J_x 4.9	W_x 1.4	TELAIO L TUBOLARITÀ STANDARD (PAG. 4.2)
	1.231	J_y 25.2	W_y 6.3	
	175002	J_x 8.4	W_x 2.1	ANTA Z SGUSCIATA TUBOLARITÀ STANDARD (PAG. 4.12)
	1.549	J_y 37.8	W_y 8.4	
	175003	J_x 6.3	W_x 2.1	RIPORTO CENTRALE PIANO (PAG. 4.25)
	1.387	J_y 30.8	W_y 6.3	
	175004	J_x 7.7	W_x 2.1	TELAIO T TUBOLARITÀ STANDARD (PAG. 4.3)
	1.367	J_y 28.7	W_y 6.3	
	175005	J_x 10.5	W_x 2.8	TELAIO H TUBOLARITÀ STANDARD (PAG. 4.3)
	1.494	J_y 34.3	W_y 8.4	
	175006	J_x 21.7	W_x 4.9	TELAIO L TUBOLARITÀ MAGGIORATA (PAG. 4.7)
	1.649	J_y 35.0	W_y 8.4	
	175007	J_x 28.0	W_x 4.9	TELAIO Z TUBOLARITÀ MAGGIORATA (PAG. 4.7)
	1.749	J_y 40.6	W_y 10.5	
	175008	J_x 28.0	W_x 5.6	TELAIO T TUBOLARITÀ MAGGIORATA (PAG. 4.8)
	1.784	J_y 39.2	W_y 9.1	

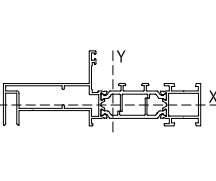
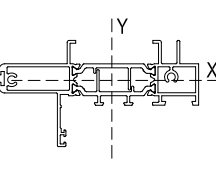
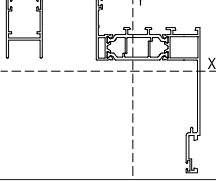
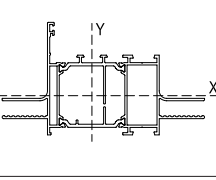
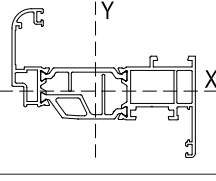
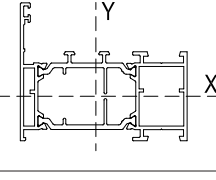
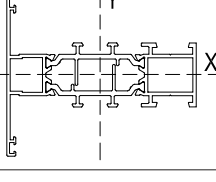
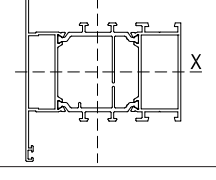
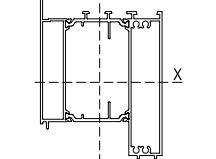
 SAGOMA	ARTICOLO	INERZIA	MODULO	DESCRIZIONE
	PESO (Kg/m)	cm ⁴	cm ³	
	175009	J_x 33.6	W_x 6.3	TELAIO H TUBOLARITÀ MAGGIORATA (PAG. 4.8)
	1.884	J_y 44.1	W_y 10.5	
	175010	J_x 7.0	W_x 2.1	ANTA Z PIANA TUBOLARITÀ STANDARD (PAG. 4.13)
	1.454	J_y 37.1	W_y 8.4	
	175011	J_x 11.9	W_x 2.8	ANTA T SGUSCIATA TUBOLARITÀ STANDARD (PAG. 4.24)
	1.699	J_y 40.6	W_y 8.4	
	175012	J_x 11.9	W_x 2.8	ANTA Z SGUSCIATA PISTA 16 TUBOLARITÀ STANDARD (PAG. 4.14)
	1.680	J_y 41.3	W_y 9.8	
	175014	J_x 30.8	W_x 6.3	ANTA Z SGUSCIATA TUBOLARITÀ MAGGIORATA (PAG. 4.15)
	2.016	J_y 50.4	W_y 11.2	
	175017	J_x 7.0	W_x 2.1	RIPORTO CENTRALE ARROTONDATO (PAG. 4.25)
	1.440	J_y 33.6	W_y 7.0	
	175018	J_x 6.3	W_x 2.1	RIPORTO CENTRALE PIANO PISTA 16 (PAG. 4.26)
	1.395	J_y 30.8	W_y 6.3	
	175019	J_x 8.4	W_x 2.8	RIPORTO BILICO (PAG. 4.28)
	1381	J_y 31.5	W_y 7	
	175020	J_x 7.0	W_x 2.1	TRAVERSO CON CAVALOTTI TUBOLARITÀ STANDARD (PAG. 4.29)
	1.338	J_y 27.3	W_y 6.3	

 SAGOMA	ARTICOLO	INERZIA	MODULO	DESCRIZIONE
	PESO (Kg/m)	cm ⁴	cm ³	
	175021	J_x 7.0	W_x 2.1	TRAVERSO CON VITI TUBOLARITÁ STANDARD (PAG. 4.29)
	1.507	J_y 30.8	W_y 7.7	
	175022	J_x 26.6	W_x 5.6	TRAVERSO CON CAVALOTTI TUBOLARITÁ MAGGIORATA (PAG. 4.30)
	1.756	J_y 37.1	W_y 9.1	
	175023	J_x 28.0	W_x 5.6	TRAVERSO CON VITI TUBOLARITÁ MAGGIORATA (PAG. 4.30)
	1.926	J_y 40.6	W_y 9.8	
	175024	J_x 86.1	W_x 14.0	ZOCCOLO RIPORTATO (PAG. 4.32)
	2.450	J_y 53.2	W_y 13.3	
	175025	J_x 168.0	W_x 21.0	FASCIA CON CAVALLOTTI (PAG. 4.33)
	3.005	J_y 67.2	W_y 18.9	
	175026	J_x 175.0	W_x 21.7	FASCIA CON VITI (PAG. 4.34)
	3.031	J_y 66.5	W_y 16.1	
	175027	J_x 172.2	W_x 21.7	ZOCCOLO CON CAVALLOTTI (PAG. 4.35)
	3.013	J_y 70.7	W_y 17.5	
	175028	J_x 180.6	W_x 22.4	ZOCCOLO CON VITI (PAG. 4.36)
	3.117	J_y 72.1	W_y 18.2	
	175029	J_x 35.7	W_x 7.0	PILASTRINO (PAG. 4.44)
	2.649	J_y 137.9	W_y 20.3	

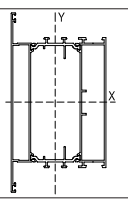
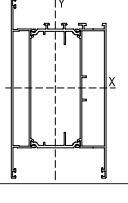
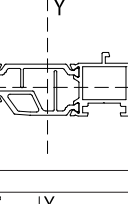
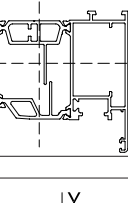
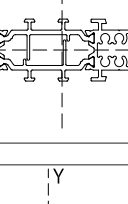
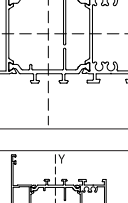
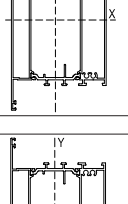
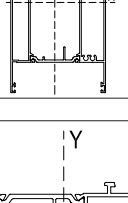
 SAGOMA	ARTICOLO	INERZIA	MODULO	DESCRIZIONE
	PESO (Kg/m)	cm ⁴	cm ³	
	175030	J_x 6.3	W_x 2.1	SEMIPILASTRINO (PAG. 4.44)
	1.885	J_y 92.4	W_y 12.6	
	175031	J_x 5.6	W_x 1.4	CIELINO MONOBLOCCO (PAG. 4.45)
	1.707	J_y 51.1	W_y 9.1	
	175032	J_x 64.4	W_x 7.7	SPALLA MONOBLOCCO (PAG. 4.46)
	2.406	J_y 147.7	W_y 17.5	
	175035	J_x 23.8	W_x 4.9	PROFILATO CAPANNONI (PAG. 4.50)
	2.187	J_y 74.9	W_y 10.5	
	175039	J_x 9.1	W_x 2.8	ANTA Z RAGGIATA TUBOLARITÀ STANDARD (PAG. 4.12)
	1.508	J_y 37.8	W_y 8.4	
	175040	J_x 10.5	W_x 2.8	TELAIO L SEMI-MAGGIORATO (PAG. 4.10)
	1.441	J_y 30.8	W_y 7.7	
	175041	J_x 7.0	W_x 2.1	TRAVERSO CON CAVALOTTI TUBOLARITÀ STANDARD PER ANTA PIANA (PAG. 4.37)
	1.422	J_y 35.7	W_y 7.7	
	175042	J_x 27.3	W_x 5.6	TRAVERSO CON CAVALOTTI TUBOLARITÀ MAGGIORATA PER ANTA PIANA (PAG. 4.38)
	1.840	J_y 47.6	W_y 10.5	
	175043	J_x 88.9	W_x 14.0	ZOCCOLO RIPORTATO PER ANTA PIANA (PAG. 4.39)
	2.556	J_y 67.2	W_y 15.4	



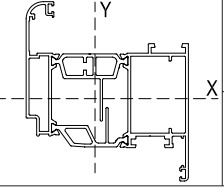
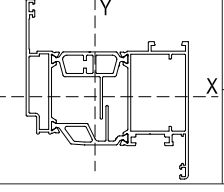
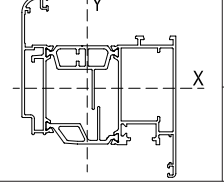
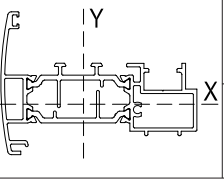
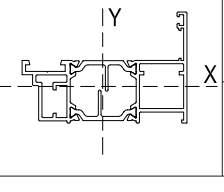
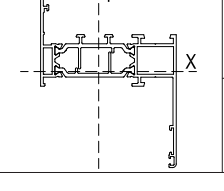
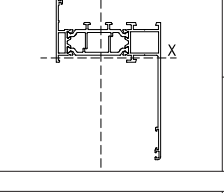
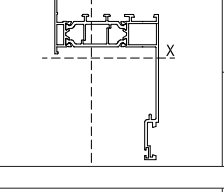
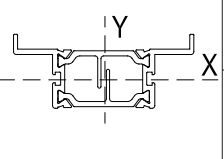

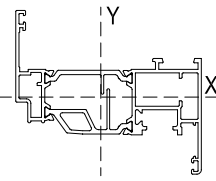
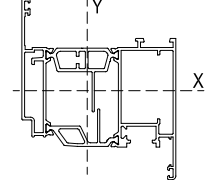
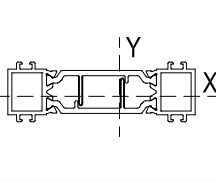
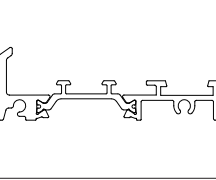
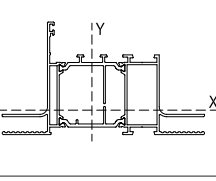
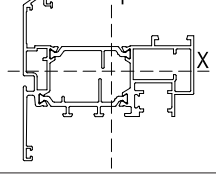
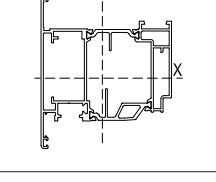
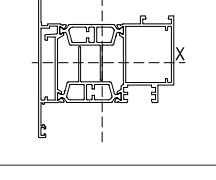
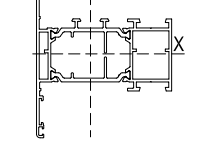
 SAGOMA	ARTICOLO	INERZIA	MODULO	DESCRIZIONE
	PESO (Kg/m)	cm ⁴	cm ³	
	175044	J_x 173.6	W_x 21.7	FASCIA CON CAVALLOTTI PER ANTA PIANA (PAG. 4.40)
	3.065	J_y 83.3	W_y 18.9	
	175045	J_x 177.8	W_x 22.4	ZOCCOLO CON CAVALLOTTI PER ANTA PIANA (PAG. 4.42)
	3.073	J_y 87.5	W_y 27.3	
	175050	J_x 9.1	W_x 2.8	ANTA Z STORICA TUBOLARITÀ STANDARD (PAG. 4.13)
	1.515	J_y 38.5	W_y 8.4	
	175051	J_x 39.9	W_x 7.7	ANTA Z SGUSCIATA PISTA 16 TUBOLARITÀ MAGGIORATA (PAG. 4.17)
	2.233	J_y 55.3	W_y 11.9	
	175052	J_x 7.0	W_x 2.1	TRAVERSO CON VITI TUBOLARITÀ STANDARD PER ANTA PIANA (PAG. 4.37)
	1.591	J_y 39.9	W_y 9.1	
	175053	J_x 28.7	W_x 5.6	TRAVERSO CON VITI TUBOLARITÀ MAGGIORATA PER ANTA PIANA (PAG. 4.38)
	2.010	J_y 51.8	W_y 11.9	
	175054	J_x 181.3	W_x 26.6	FASCIA CON VITI TUBOLARITÀ MAGGIORATA PER ANTA PIANA (PAG. 4.41)
	3.091	J_y 83.3	W_y 18.9	
	175055	J_x 186.9	W_x 23.1	ZOCCOLO CON VITI TUBOLARITÀ MAGGIORATA PER ANTA PIANA (PAG. 4.43)
	3.177	J_y 90.3	W_y 21.0	
	175056	J_x 12.6	W_x 3.5	ANTA Z ARROTONDATA PISTA 16 TUBOLARITÀ STANDARD (PAG. 4.14)
	1.684	J_y 42.0	W_y 9.8	

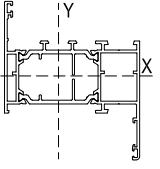
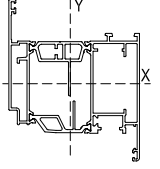
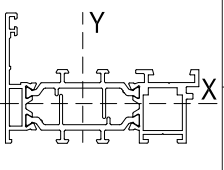
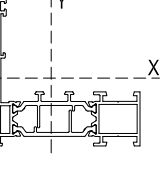
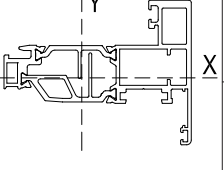
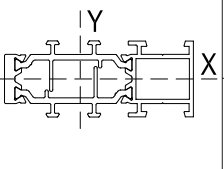
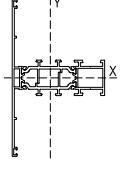
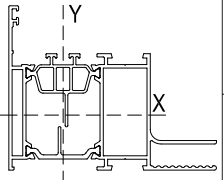
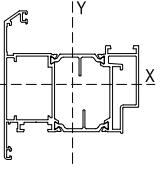

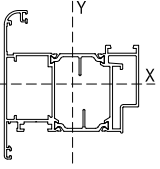
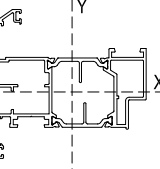
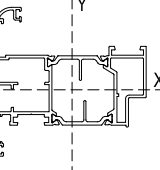
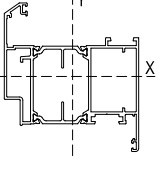
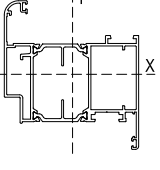
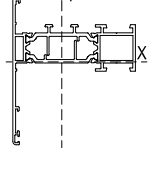
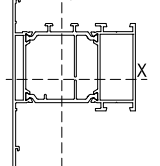
 SAGOMA	ARTICOLO	INERZIA	MODULO	DESCRIZIONE
	PESO (Kg/m)	cm ⁴	cm ³	
	175057	J_x 31.5	W_x 6.3	ANTA Z ARROTONDATA TUBOLARITÀ MAGGIORATA (PAG. 4.16)
	2.016	J_y 50.4	W_y 11.2	
	175058	J_x 28.7	W_x 5.6	ANTA Z PIANA TUBOLARITÀ MAGGIORATA (PAG. 4.16)
	1.963	J_y 49.7	W_y 11.2	
	175059	J_x 39.9	W_x 7.7	ANTA Z ARROTONDATA PISTA 16 TUBOLARITÀ MAGGIORATA (PAG. 4.17)
	2.237	J_y 55.3	W_y 12.6	
	175065	J_x 7.0	W_x 2.1	RIPORTO ARROTONDATO CENTRALE PISTA 16 (PAG. 4.26)
	1.448	J_y 33.6	W_y 7.0	
	175066	J_x 4.6	W_x 1.4	RIPORTO APERTURA ESTERNA INSERIMENTO IN VETRINA (PAG. 4.27)
	1289	J_y 21.0	W_y 4.9	
	175067	J_x 14.0	W_x 2.8	TELAIO L TUBOLARITÀ STANDARD ALETTA DA 45 mm (PAG. 4.4)
	1.453	J_y 33.6	W_y 9.1	
	175068	J_x 29.4	W_x 3.5	TELAIO L TUBOLARITÀ STANDARD ALETTA DA 70 mm (PAG. 4.5)
	1.589	J_y 37.8	W_y 9.1	
	175078	J_x 47.6	W_x 6.3	SPALLA MONOBLOCCO (PAG. 4.47)
	1.686	J_y 39.9	W_y 9.8	
	175080	J_x	W_x	PROFILATO COMPLEMENTARE PER INSERIMENTO IN FACCIATA (PAG. 4.54)
	0.796	J_y	W_y	

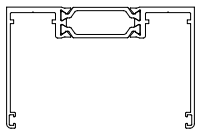
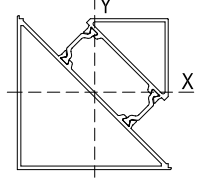
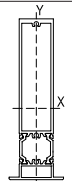
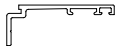
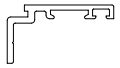
 SAGOMA	ARTICOLO	INERZIA	MODULO	DESCRIZIONE
	PESO (Kg/m)	cm ⁴	cm ³	
	175081	<i>J_x</i> 10.5	<i>W_x</i> 2.8	ANTA Z PIANA PISTA 16 TUBOLARITÀ STANDARD (PAG. 4.15)
	1.631	<i>J_y</i> 40.6	<i>W_y</i> 9.8	
	175084	<i>J_x</i> 37.1	<i>W_x</i> 7.0	ANTA Z PINA PISTA 16 TUBOLARITÀ MAGGIORATA (PAG. 4.18)
	2.183	<i>J_y</i> 54.6	<i>W_y</i> 11.9	
	175086	<i>J_x</i> 1.4	<i>W_x</i> 1.4	PROFILATO PER GIUNZIONE TELAI A L (PAG. 4.54)
	0.998	<i>J_y</i> 18.9	<i>W_y</i> 4.9	
	175087	<i>J_x</i>	<i>W_x</i>	SOGLIA RIBASSATA (PAG. 4.5)
	0.815	<i>J_y</i>	<i>W_y</i>	
	175092	<i>J_x</i> 28.0	<i>W_x</i> 5.6	PROFILATO CAPANNONI (PAG. 4.51)
	2.173	<i>J_y</i> 74.9	<i>W_y</i> 10.5	
	175095	<i>J_x</i> 16.8	<i>W_x</i> 4.2	ANTA A T SGUSCIATA P16 TUBOLARITÀ STANDARD (PAG. 4.24)
	1.878	<i>J_y</i> 44.8	<i>W_y</i> 9.1	
	175113	<i>J_x</i> 43.4	<i>W_x</i> 7.7	ANTA APERTURA ESTERNA MAGGIORATA LINE PIANA P. 16 DOPPIA BATTUTA (PAG. 4.22)
	2244	<i>J_y</i> 51.1	<i>W_y</i> 12.6	
	175114	<i>J_x</i> 32.2	<i>W_x</i> 6.3	ANTA PIANA APERTURA BILICO (PAG. 4.18)
	2165	<i>J_y</i> 51.1	<i>W_y</i> 9.8	
	175115	<i>J_x</i> 15.4	<i>W_x</i> 3.5	TELAIO SEMI-MAGGIORATO FISSO A T (PAG. 4.15)
	1579	<i>J_y</i> 34.3	<i>W_y</i> 7.7	

 SAGOMA	ARTICOLO	INERZIA	MODULO	DESCRIZIONE
	PESO (Kg/m)	cm ⁴	cm ³	
	175116	J_x 14.7	W_x 3.5	TELAIO SEMI-MAGGIORATO FISSO A Z (PAG. 4.16)
	15669	J_y 35.7	W_y 9.1	
	175117	J_x 44.8	W_x 8.4	ANTA MAGGIORATA PIANA P.16 (PAG. 4.22)
	2378	J_y 57.4	W_y 12.6	
	175119	J_x 4.9	W_x 1.4	RIPORTO (PAG. 4.28)
	1268	J_y 25.2	W_y 6.3	
	175120	J_x 13.3	W_x 2.1	TELAIO L ANTA A SCOMPARSA (PAG. 4.10)
	1379	J_y 29.4	W_y 6.3	
	175121	J_x 8.4	W_x 2.8	ANTA A SCOMPARSA (PAG. 4.23)
	1611	J_y 34.3	W_y 7.7	
	175122	J_x 4.9	W_x 2.1	RIPORTO PER FISSA LATERALE ANTA A SCOMPARSA (PAG. 4.27)
	1089	J_y 20.3	W_y 2.8	
	175123	J_x 25.2	W_x 4.2	TRAVERSO / MONTANTE PER ANTA A SCOMPARSA (PAG. 4.31)
	1615	J_y 33.6	W_y 7	
	665124	J_x 29.4	W_x 5.6	TELAIO L CAPANNONI (PAG. 4.49)
	1904	J_y 44.8	W_y 7	
	175126	J_x 31.5	W_x 6.3	ANTA APERTURA ESTERNA MAGGIORATA DOPPIA BATTUTA LINEA SGUSCIATA (PAG. 4.19)
	2108	J_y 49.7	W_y 11.5	

 SAGOMA	ARTICOLO	INERZIA	MODULO	DESCRIZIONE
	PESO (Kg/m)	cm ⁴	cm ³	
	175127	<i>J_x</i> 31.5	<i>W_x</i> 6.3	ANTA APERTURA ESTERNA MAGGIORATA DOPPIA BATTUTA LINEA AROTONDATA (PAG. 4.19)
	2111	<i>J_y</i> 49.7	<i>W_y</i> 11.2	
	175128	<i>J_x</i> 20.3	<i>W_x</i> 4.9	ANTA APERTURA ESTERNA STANDARD DOPPIA BATTUTA LINEA SGUSCIATA (PAG. 4.20)
	1920	<i>J_y</i> 44.8	<i>W_y</i> 9.8	
	175129	<i>J_x</i> 20.3	<i>W_x</i> 4.9	ANTA APERTURA ESTERNA STANDARD DOPPIA BATTUTA LINEA AROTONDATA (PAG. 4.20)
	1924	<i>J_y</i> 44.8	<i>W_y</i> 9.8	
	175130	<i>J_x</i> 31.5	<i>W_x</i> 6.3	ANTA APERTURA INTERNA MAGGIORATA DOPPIA BATTUTA LINEA SGUSCIATA (PAG. 4.21)
	2068	<i>J_y</i> 49	<i>W_y</i> 11.2	
	175131	<i>J_x</i> 31.5	<i>W_x</i> 6.3	ANTA APERTURA INTERNA MAGGIORATA DOPPIA BATTUTA LINEA AROTONDATA (PAG. 4.21)
	2160	<i>J_y</i> 49	<i>W_y</i> 11.2	
	175132	<i>J_x</i> 14.7	<i>W_x</i> 2.8	TELAIO STANDARD FISSO T ALETTA LUNGA DA 45MM (PAG. 4.6)
	1465	<i>J_y</i> 30.8	<i>W_y</i> 7	
	175133	<i>J_x</i> 37.8	<i>W_x</i> 5.6	TELAIO MAGGIORATO FISSO T ALETTA LUNGA DA 45MM (PAG. 4.9)
	1882	<i>J_y</i> 41.3	<i>W_y</i> 9.1	

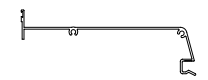
 SAGOMA	ARTICOLO	INERZIA	MODULO	DESCRIZIONE
	PESO (Kg/m)	cm ⁴	cm ³	
	82059	<i>J_x</i>	<i>W_x</i>	PROFILATO COMPENSATORE (PAG. 4.4)
	1.338	<i>J_y</i>	<i>W_y</i>	
	61727	<i>J_x</i> 38.9	<i>W_x</i> 9.7	PROFILATO AD ANGOLO 90° (PAG. 4.45)
	2.129	<i>J_y</i> 38.9	<i>W_y</i> 9.7	
	55590	<i>J_x</i> 11.8	<i>W_x</i> 3.4	MONTANTE UNIVERSALE (PAG. 4.53)
	2.089	<i>J_y</i> 4.6	<i>W_y</i> 1.4	
	665276	<i>J_x</i>	<i>W_x</i>	COPRIFILO A MURO 40 mm (PAG. 4.55)
	0.306	<i>J_y</i>	<i>W_y</i>	
	665277	<i>J_x</i>	<i>W_x</i>	COPRIFILO A MURO 26 mm (PAG. 4.55)
	0.244	<i>J_y</i>	<i>W_y</i>	
	665278	<i>J_x</i>	<i>W_x</i>	COPRIFILO A MURO 70 mm (PAG. 4.55)
	0.475	<i>J_y</i>	<i>W_y</i>	
	665438	<i>J_x</i> -	<i>W_x</i> -	FERMAVETRO ANTA A SCOMPARSA (PAG. 4.23)
	161	<i>J_y</i> -	<i>W_y</i> -	
	72524	<i>J_x</i>	<i>W_x</i>	MANINA SUPPORTO VETRO PER ANTA A SCOMPARSA ART. 665047 (PAG. 4.49)
	0.257	<i>J_y</i>	<i>W_y</i>	
	1234	<i>J_x</i>	<i>W_x</i>	COPRICAVA MONOBLOCCO (PAG. 4.46)
	0.151	<i>J_y</i>	<i>W_y</i>	

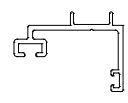
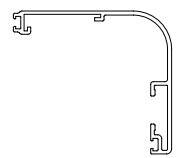
 SAGOMA	ARTICOLO	INERZIA	MODULO	DESCRIZIONE
	PESO (Kg/m)	cm ⁴	cm ³	
	1184	<i>J_x</i>	<i>W_x</i>	PROFILATO PER CASSONETTO MONOBLOCCO (PAG. 4.48)
	1.165	<i>J_y</i>	<i>W_y</i>	
	1185	<i>J_x</i>	<i>W_x</i>	PROFILATO PER CASSONETTO MONOBLOCCO (PAG. 4.48)
	1.250	<i>J_y</i>	<i>W_y</i>	
	6405	<i>J_x</i>	<i>W_x</i>	ASTINA DI COLLEGAMENTO (PAG. 4.57)
	0.159	<i>J_y</i>	<i>W_y</i>	
	40269	<i>J_x</i>	<i>W_x</i>	PROFILATO GOCCIOLATOIO (PAG. 4.56)
	0.141	<i>J_y</i>	<i>W_y</i>	
	40272	<i>J_x</i>	<i>W_x</i>	PROFILATO MONTANTE PER INGLESINA (PAG. 4.56)
	0.184	<i>J_y</i>	<i>W_y</i>	
	40273	<i>J_x</i>	<i>W_x</i>	PROFILATO TRAVERSO PER INGLESINA (PAG. 4.56)
	0.178	<i>J_y</i>	<i>W_y</i>	
	40282	<i>J_x</i>	<i>W_x</i>	PROFILATO SOTTOPORTA (PAG. 4.57)
	0.375	<i>J_y</i>	<i>W_y</i>	
	40291	<i>J_x</i>	<i>W_x</i>	IMBOTTE DA 62 mm (PAG. 4.52)
	0.641	<i>J_y</i>	<i>W_y</i>	
	40292	<i>J_x</i>	<i>W_x</i>	IMBOTTE DA 92 mm (PAG. 4.52)
	0.770	<i>J_y</i>	<i>W_y</i>	

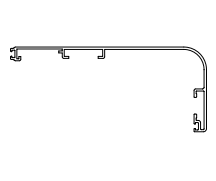
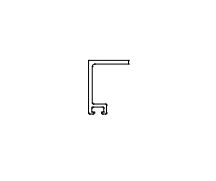
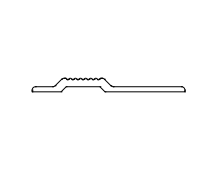
 SAGOMA	ARTICOLO	INERZIA	MODULO	DESCRIZIONE
	<i>PESO (Kg/m)</i>	<i>cm⁴</i>	<i>cm³</i>	
	40293	<i>J_x</i>	<i>W_x</i>	IMBOTTE DA 129.5 mm (PAG. 4.52)
	0.985	<i>J_y</i>	<i>W_y</i>	
	50052	<i>J_x</i>	<i>W_x</i>	PROFILATO PORTA SPAZZOLINO (PAG. 4.56)
	0.175	<i>J_y</i>	<i>W_y</i>	
	72531	<i>J_x</i>	<i>W_x</i>	SOGLIA PIATTA (PAG. 4.57)
	0.226	<i>J_y</i>	<i>W_y</i>	

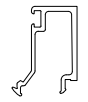
 SAGOMA	ARTICOLO	INERZIA	MODULO	DESCRIZIONE
	PESO (Kg/m)	cm ⁴	cm ³	
	40007	<i>J_x</i>	<i>W_x</i>	FERMAVETRO PIANO DA 25,5 MM (PAG. 4.59)
	0.318	<i>J_y</i>	<i>W_y</i>	
	40029	<i>J_x</i>	<i>W_x</i>	FERMAVETRO PIANO DA 20,5 MM (PAG. 4.59)
	0.283	<i>J_y</i>	<i>W_y</i>	
	40030	<i>J_x</i>	<i>W_x</i>	FERMAVETRO PIANO DA 13,5 MM (PAG. 4.59)
	0.263	<i>J_y</i>	<i>W_y</i>	
	40037	<i>J_x</i>	<i>W_x</i>	FERMAVETRO PIANO DA 35,5 MM (PAG. 4.60)
	0.359	<i>J_y</i>	<i>W_y</i>	
	40039	<i>J_x</i>	<i>W_x</i>	FERMAVETRO PIANO DA 30,5 MM (PAG. 4.60)
	0.339	<i>J_y</i>	<i>W_y</i>	
	40077	<i>J_x</i>	<i>W_x</i>	FERMAVETRO ARROTONDATO DA 35,5 MM (PAG. 4.65)
	0.352	<i>J_y</i>	<i>W_y</i>	
	40078	<i>J_x</i>	<i>W_x</i>	FERMAVETRO ARROTONDATO DA 33 MM (PAG. 4.64)
	0.342	<i>J_y</i>	<i>W_y</i>	
	40079	<i>J_x</i>	<i>W_x</i>	FERMAVETRO ARROTONDATO DA 30,5 MM (PAG. 4.64)
	0.332	<i>J_y</i>	<i>W_y</i>	
	40080	<i>J_x</i>	<i>W_x</i>	FERMAVETRO ARROTONDATO DA 25,5 MM (PAG. 4.64)
	0.312	<i>J_y</i>	<i>W_y</i>	

 SAGOMA	ARTICOLO	INERZIA	MODULO	DESCRIZIONE
	PESO (Kg/m)	cm ⁴	cm ³	
	40081	<i>J_x</i>	<i>W_x</i>	FERMAVETRO ARROTONDATO DA 23,5 MM (PAG. 4.64)
	0.293	<i>J_y</i>	<i>W_y</i>	
	40082	<i>J_x</i>	<i>W_x</i>	FERMAVETRO ARROTONDATO DA 20,5 MM (PAG. 4.64)
	0.274	<i>J_y</i>	<i>W_y</i>	
	40083	<i>J_x</i>	<i>W_x</i>	FERMAVETRO ARROTONDATO DA 13,5 MM (PAG. 4.64)
	0.252	<i>J_y</i>	<i>W_y</i>	
	40085	<i>J_x</i>	<i>W_x</i>	FERMAVETRO PIANO DA 5,5 MM (PAG. 4.59)
	0.210	<i>J_y</i>	<i>W_y</i>	
	40086	<i>J_x</i>	<i>W_x</i>	FERMAPANNELLO DA 2 MM (PAG. 4.59)
	0.178	<i>J_y</i>	<i>W_y</i>	
	40087	<i>J_x</i>	<i>W_x</i>	FERMAVETRO PIANO DA 23,5 MM (PAG. 4.59)
	0.303	<i>J_y</i>	<i>W_y</i>	
	40089	<i>J_x</i>	<i>W_x</i>	FERMAVETRO CON CLIP DA 35,5 MM (PAG. 4.62)
	0.348	<i>J_y</i>	<i>W_y</i>	
	40090	<i>J_x</i>	<i>W_x</i>	FERMAVETRO CON CLIP DA 33 MM (PAG. 4.62)
	0.336	<i>J_y</i>	<i>W_y</i>	
	40091	<i>J_x</i>	<i>W_x</i>	FERMAVETRO CON CLIP DA 30,5 MM (PAG. 4.62)
	0.324	<i>J_y</i>	<i>W_y</i>	

 SAGOMA	ARTICOLO	INERZIA	MODULO	DESCRIZIONE
	PESO (Kg/m)	cm ⁴	cm ³	
	40092	<i>Jx</i>	<i>Wx</i>	FERMAVETRO CON CLIP DA 25,5 MM (PAG. 4.61)
	0.291	<i>Jy</i>	<i>Wy</i>	
	40093	<i>Jx</i>	<i>Wx</i>	FERMAVETRO CON CLIP DA 23,5 MM (PAG. 4.61)
	0.282	<i>Jy</i>	<i>Wy</i>	
	40094	<i>Jx</i>	<i>Wx</i>	FERMAVETRO CON CLIP DA 20,5 MM (PAG. 4.61)
	0.268	<i>Jy</i>	<i>Wy</i>	
	40095	<i>Jx</i>	<i>Wx</i>	FERMAVETRO CON CLIP DA 13,5 MM (PAG. 4.61)
	0.236	<i>Jy</i>	<i>Wy</i>	
	40096	<i>Jx</i>	<i>Wx</i>	FERMAVETRO CON CLIP DA 10,5 MM (PAG. 4.61)
	0.221	<i>Jy</i>	<i>Wy</i>	
	40097	<i>Jx</i>	<i>Wx</i>	FERMAVETRO CON CLIP DA 5,5 MM (PAG. 4.61)
	0.199	<i>Jy</i>	<i>Wy</i>	
	40098	<i>Jx</i>	<i>Wx</i>	FERMAPANNELLO CON CLIP DA 2 MM (PAG. 4.61)
	0.169	<i>Jy</i>	<i>Wy</i>	
	40111	<i>Jx</i>	<i>Wx</i>	FERMAVETRO PIANO DA 33 MM (PAG. 4.60)
	0.347	<i>Jy</i>	<i>Wy</i>	
	40185	<i>Jx</i>	<i>Wx</i>	FERMAVETRO PIANO DA 17,5 MM (PAG. 4.59)
	0.280	<i>Jy</i>	<i>Wy</i>	

 SAGOMA	ARTICOLO	INERZIA	MODULO	DESCRIZIONE
	PESO (Kg/m)	cm ⁴	cm ³	
	40186	<i>J_x</i>	<i>W_x</i>	FERMAVETRO ARROTONDATO DA 17,5 MM (PAG. 4.64)
	0.272	<i>J_y</i>	<i>W_y</i>	
	40187	<i>J_x</i>	<i>W_x</i>	FERMAVETRO CON CLIP DA 17,5 MM (PAG. 4.61)
	0.254	<i>J_y</i>	<i>W_y</i>	
	40216	<i>J_x</i>	<i>W_x</i>	FERMAVETRO ARROTONDATO DA 15 MM (PAG. 4.64)
	0.259	<i>J_y</i>	<i>W_y</i>	
	40217	<i>J_x</i>	<i>W_x</i>	FERMAVETRO PIANO DA 15 MM (PAG. 4.59)
	0.267	<i>J_y</i>	<i>W_y</i>	
	40218	<i>J_x</i>	<i>W_x</i>	FERMAVETRO CON CLIP DA 15 MM (PAG. 4.61)
	0.243	<i>J_y</i>	<i>W_y</i>	
	40225	<i>J_x</i>	<i>W_x</i>	FERMAVETRO ARROTONDATO CON SCURETTO DA 13,5 MM (PAG. 4.65)
	0.261	<i>J_y</i>	<i>W_y</i>	
	40226	<i>J_x</i>	<i>W_x</i>	FERMAVETRO ARROTONDATO CON SCURETTO DA 20,5 MM (PAG. 4.65)
	0.270	<i>J_y</i>	<i>W_y</i>	
	40227	<i>J_x</i>	<i>W_x</i>	FERMAVETRO ARROTONDATO CON SCURETTO DA 30,5 MM (PAG. 4.65)
	0.341	<i>J_y</i>	<i>W_y</i>	
	40228	<i>J_x</i>	<i>W_x</i>	FERMAVETRO ARROTONDATO CON SCURETTO DA 17,5 MM (PAG. 4.65)
	0.278	<i>J_y</i>	<i>W_y</i>	

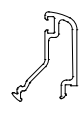
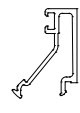
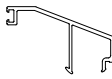
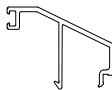
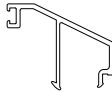
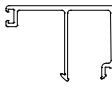
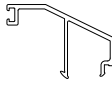
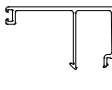
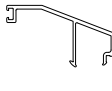
 SAGOMA	ARTICOLO	INERZIA	MODULO	DESCRIZIONE
	PESO (Kg/m)	cm ⁴	cm ³	
	40247	<i>J_x</i>	<i>W_x</i>	FERMAVETRO ARROTONDATO DA 9,5 MM (PAG. 4.64)
	0.229	<i>J_y</i>	<i>W_y</i>	
	40249	<i>J_x</i>	<i>W_x</i>	FERMAVETRO PIANO DA 9,5 MM (PAG. 4.59)
	0.242	<i>J_y</i>	<i>W_y</i>	
	40261	<i>J_x</i>	<i>W_x</i>	FERMAVETRO DESIGN DA 42.5 MM (PAG. 4.66)
	0.327	<i>J_y</i>	<i>W_y</i>	
	40262	<i>J_x</i>	<i>W_x</i>	FERMAVETRO DESIGN DA 34.5 MM (PAG. 4.66)
	0.302	<i>J_y</i>	<i>W_y</i>	
	40274	<i>J_x</i>	<i>W_x</i>	FERMAVETRO DESIGN DA 33 MM (PAG. 4.66)
	0.298	<i>J_y</i>	<i>W_y</i>	
	40275	<i>J_x</i>	<i>W_x</i>	FERMAVETRO PIANO DA 38.5 MM (PAG. 4.60)
	0.379	<i>J_y</i>	<i>W_y</i>	
	40276	<i>J_x</i>	<i>W_x</i>	FERMAVETRO DESIGN DA 38.5 MM (PAG. 4.66)
	0.330	<i>J_y</i>	<i>W_y</i>	
	40277	<i>J_x</i>	<i>W_x</i>	FERMAVETRO PIANO DA 46.5 MM (PAG. 4.60)
	0.414	<i>J_y</i>	<i>W_y</i>	
	40278	<i>J_x</i>	<i>W_x</i>	FERMAVETRO DESIGN DA 46.5 MM (PAG. 4.66)
	0.357	<i>J_y</i>	<i>W_y</i>	

 SAGOMA	ARTICOLO	INERZIA	MODULO	DESCRIZIONE
	PESO (Kg/m)	cm ⁴	cm ³	
	40316	<i>J_x</i>	<i>W_x</i>	FERMAVETRO DESIGN DA 25.5 MM (PAG. 4.66)
	0.283	<i>J_y</i>	<i>W_y</i>	
	40326	<i>J_x</i>	<i>W_x</i>	FERMAVETRO PIANO DA 28 MM (PAG. 4.60)
	0.329	<i>J_y</i>	<i>W_y</i>	
	40327	<i>J_x</i>	<i>W_x</i>	FERMAVETRO TUBOLARE DA 13.5 MM (PAG. 4.63)
	0.311	<i>J_y</i>	<i>W_y</i>	
	40328	<i>J_x</i>	<i>W_x</i>	FERMAVETRO TUBOLARE DA 23.5 MM (PAG. 4.63)
	0.425	<i>J_y</i>	<i>W_y</i>	
	40329	<i>J_x</i>	<i>W_x</i>	FERMAVETRO TUBOLARE DA 28 MM (PAG. 4.63)
	0.405	<i>J_y</i>	<i>W_y</i>	
	41258	<i>J_x</i>	<i>W_x</i>	FERMAVETRO TUBOLARE DA 17.5 MM (PAG. 4.63)
	0.342	<i>J_y</i>	<i>W_y</i>	
	41259	<i>J_x</i>	<i>W_x</i>	FERMAVETRO TUBOLARE DA 20.5 MM (PAG. 4.63)
	0.359	<i>J_y</i>	<i>W_y</i>	
	72501	<i>J_x</i>	<i>W_x</i>	FERMAVETRO DESIGN DA 25.5 MM CON CLIP (PAG. 4.67)
	0.331	<i>J_y</i>	<i>W_y</i>	
	72502	<i>J_x</i>	<i>W_x</i>	FERMAVETRO DESIGN DA 31 MM CON CLIP (PAG. 4.67)
	0.364	<i>J_y</i>	<i>W_y</i>	

 SAGOMA	ARTICOLO	INERZIA	MODULO	DESCRIZIONE
	PESO (Kg/m)	cm ⁴	cm ³	
	72503	<i>J_x</i>	<i>W_x</i>	FERMAVETRO DESIGN DA 41 MM CON CLIP (PAG. 4.67)
	0.428	<i>J_y</i>	<i>W_y</i>	
	72504	<i>J_x</i>	<i>W_x</i>	FERMAVETRO DESIGN DA 47.5 MM CON CLIP (PAG. 4.67)
	0.492	<i>J_y</i>	<i>W_y</i>	
	72505	<i>J_x</i>	<i>W_x</i>	FERMAVETRO PIANO DA 41 MM (PAG. 4.60)
	0.392	<i>J_y</i>	<i>W_y</i>	
	72506	<i>J_x</i>	<i>W_x</i>	FERMAVETRO PIANO DA 47.5 MM (PAG. 4.60)
	0.420	<i>J_y</i>	<i>W_y</i>	
	72507	<i>J_x</i>	<i>W_x</i>	FERMAVETRO ARROTONDATO DA 41 MM (PAG. 4.65)
	0.380	<i>J_y</i>	<i>W_y</i>	
	72508	<i>J_x</i>	<i>W_x</i>	FERMAVETRO ARROTONDATO DA 45.5 MM (PAG. 4.65)
	0.416	<i>J_y</i>	<i>W_y</i>	
	72509	<i>J_x</i>	<i>W_x</i>	FERMAVETRO DESIGN DA 34 MM CON CLIP (PAG. 4.67)
	0.382	<i>J_y</i>	<i>W_y</i>	
	72512	<i>J_x</i>	<i>W_x</i>	FERMAVETRO DESIGN DA 28 MM CON CLIP (PAG. 4.67)
	0.348	<i>J_y</i>	<i>W_y</i>	
	72519	<i>J_x</i>	<i>W_x</i>	FERMAVETRO DESIGN DA 20 MM CON CLIP (PAG. 4.67)
	0.303	<i>J_y</i>	<i>W_y</i>	

 SAGOMA	ARTICOLO	INERZIA	MODULO	DESCRIZIONE
	<i>PESO (Kg/m)</i>	<i>cm⁴</i>	<i>cm³</i>	
	72527	<i>J_x</i>	<i>W_x</i>	FERMAVETRO TUBOLARE DA 35.5 MM (PAG. 4.63)
	0.435	<i>J_y</i>	<i>W_y</i>	
	72528	<i>J_x</i>	<i>W_x</i>	FERMAVETRO TUBOLARE DA 33 MM (PAG. 4.63)
	0.425	<i>J_y</i>	<i>W_y</i>	
	72529	<i>J_x</i>	<i>W_x</i>	FERMAVETRO TUBOLARE DA 30.5 MM (PAG. 4.63)
	0.415	<i>J_y</i>	<i>W_y</i>	
	72530	<i>J_x</i>	<i>W_x</i>	FERMAVETRO TUBOLARE DA 25.5 MM (PAG. 4.63)
	0.395	<i>J_y</i>	<i>W_y</i>	



Profilati Scala 1:1 

TELAIO A MURO

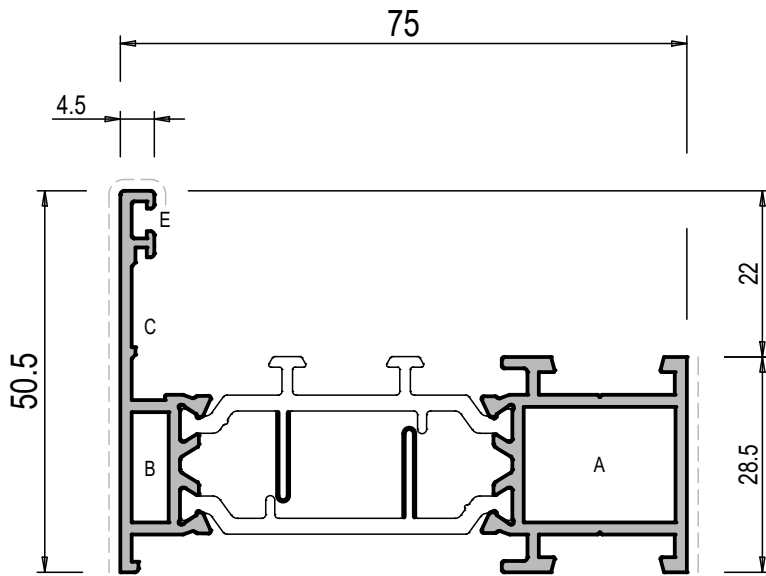

175001

TELAIO FISSO "L"			Jx	4.9
PESO	1231		Jy	25.2
S. VISTA	83.5		Wx	1.4
g/m			Wy	6.3

A	TS078	TS077	GA101	TI001
B	TS079		GA036	TI003
C	G501N			
E	G112			

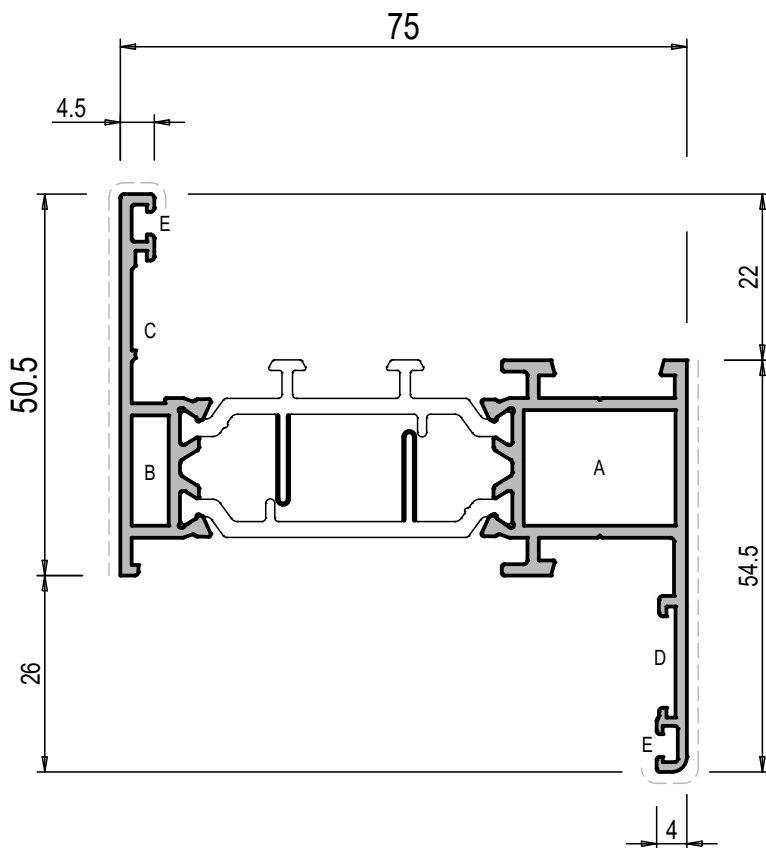

175000

TELAIO FISSO "Z"			Jx	7.7
PESO	1358		Jy	30.8
S. VISTA	113.5		Wx	2.1
g/m			Wy	7.7

A	TS078	TS077	GA101	TI001
B	TS079		GA036	TI003
C	G501N			
E	G112			

TELAIO A MURO

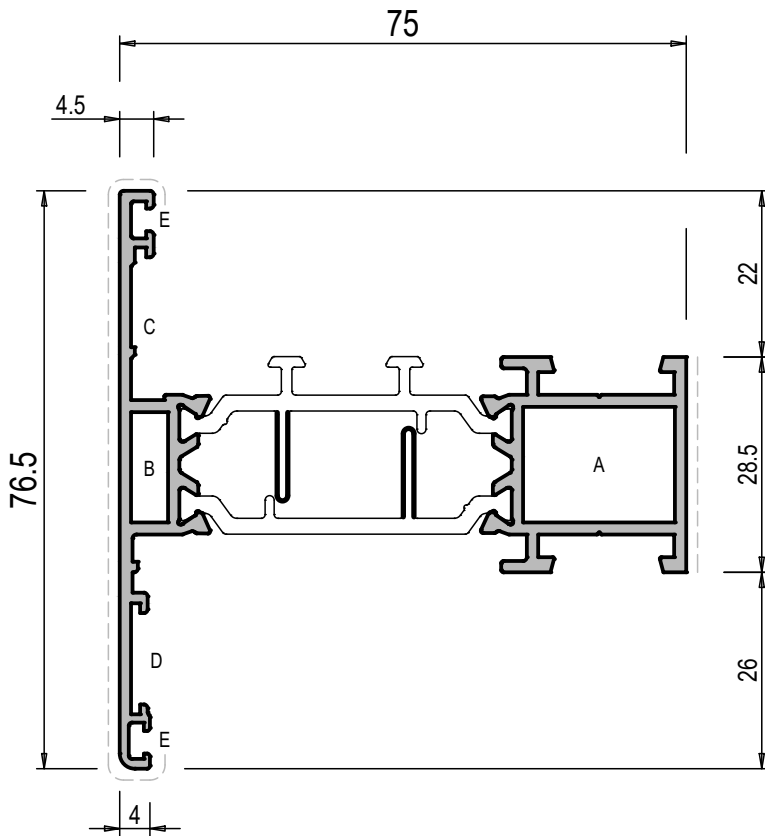

175004

TELAIO FISSO "T"				Jx	7.7
PESO	1367			Jy	28.7
S. VISTA	116			Wx	2.1
				Wy	6.3
A	TS078	TS077	GA101	TI001	
B	TS079			TI003	
C	G501N				
E	G112				

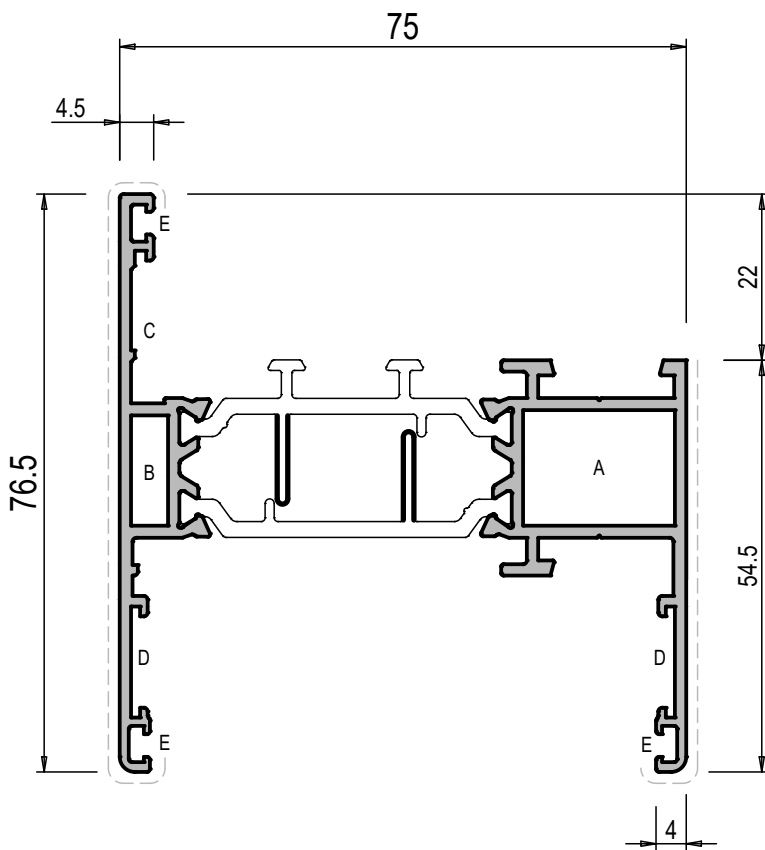

175005

TELAIO FISSO "H"				Jx	10.5
PESO	1494			Jy	34.3
S. VISTA	147			Wx	2.8
				Wy	8.4
A	TS078	TS077	GA101	TI001	
B	TS079			TI003	
C	G501N				
E	G112				

Profilati Scala 1:1



TELAIO A MURO

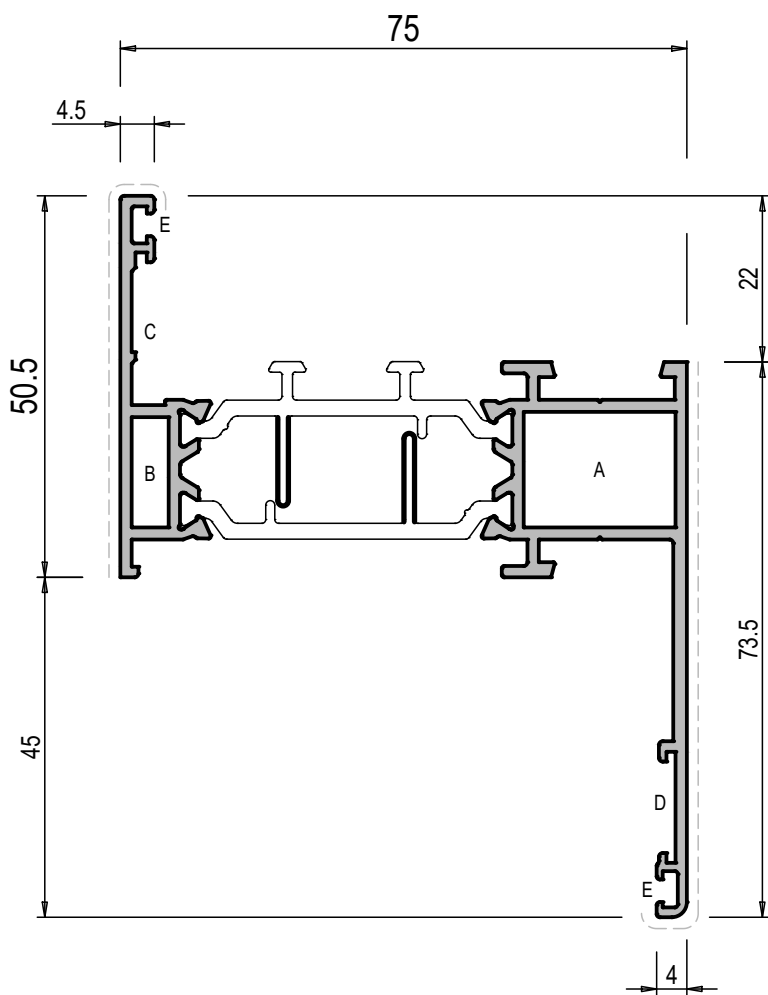

175067

TELAIO FISSO "L" ALETTA DA 45		Jx	cm ⁴	14.0	
PESO	g/m	1453	Jy	cm ⁴	33.6
S. VISTA	mm	132.5	Wx	cm ³	2.8
			Wy	cm ³	9.1

A		TS078		TS077	GA101	TI001
B		TS079			GA036	TI003
C		G501N				
D		G269				
E		G112				

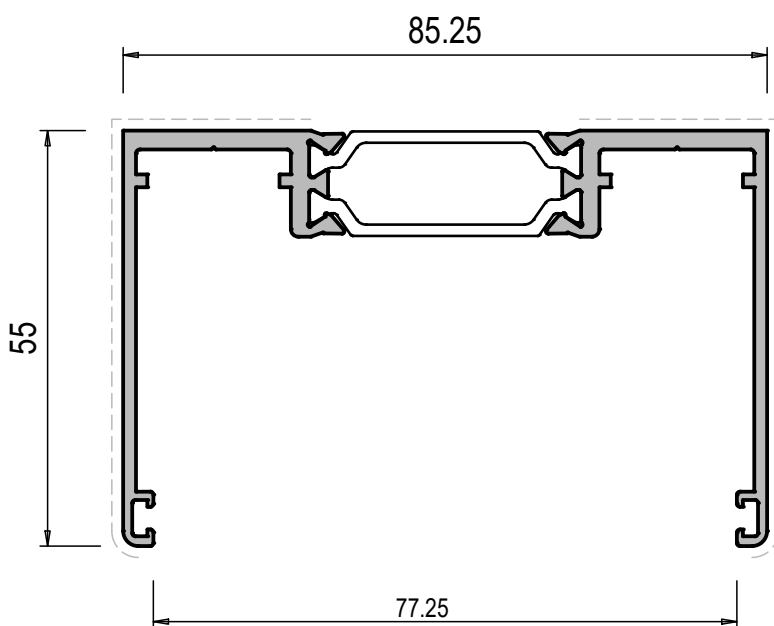

82059

COMPENSATORE		Jx	cm ⁴		
PESO	g/m	1338	Jy	cm ⁴	
S. VISTA	mm	170	Wx	cm ³	
			Wy	cm ³	

TELAIO A MURO

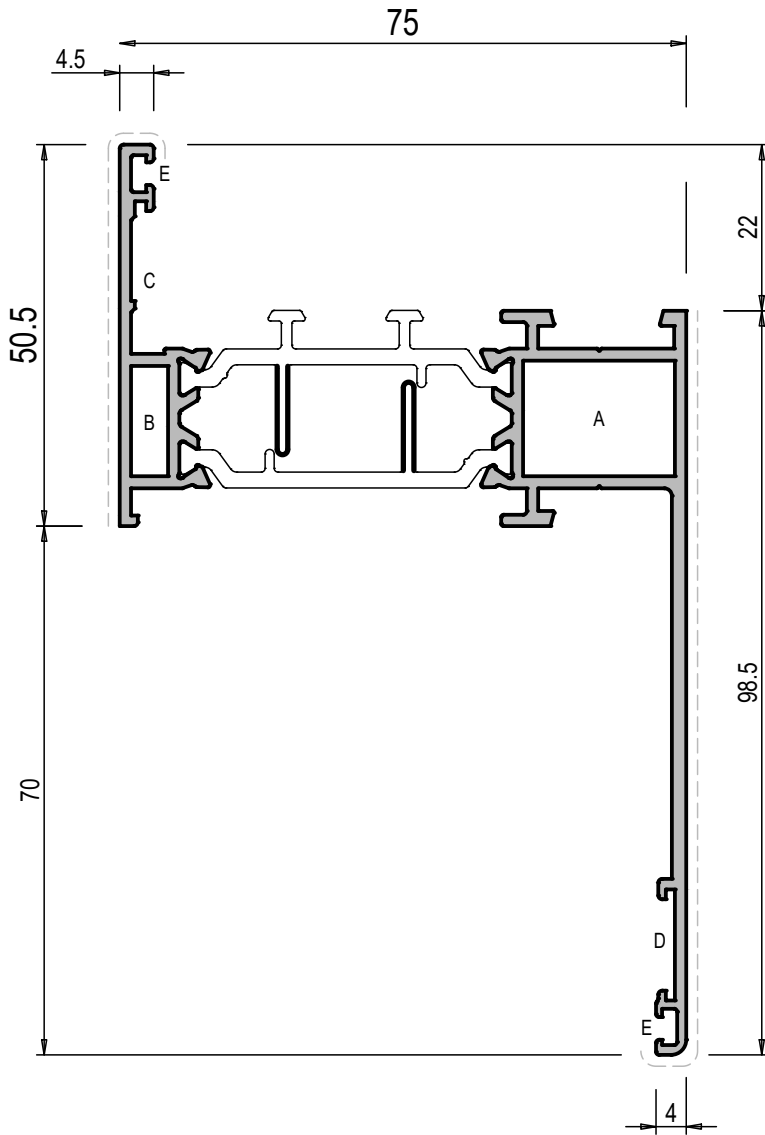

175068

TELAIO FISSO "L" ALETTA DA 70		Jx cm ⁴	29.4
PESO g/m	1589	Jy cm ⁴	37.8
S. VISTA mm	157.5	Wx cm ³	3.5
		Wy cm ³	9.1

A	TS078	TS077	GA101	TI001
B	TS079		GA036	TI003
C	G501N			
D	G269			
E	G112			

SOGLIA RIBASSATA

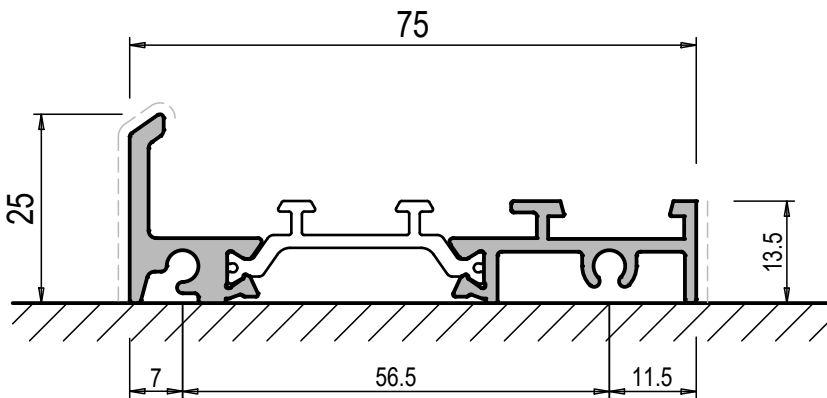

175087

SOGLIA RIBASSATA		Jx cm ⁴	
PESO g/m	815	Jy cm ⁴	
S. VISTA mm	40	Wx cm ³	
		Wy cm ³	

Profilati Scala 1:1



TELAIO A MURO

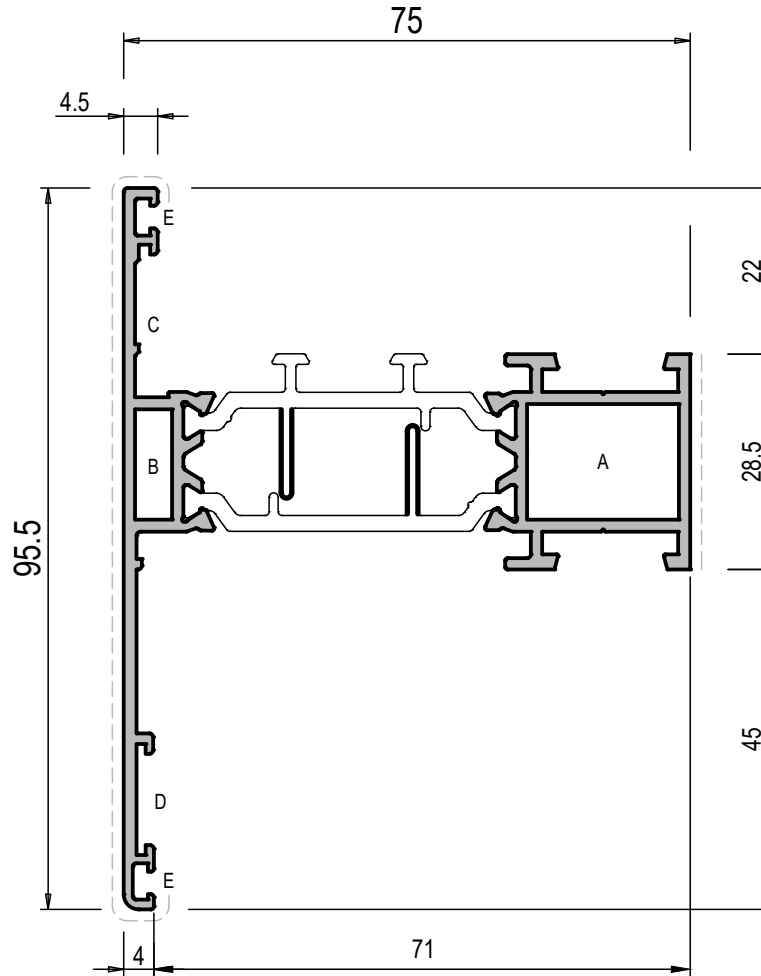

175132

TELAIO FISSO "T" ALETTA 45			Jx	14.7	
PESO	1465		Jy	30.8	
S. VISTA	170		Wx	2.8	
g/m			Wy	7	
mm					
C	G501N				
D	G269				
E	G112				
F	TS080		GA101		Ti001
G	TS081				Ti003

TELAIO A MURO

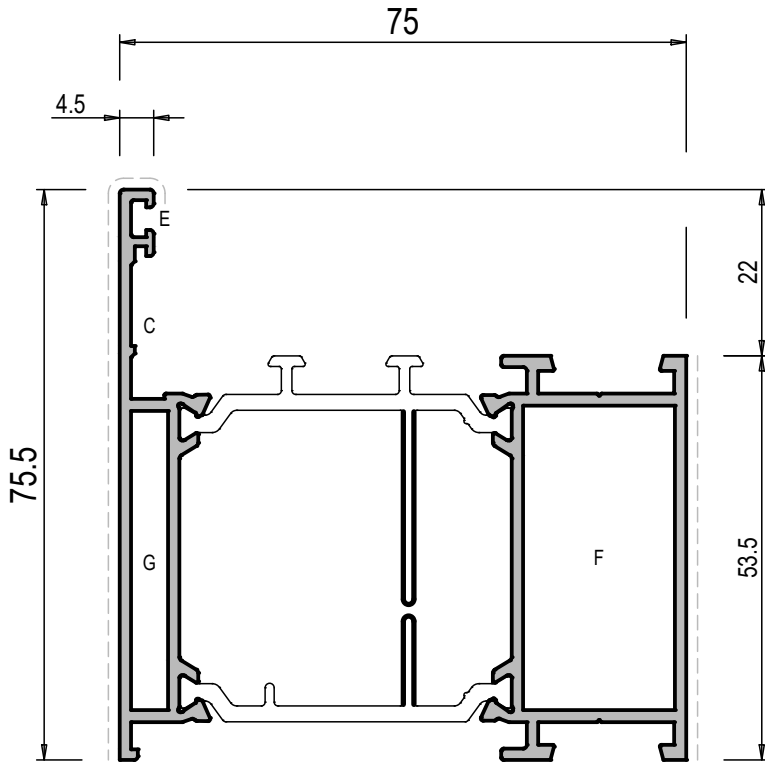

175006

TELAIO MAGGIORATO FISSO "L"		Jx cm ⁴	21.7
PESO g/m	1649	Jy cm ⁴	35.0
S. VISTA mm	134	Wx cm ³	4.9
		Wy cm ³	8.4

C		G501N					
E		G112					
F		TS080			GA101		TI001
G		TS081			GA036		TI003

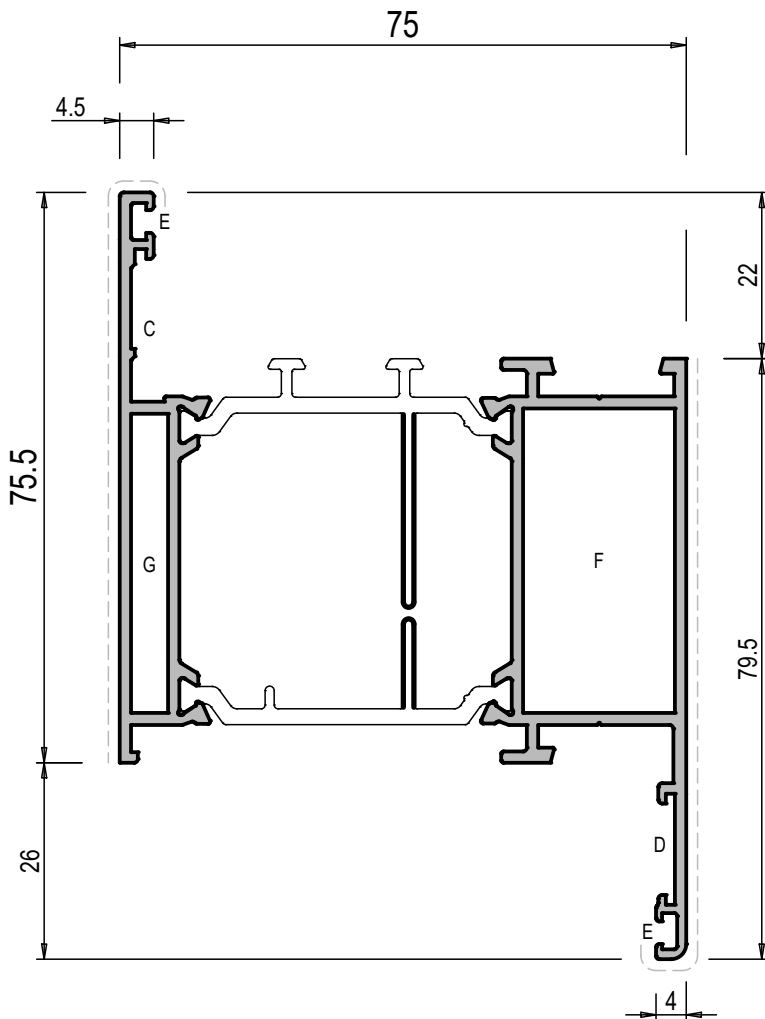

175007

TELAIO MAGGIORATO FISSO "Z"		Jx cm ⁴	28.0
PESO g/m	1749	Jy cm ⁴	40.6
S. VISTA mm	171	Wx cm ³	4.9
		Wy cm ³	10.5

C		G501N				
D		G269				
E		G112				
F		TS080			GA101	
G		TS081			GA036	TI003

Profilati Scala 1:1



TELAIO A MURO

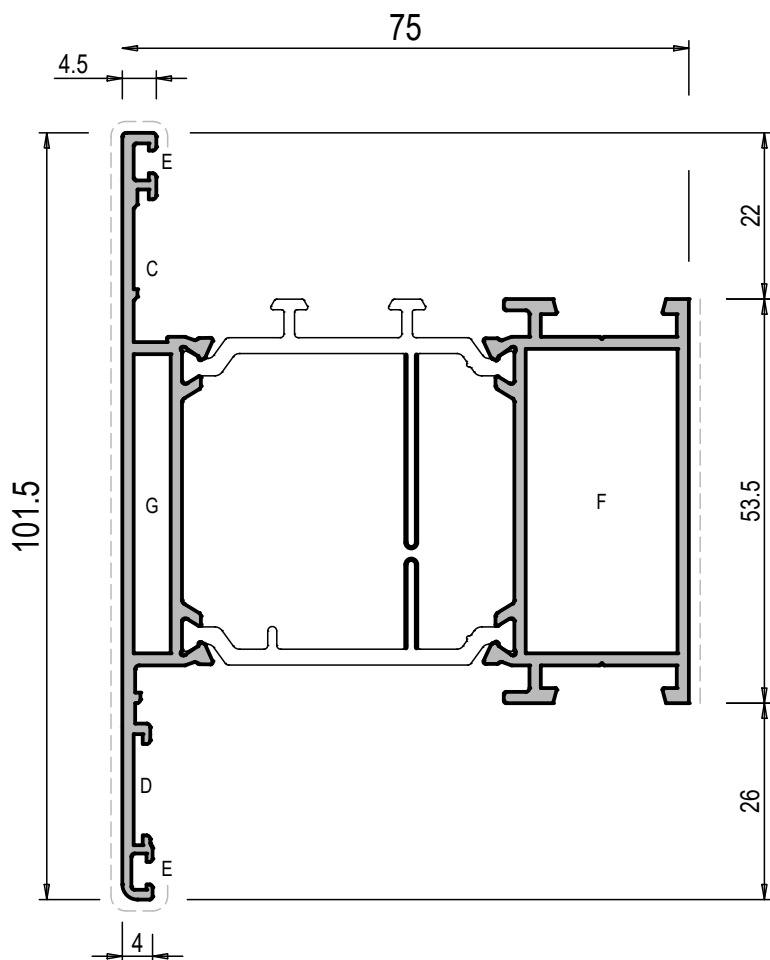

175008

TELAIO MAGGIORATO FISSO "T"		Jx	cm ⁴	28.0	
PESO	g/m	1784	Jy	cm ⁴	39.2
S. VISTA	mm	166	Wx	cm ³	5.6
			Wy	cm ³	9.1

C		G501N				
D		G269				
E		G112				
F		TS080		GA101		TI001
G		TS081				TI003

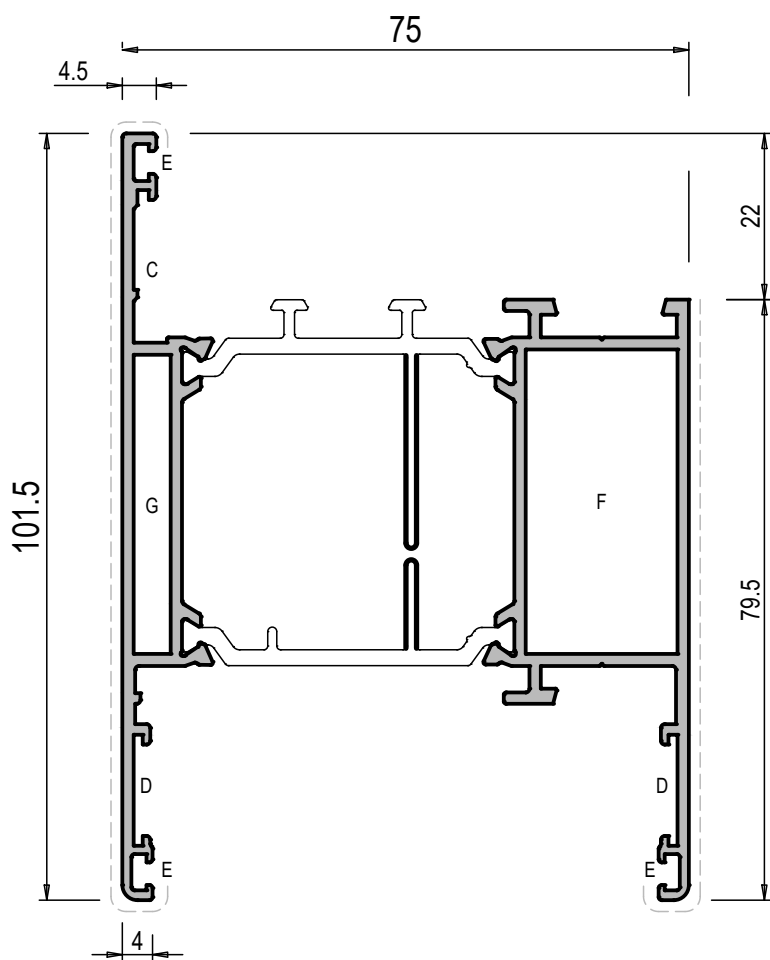

175009

TELAIO MAGGIORATO FISSO "H"		Jx	cm ⁴	x	
PESO	g/m	1884	Jy	cm ⁴	x
S. VISTA	mm	198	Wx	cm ³	x
			Wy	cm ³	x

C		G501N				
D		G269				
E		G112				
F		TS080		GA101		TI001
G		TS081				TI003

TELAIO A MURO

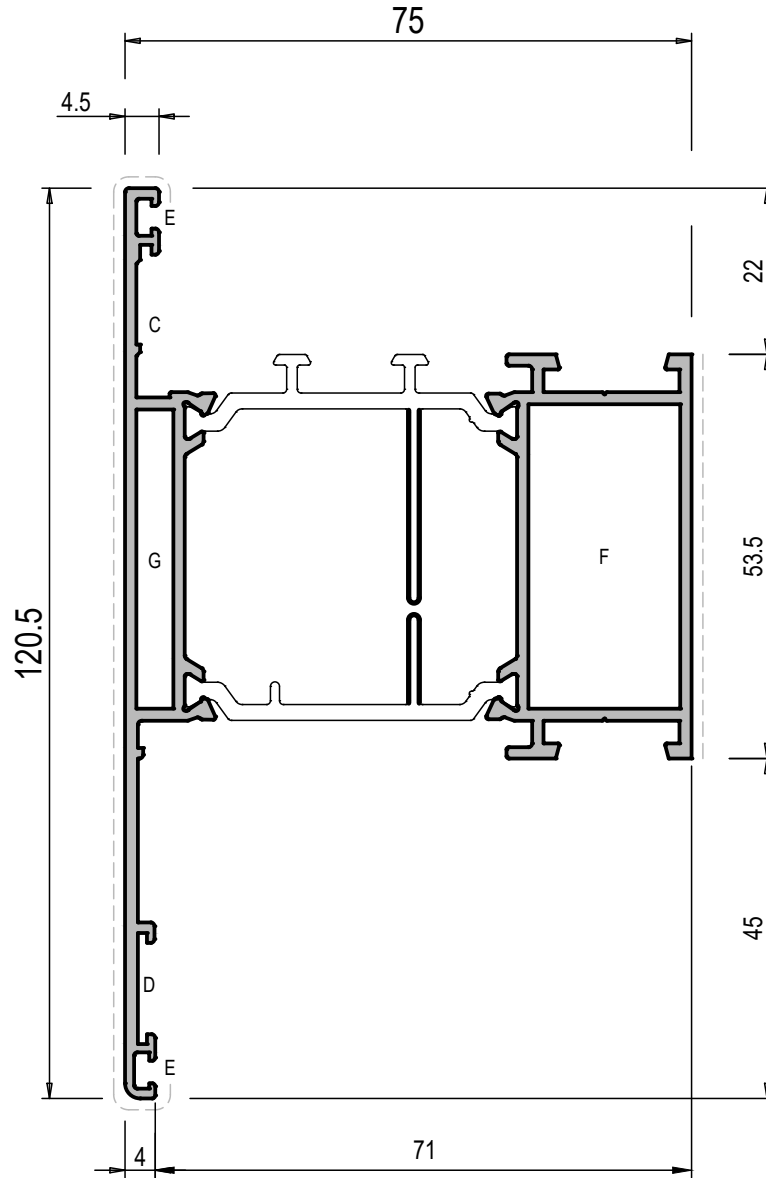

175133

TELAIO MAGGIORATO FISSO "T" ALETTA 45		Jx cm ⁴	37.8
PESO g/m	1882	Jy cm ⁴	41.3
S. VISTA mm	185	Wx cm ³	5.6
		Wy cm ³	9.1

C		G501N				
D		G269				
E		G112				
F		TS080		GA101	T1001	
G		TS081			T1003	

TELAIO A MURO

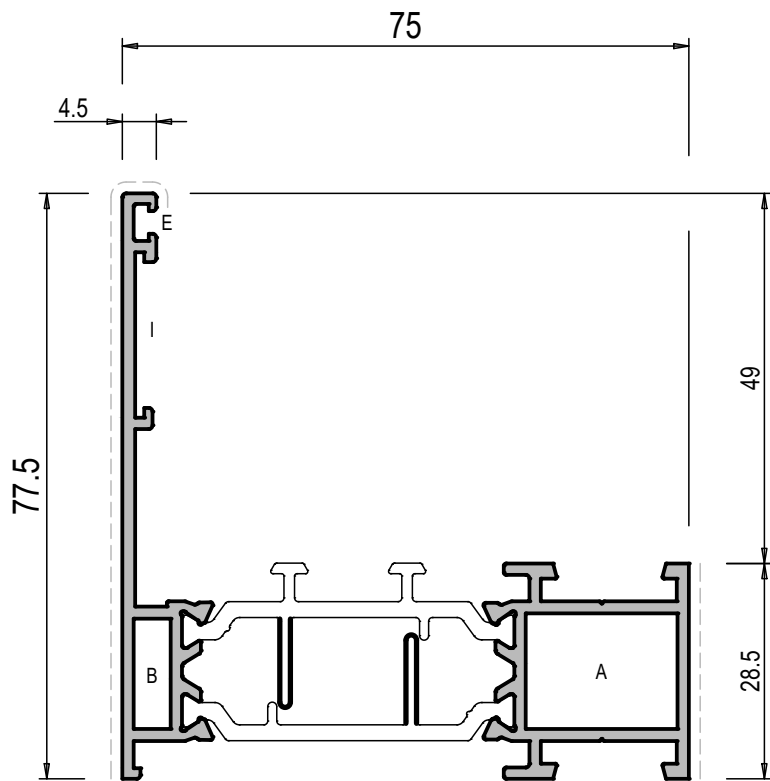

175120

TELAIO ANTA A SCOMPARSA "L"		Jx cm ⁴	13.3
PESO g/m	1379	Jy cm ⁴	29.4
S. VISTA mm	112	Wx cm ³	2.1
		Wy cm ³	6.3

A		TS078		TS077	GA101	TI001
B		TS079			GA036	TI003
I		G267				
E		G112				

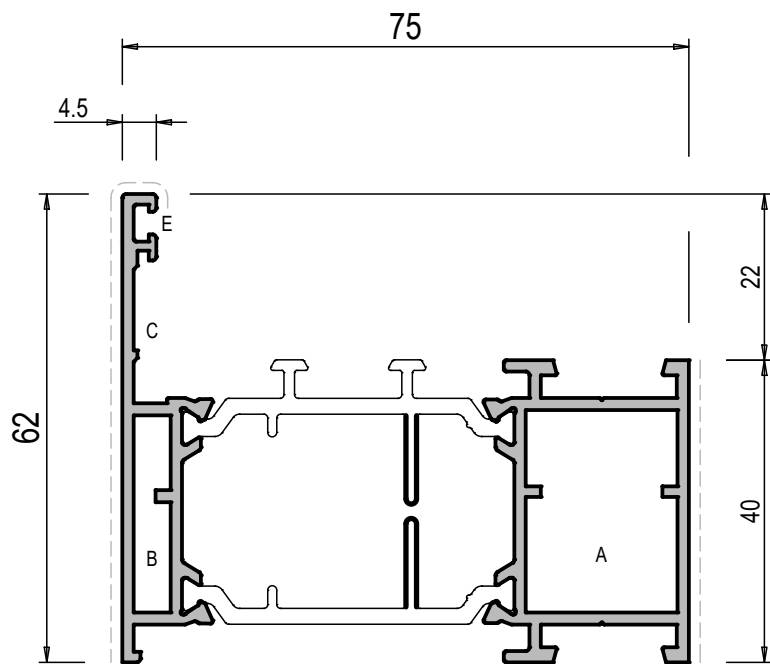

175040

TELAIO SEMI-MAGG. FISSO "L"		Jx cm ⁴	10.5
PESO g/m	1441	Jy cm ⁴	30.8
S. VISTA mm	107	Wx cm ³	2.8
		Wy cm ³	7.7

A		TS078		TS077	GA101	TI001
B		TS079				TI003
C		G501N				
E		G112				

TELAIO A MURO

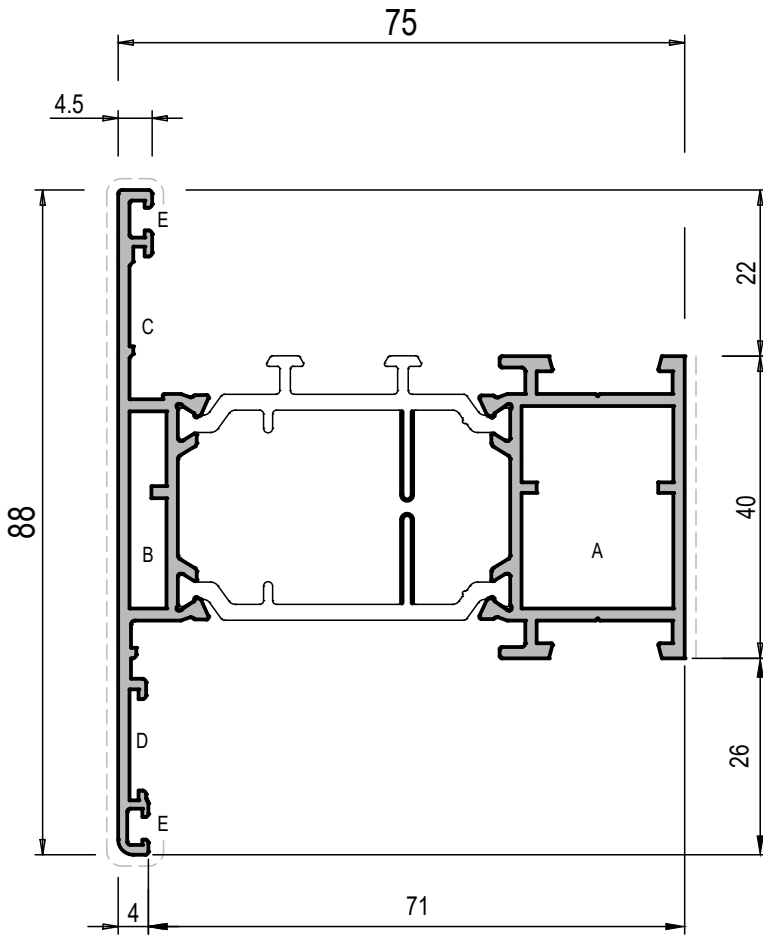

175115

TELAIO SEMI-MAGG. FISSO "T"		Jx cm ⁴	15.4
PESO g/m	1579	Jy cm ⁴	34.3
S. VISTA mm	136.5	Wx cm ³	3.5
		Wy cm ³	7.7

A	TS078	TS077	GA101	TI001
B	TS079		GA036	TI003
C	G501N			
D	G269			
E	G112			

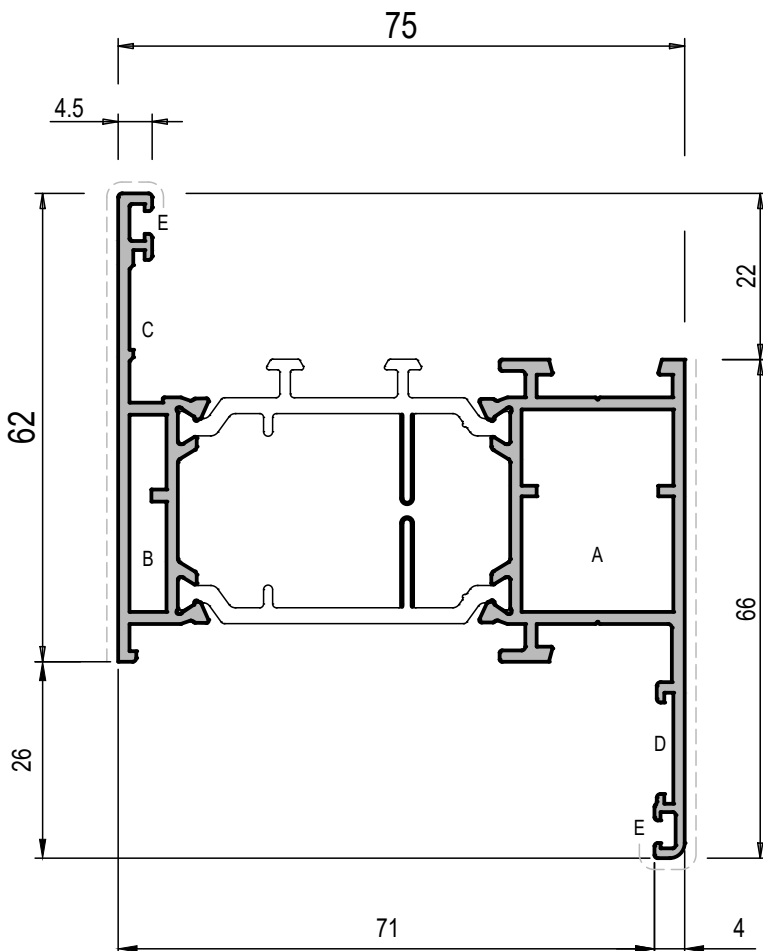

175116

TELAIO SEMI-MAGG. FISSO "Z"		Jx cm ⁴	14.7
PESO g/m	1569	Jy cm ⁴	35.7
S. VISTA mm	136.5	Wx cm ³	3.5
		Wy cm ³	9.1

A	TS078	TS077	GA101	TI001
B	TS079		GA036	TI003
C	G501N			
D	G269			
E	G112			

ANTE

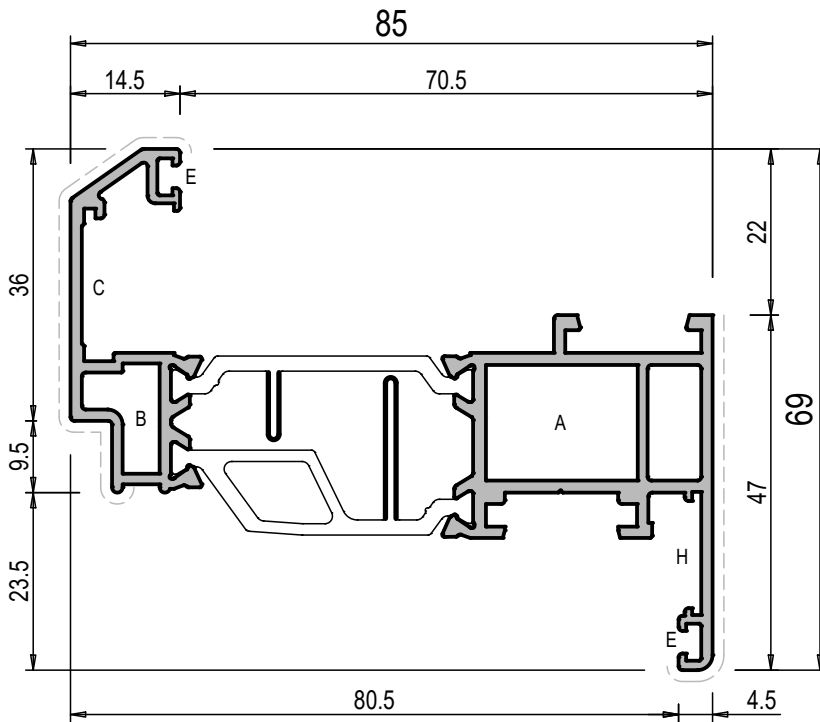

175002

ANTA "Z" SGUSCIATA		Jx	cm ⁴	8.4	
PESO	g/m	1549	Jy	cm ⁴	37.8
S. VISTA	mm	113	Wx	cm ³	2.1
			Wy	cm ³	8.4

A	TS078	TS077	GA101	TI001
B	TS079		GA036	TI003
C	G501N			
E	G112			
H	G268			

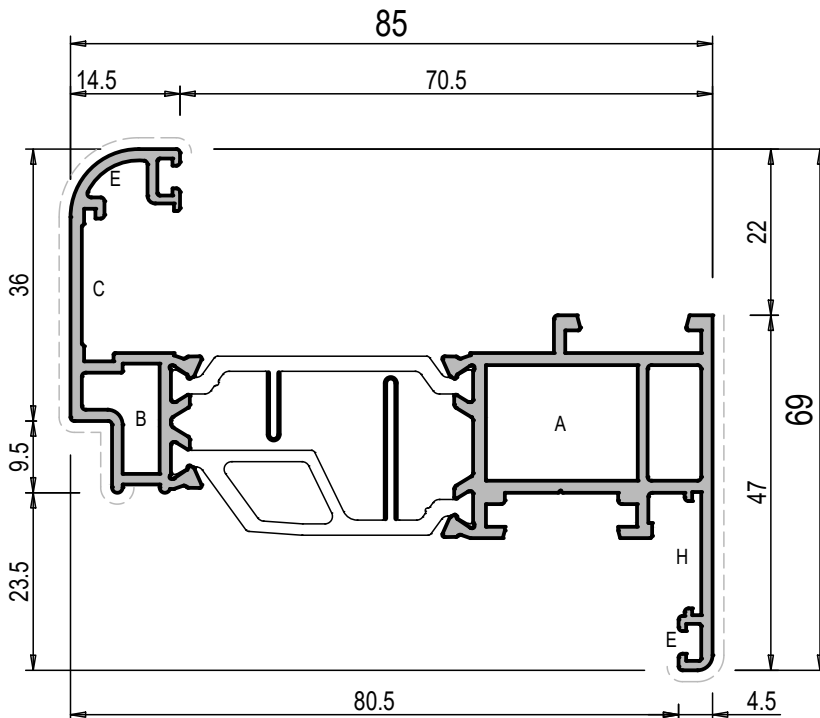

175039





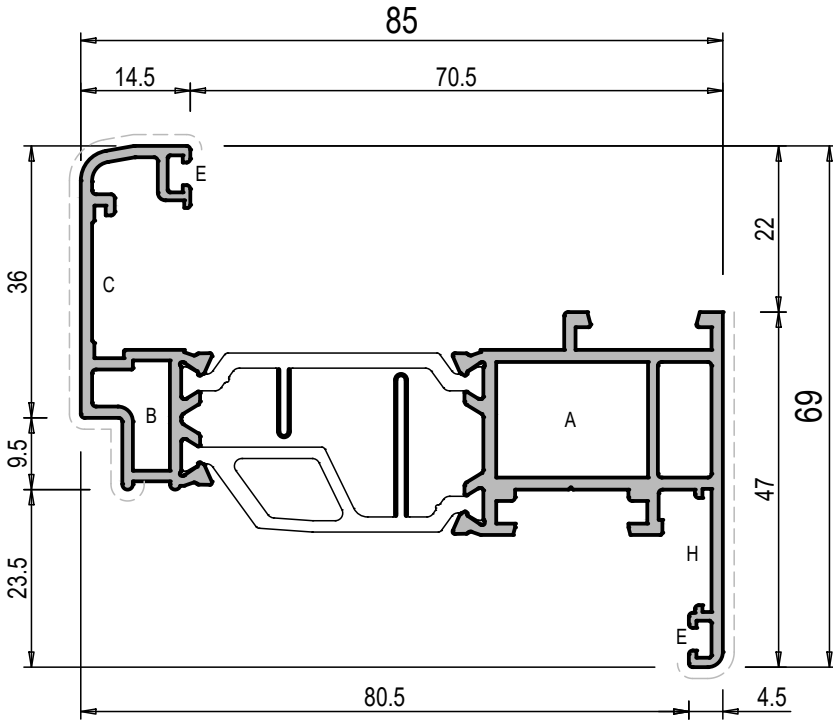

ANTA "Z" ARROTONDATA		Jx	cm ⁴	9.1	
PESO	g/m	1553	Jy	cm ⁴	37.8
S. VISTA	mm	112	Wx	cm ³	2.8
			Wy	cm ³	8.4

A	TS078	TS077	GA101	TI001
B	TS079		GA036	TI003
C	G501N			
E	G112			
H	G268			



175050





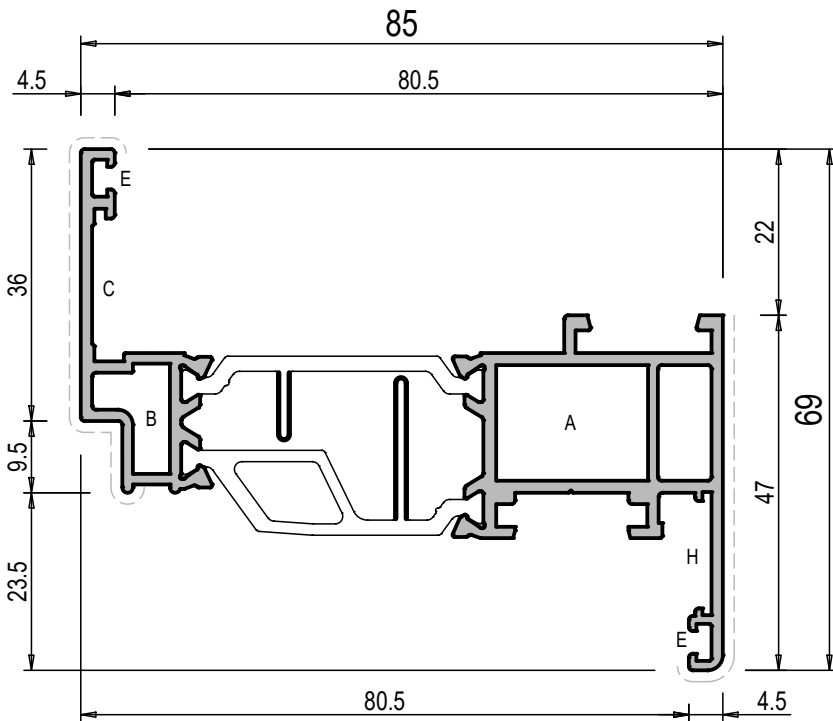

ANTA "Z" STORICA		Jx cm ⁴	9.1
PESO g/m	1560	Jy cm ⁴	38.5
S. VISTA mm	116	Wx cm ³	2.8
		Wy cm ³	8.4

A	 TS078	 TS077	GA101	TI001
B	 TS079		GA036	TI003
C	 G501N			
E	 G112			
H	 G268			



175010

ANTA "Z" PIANA		Jx cm ⁴	7.0
PESO g/m	1499	Jy cm ⁴	37.1
S. VISTA mm	106	Wx cm ³	2.1
		Wy cm ³	8.4

A	 TS078	 TS077	GA101	TI001
B	 TS079		GA036	TI003
C	 G501N			
E	 G112			
H	 G268			

ANTE

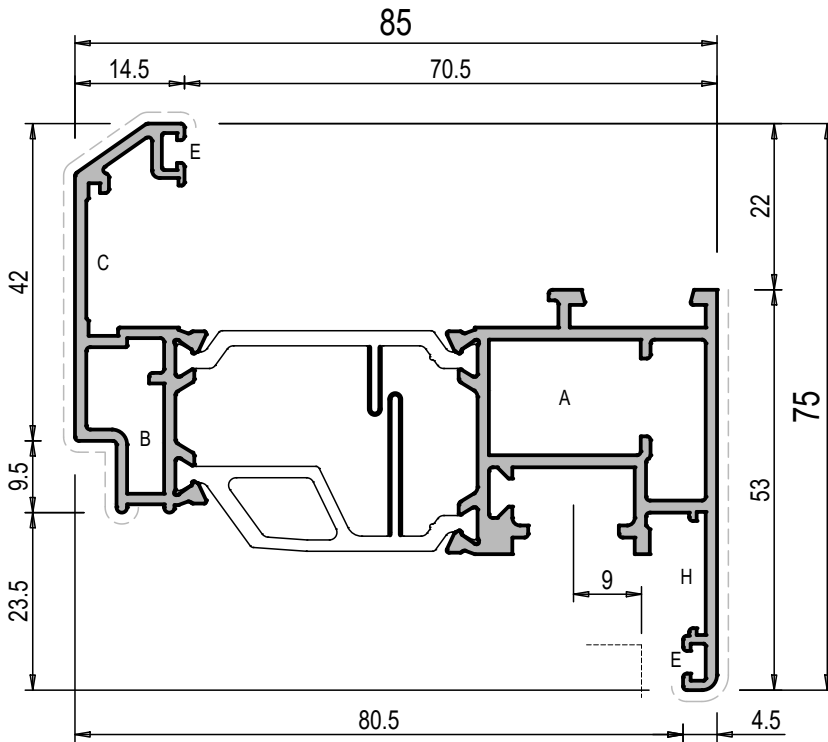

175012

ANTA PISTA 16 SGUSCIATA			Jx cm ⁴	11.9
PESO g/m	1680		Jy cm ⁴	41.3
S. VISTA mm	124		Wx cm ³	2.8
			Wy cm ³	9.8

A		TS078		TS077	GA101	TI001
B		TS079			GA036	TI003
C		G501N				
E		G112				
H		G268				

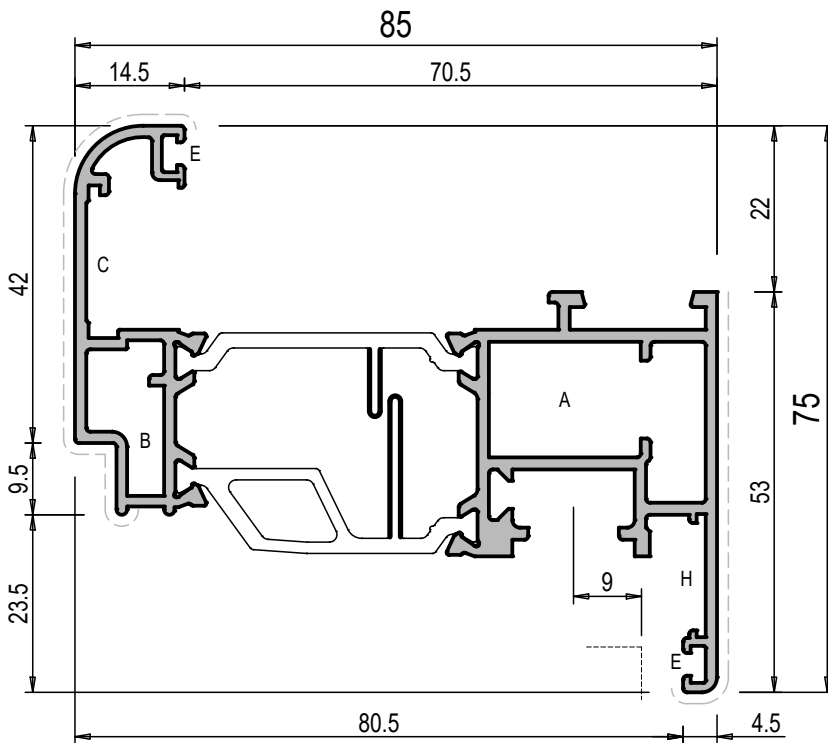

175056





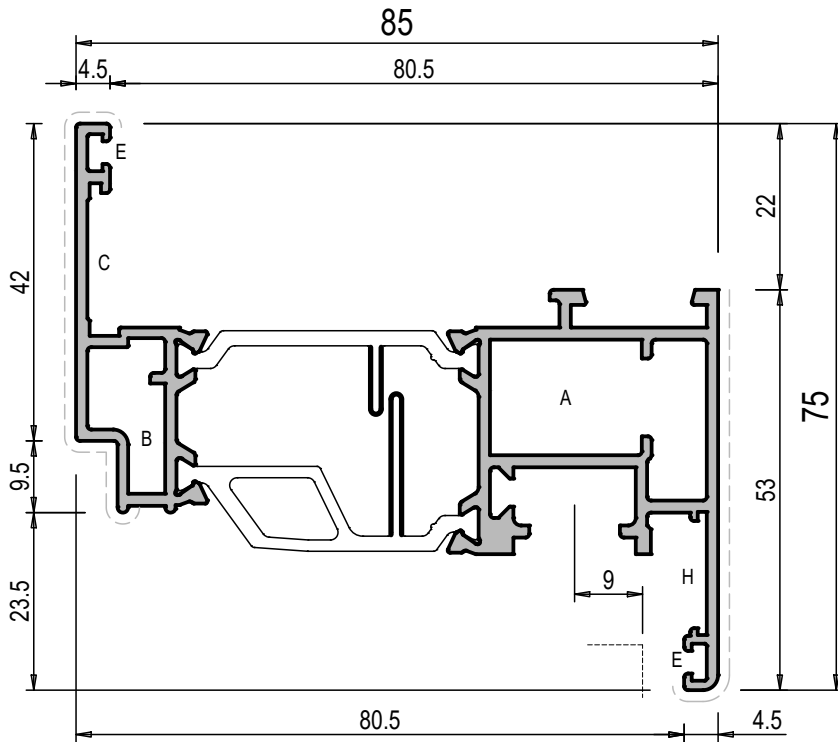

ANTA PISTA 16 ARROTONDATA			Jx cm ⁴	12.6
PESO g/m	1684		Jy cm ⁴	42.0
S. VISTA mm	125.5		Wx cm ³	3.5
			Wy cm ³	9.8

A		TS078		TS077	GA101	TI001
B		TS079			GA036	TI003
C		G501N				
E		G112				
H		G268				



175081



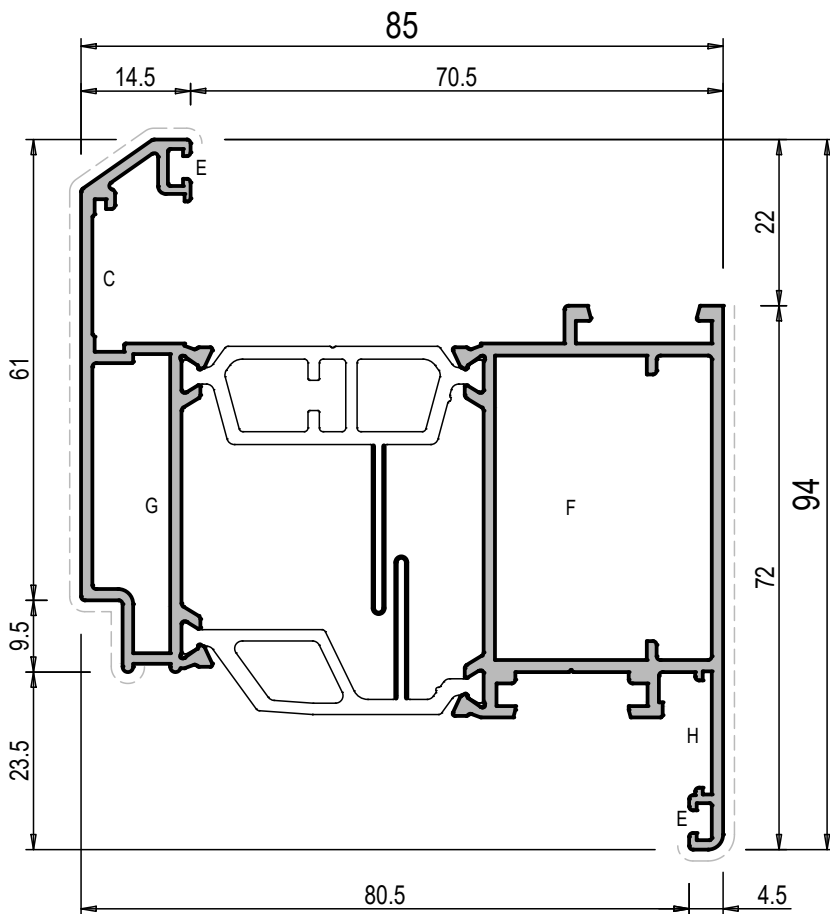

ANTA PISTA 16 PIANA		Jx	cm ⁴	10.5	
PESO	g/m	1631	Jy	cm ⁴	40.6
S. VISTA	mm	115	Wx	cm ³	2.8
			Wy	cm ³	9.8

A		TS078		TS077	GA101	TI001
B		TS079			GA036	TI003
C		G501N				
E		G112				
H		G268				



175014

ANTA MAGGIORATA SGUSCIATA		Jx	cm ⁴	30.8	
PESO	g/m	2016	Jy	cm ⁴	50.4
S. VISTA	mm	162	Wx	cm ³	6.3
			Wy	cm ³	11.2

C		G501N				
E		G112				
F		TS080			GA101	TI001
G		TS081			GA036	TI003
H		G268				

ANTE

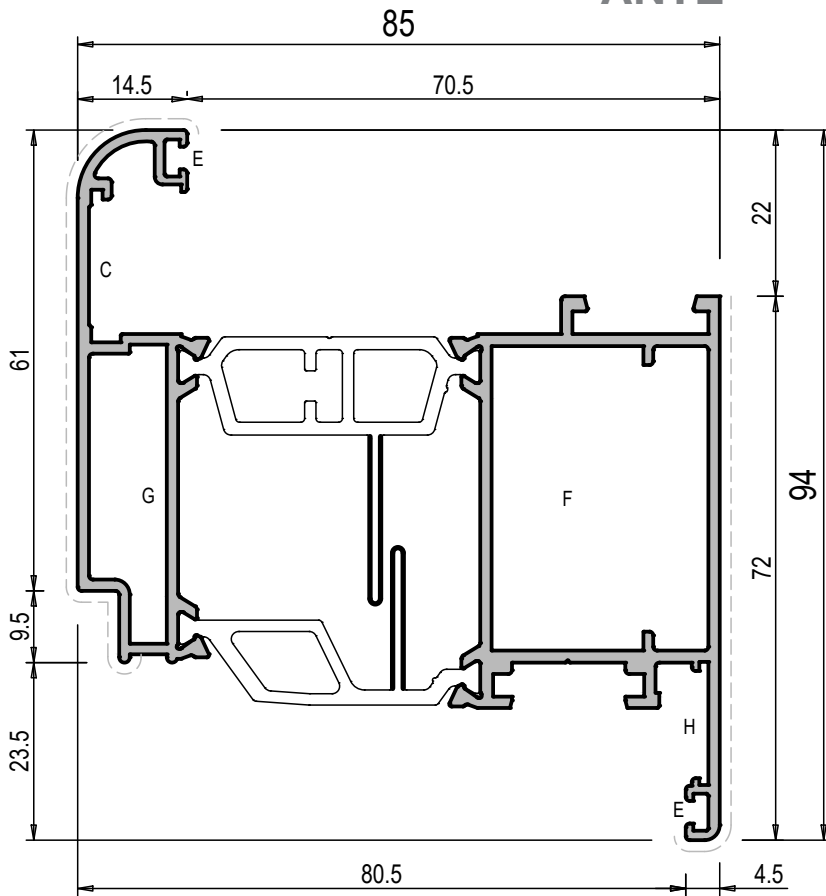

175057

ANTA MAG. ARROTONDATA		Jx	cm ⁴	31.5	
PESO	g/m	2016	Jy	cm ⁴	50.4
S. VISTA	mm	164.5	Wx	cm ³	6.3
			Wy	cm ³	11.2

C	G501N					
E	G112					
F	TS080			GA101		TI001
G	TS081			GA036		TI003
H	G268					

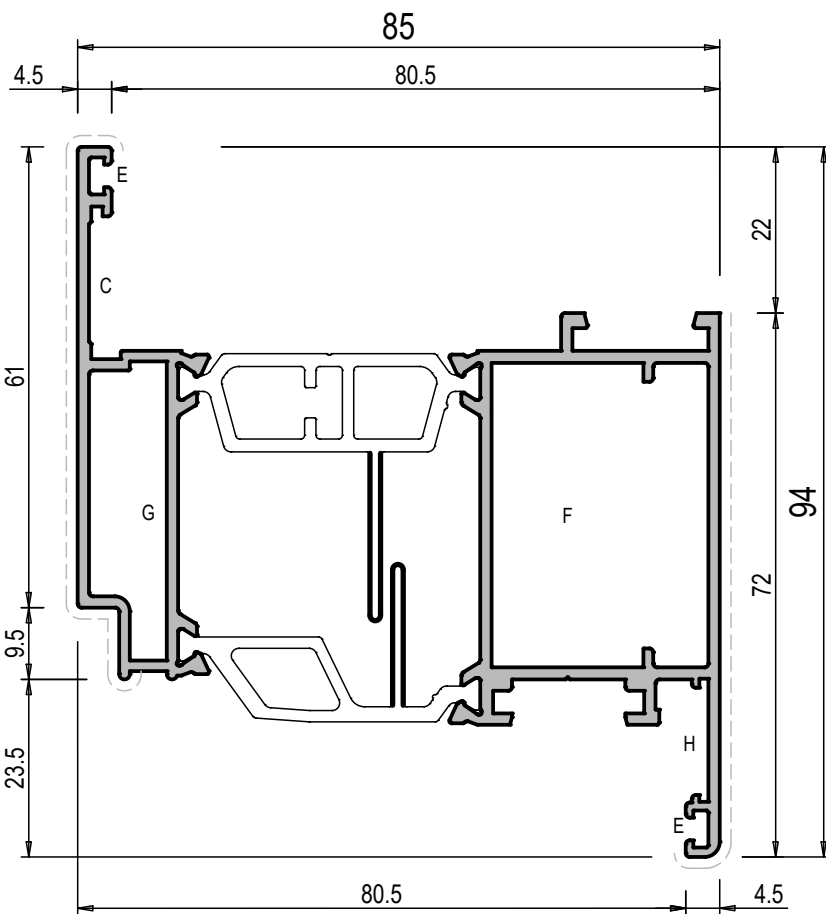

175058

ANTA MAGGIORATA "Z" PIANA		Jx	cm ⁴	28.7	
PESO	g/m	1963	Jy	cm ⁴	49.7
S. VISTA	mm	158	Wx	cm ³	5.6
			Wy	cm ³	11.2





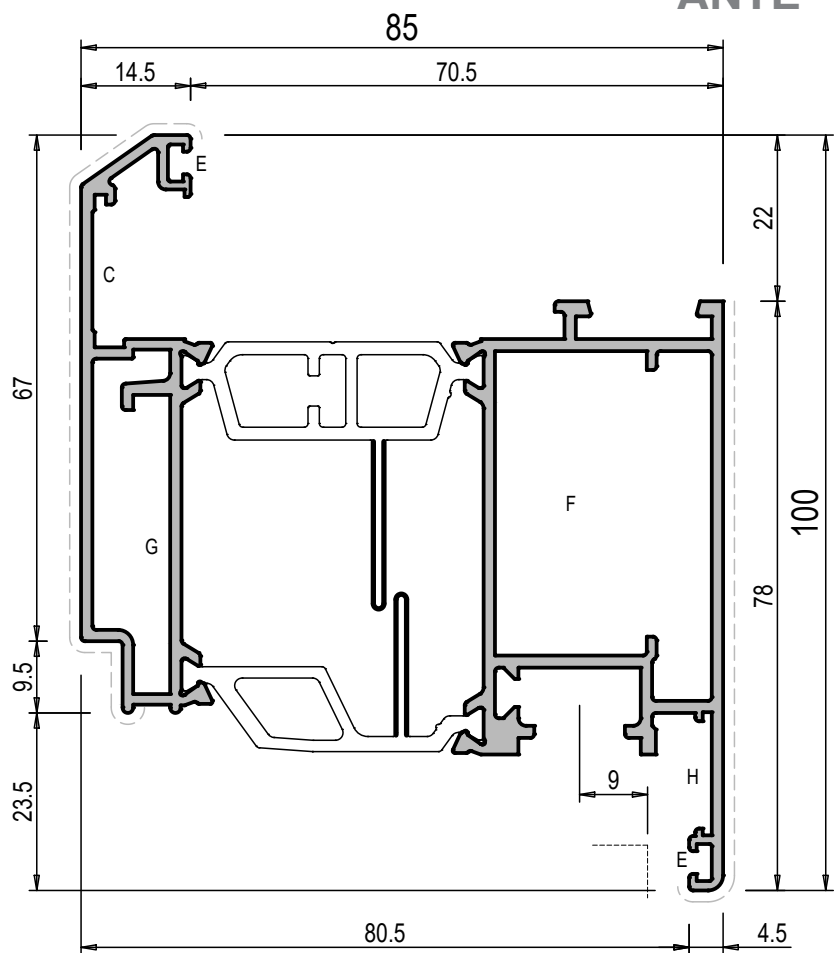

C	G501N					
E	G112					
F	TS080			GA101		TI001
G	TS081			GA036		TI003
H	G268					

ANTE



175051





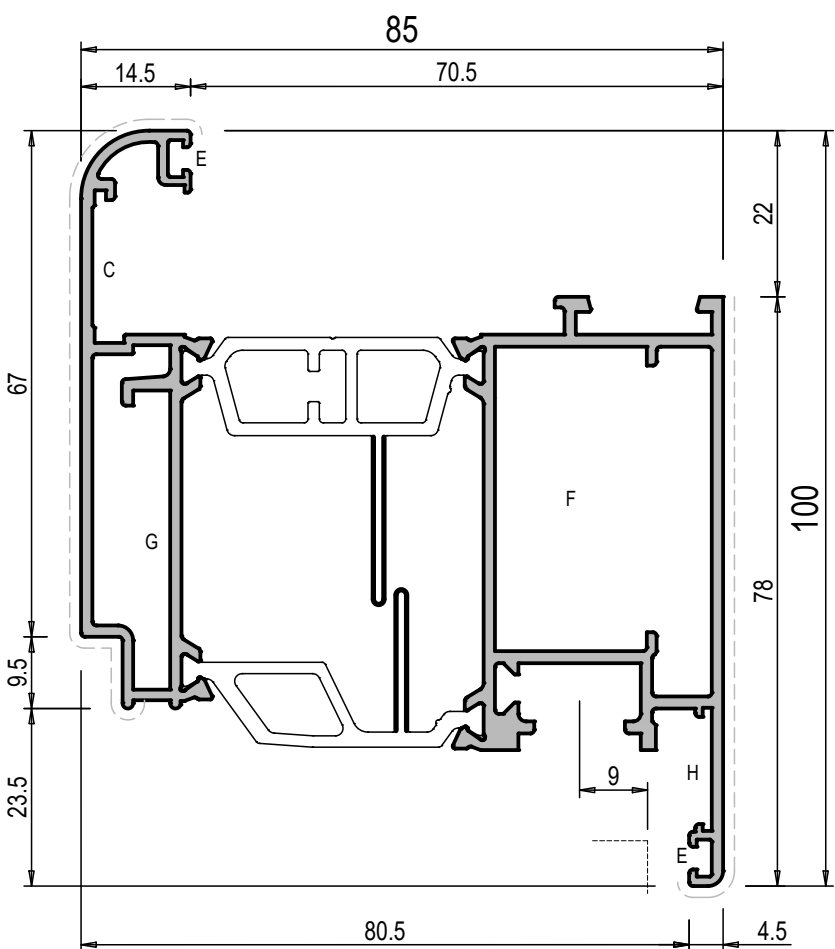

ANTA MAG.PISTA 16 SGUSCIATA		Jx	cm ⁴	39.9	
PESO	g/m	2233	Jy	cm ⁴	55.3
S. VISTA	mm	175.5	Wx	cm ³	7.7
			Wy	cm ³	11.9

C		G501N					
E		G112					
F		TS080			GA101		TI001
G		TS081			GA036		TI003
H		G268					



175059

ANTA MAG. PISTA 16 ARROT.		Jx	cm ⁴	39.9	
PESO	g/m	2237	Jy	cm ⁴	55.3
S. VISTA	mm	176.5	Wx	cm ³	7.7
			Wy	cm ³	12.6

C		G501N					
E		G112					
F		TS080			GA101		TI001
G		TS081			GA036		TI003
H		G268					

ANTE

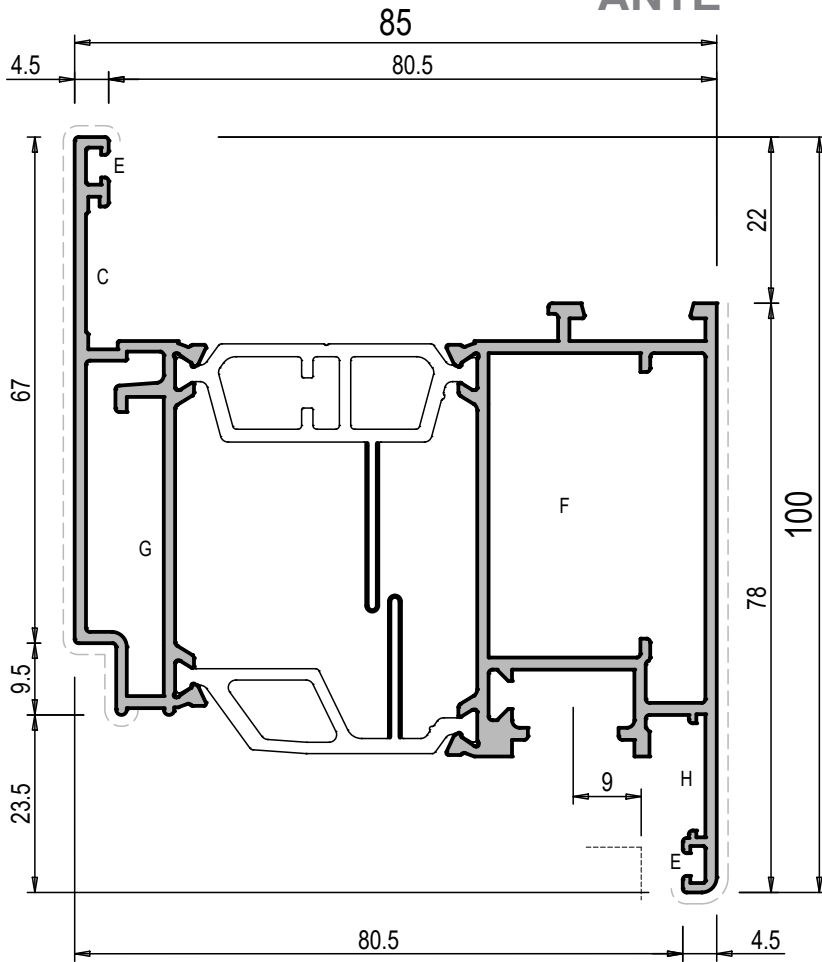

175084

ANTA MAG. PISTA 16 PIANA		Jx	cm ⁴	37.1	
PESO	g/m	2183	Jy	cm ⁴	54.6
S. VISTA	mm	166	Wx	cm ³	7.0
			Wy	cm ³	11.9

C	G501N					
E	G112					
F	TS080			GA101		TI001
G	TS081			GA036		TI003
H	G268					

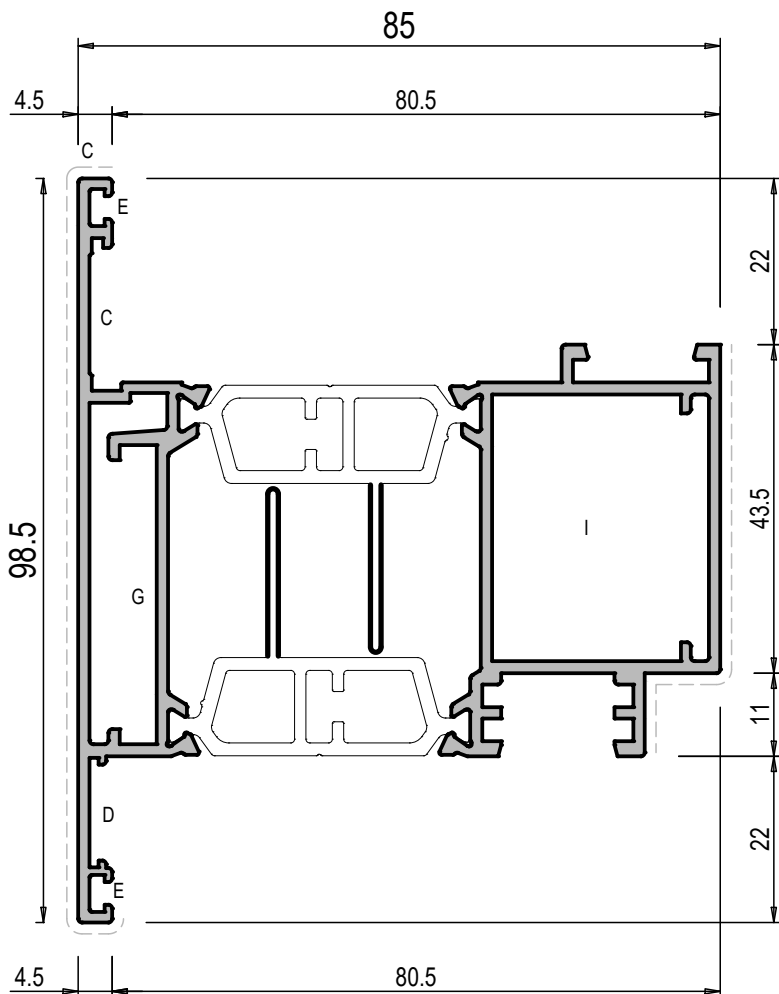

175114



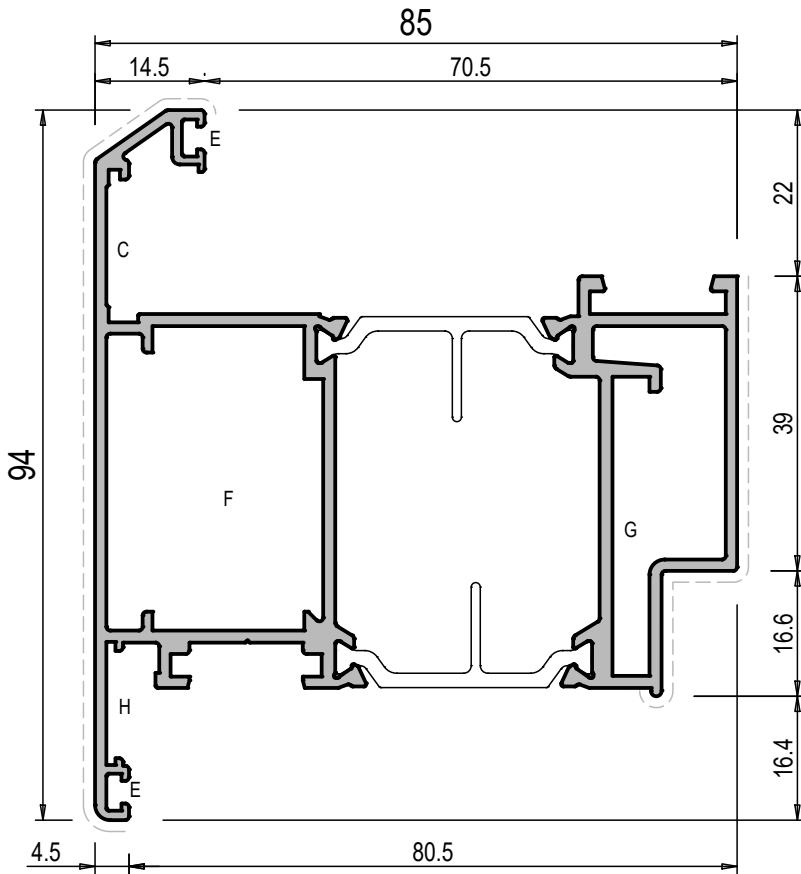

ANTA APERTURA BILICO PIANA		Jx	cm ⁴	32.2	
PESO	g/m	2165	Jy	cm ⁴	51.1
S. VISTA	mm	165	Wx	cm ³	6.3
			Wy	cm ³	9.8

C	G501N					
D	G269					
E	G112			GA101		TI001
G	TS081			GA036		TI003
I	G2007					



175126



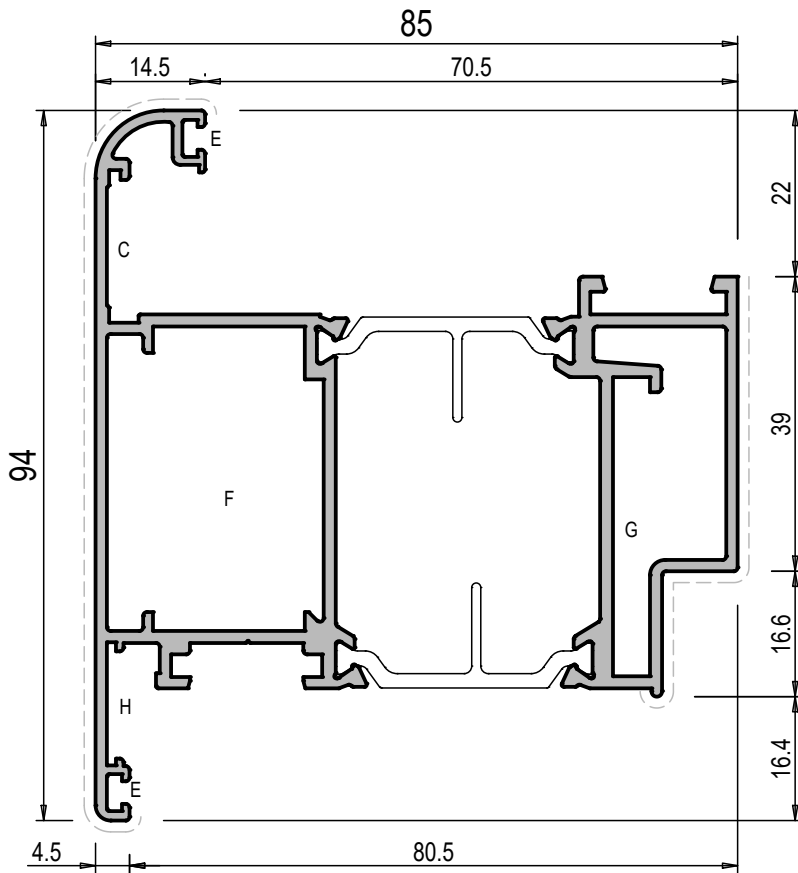

ANTA APERTURA EST. MAG. SGUSCIATA DOPPIA BATTUTA		Jx cm ⁴	31.5
PESO g/m	2108	Jy cm ⁴	49.7
S. VISTA mm	169	Wx cm ³	6.3
		Wy cm ³	11.2

C		G501N					
E		G112					
F		TS080			GA101	TI001	
G		TS081			GA036	TI003	
H		G268					



175127

ANTA APERTURA EST. MAG. ARROT. DOPPIA BATTUTA		Jx cm ⁴	31.5
PESO g/m	2111	Jy cm ⁴	49.7
S. VISTA mm	169	Wx cm ³	6.3
		Wy cm ³	11.2

C		G501N					
E		G112					
F		TS080			GA101	TI001	
G		TS081			GA036	TI003	
H		G268					

ANTE

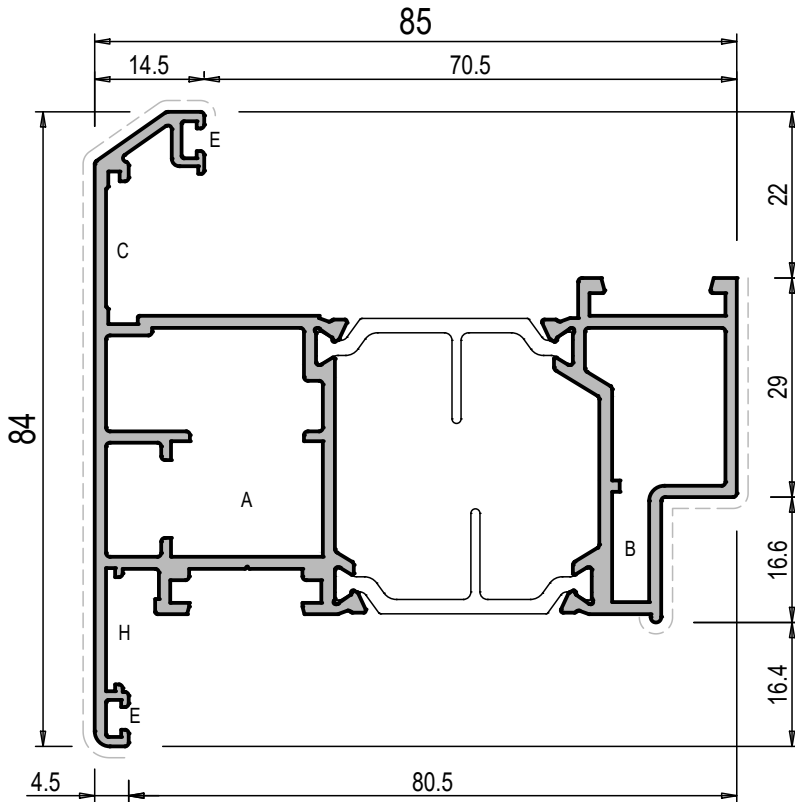

175128

ANTA APERTURA ESTERNA SGUSCIATA DOPPIA BATTUTA		Jx cm ²	20.3
PESO g/m	1920	Jy cm ⁴	44.8
S. VISTA mm	169	Wx cm ³	4.9
		Wy cm ³	9.8

C	G501N					
E	G112					
F	TS080			GA101		TI001
G	TS081			GA036		TI003
H	G268					

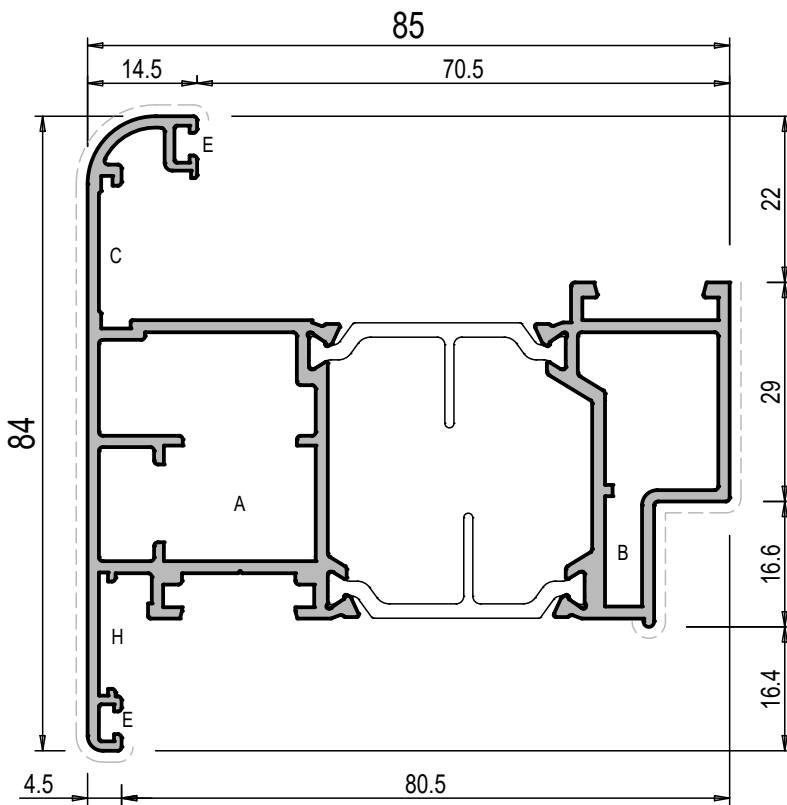

175129

ANTA APERTURA ESTERNA ARROT. DOPPIA BATTUTA		Jx cm ²	20.3
PESO g/m	1924	Jy cm ⁴	44.8
S. VISTA mm	169	Wx cm ³	4.9
		Wy cm ³	9.8

C	G501N					
E	G112					
F	TS080			GA101		TI001
G	TS081			GA036		TI003
H	G268					

ANTE

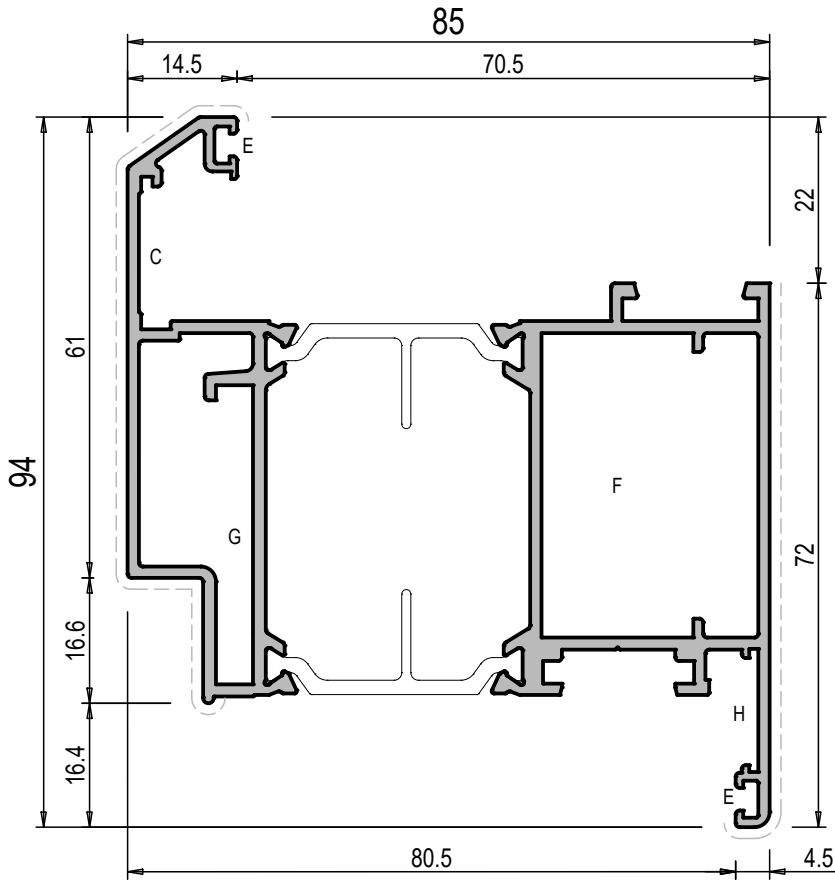

175130

ANTA APERTURA INT. MAG. SGUSCIATA DOPPIA BATTUTA		Jx cm ⁴	31.5
PESO g/m	2068	Jy cm ⁴	49
S. VISTA mm	169	Wx cm ³	6.3
		Wy cm ³	11.2

C		G501N					
E		G112					
F		TS080			GA101	TI001	
G		TS081			GA036	TI003	
H		G268					

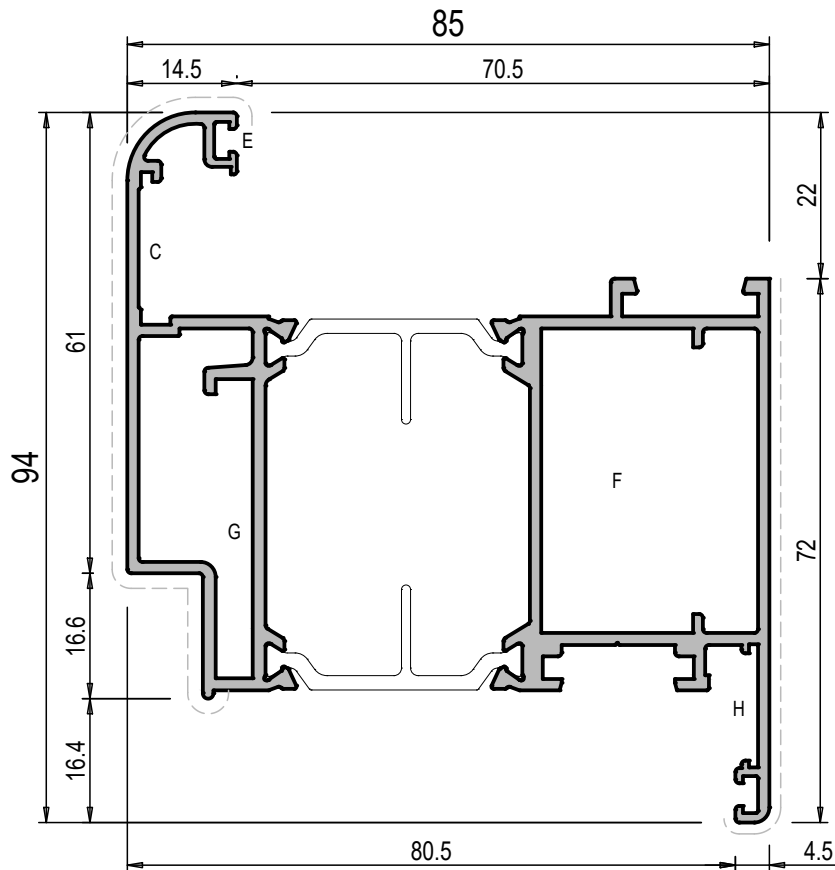

175131

ANTA APERTURA INT. MAG. ARROT. DOPPIA BATTUTA		Jx cm ⁴	31.5
PESO g/m	2160	Jy cm ⁴	49
S. VISTA mm	169	Wx cm ³	6.3
		Wy cm ³	11.2

C		G501N					
E		G112					
F		TS080			GA101	TI001	
G		TS081			GA036	TI003	
H		G268					

ANTE

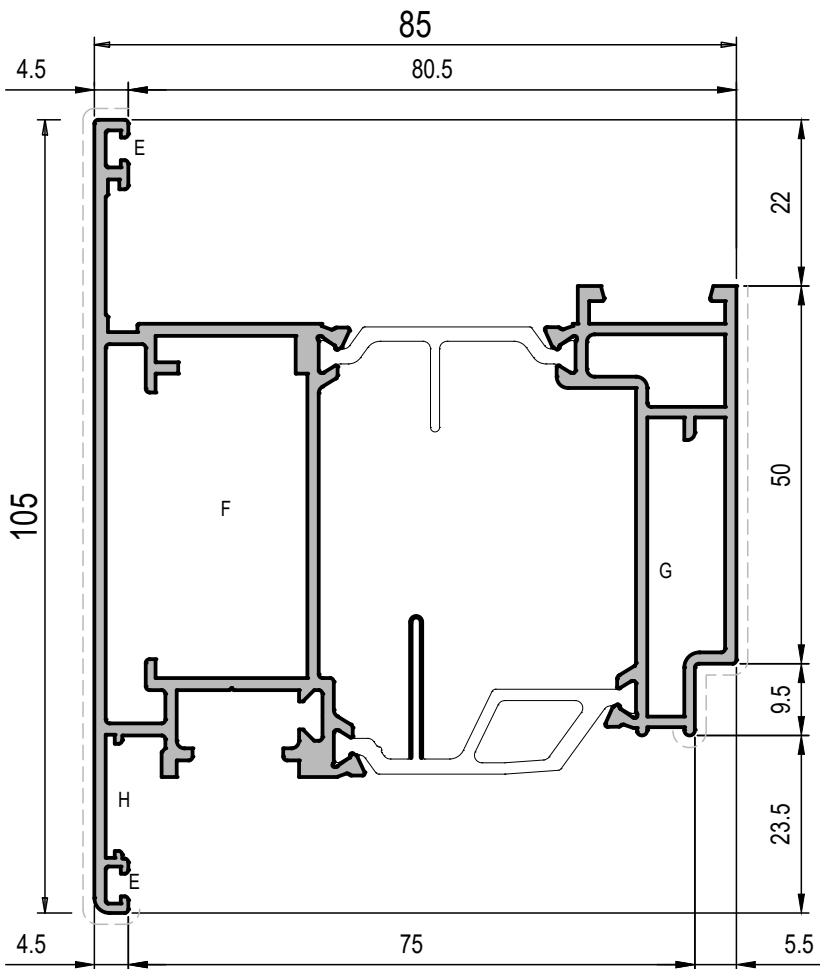

175113

ANTA APERTURA EST. MAG. PIANA P.16 DOPPIA BATTUTA			Jx	43.4	
PESO	2244		Jy	51.1	
S. VISTA	179		Wx	7.7	
			Wy	12.6	
C	G501N				
E	G112				
F	TS080		GA101		T1001
G	TS081		GA036		T1003
H	G268				

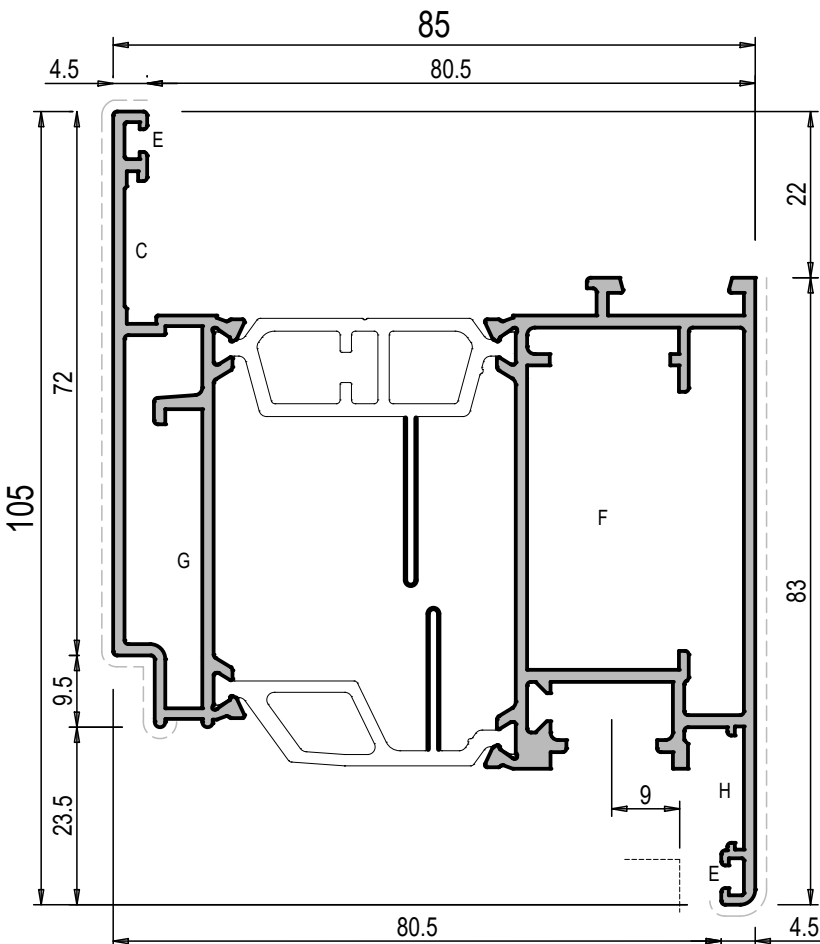

175117

ANTA MAG.PISTA 16 PIANA			Jx	44.8	
PESO	2378		Jy	57.4	
S. VISTA	175.5		Wx	8.4	
			Wy	12.6	
C	G501N				
E	G112				
F	TS080		GA101		T1001
G	TS081		GA036		T1003
H	G268				

ANTA A SCOMPARSA

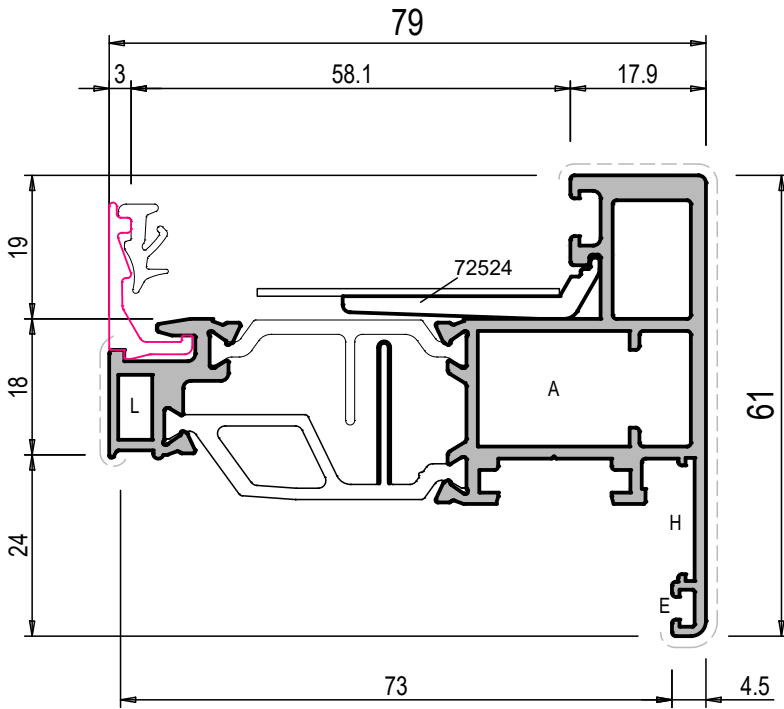

175121

ANTA "Z" A SCOMPARSA		Jx cm ⁴	8.4
PESO g/m	1611	Jy cm ⁴	34.3
S. VISTA mm	96	Wx cm ³	2.8
		Wy cm ³	7.7
A	TS078	TS077	GA101
E	G112		
H	G268		
L	TS206		

N.B. SOLO SOLUZIONE AD 1 ANTA

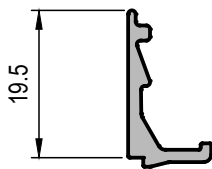

665438

FERAVETRO ANTA A SCOMPARSA		Jx cm ⁴	.
PESO g/m	161	Jy cm ⁴	.
S. VISTA mm	----	Wx cm ³	.
		Wy cm ³	.

Profilati Scala 1:1



ANTE

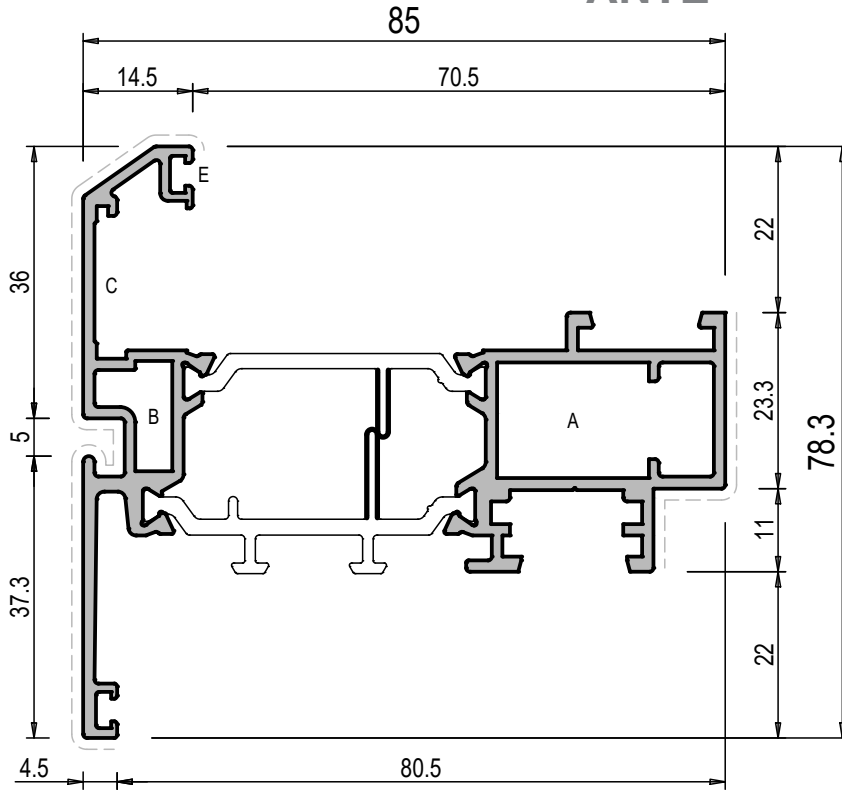

175011

ANTA "T" SGUSCIATA		Y	Jx	11.9	
PESO	1699		Jy	40.6	
S. VISTA	150		Wx	2.8	
			Wy	8.4	
A	TS078		Y	TT060	CP. TAPPI
B	TS079		Y1	TT069	CP. TAPPI
C	G501N				
E	G112				
H	G268				

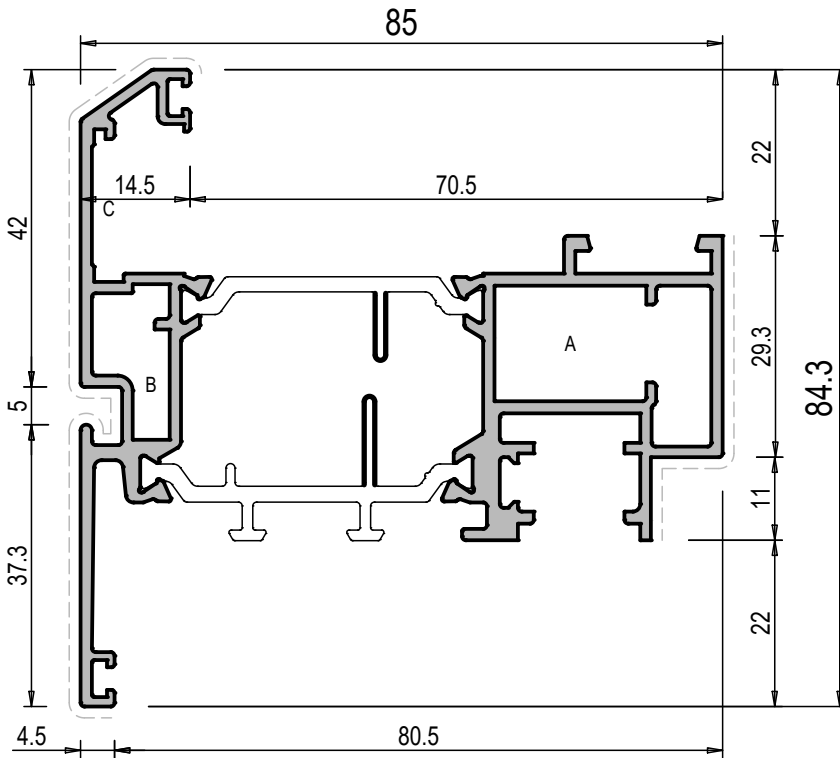

175095

ANTA "T" SGUSCIATA PISTA 16		Y	Jx	16.8	
PESO	1878		Jy	44.8	
S. VISTA	150		Wx	4.2	
			Wy	9.1	
A	TS078		Y	TT067	CP. TAPPI
B	TS079		Y1	TT069	CP. TAPPI
C	G501N				
E	G112				
H	G268				

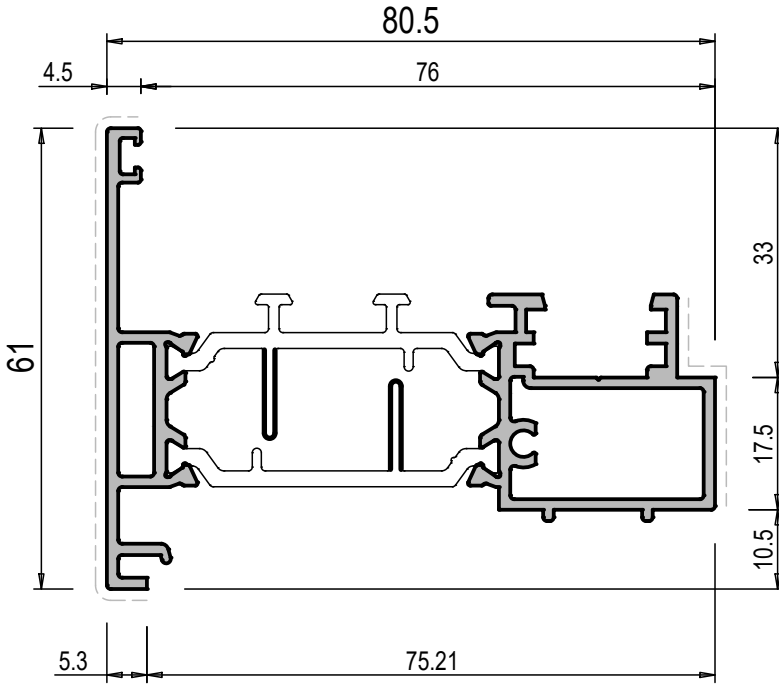

175003

RIPORTO PIANO		Jx	6.3
PESO	1387	Jy	30.8
S. VISTA	102	Wx	2.1
mm		Wy	6.3
J	TT085	CP. TAPPI	

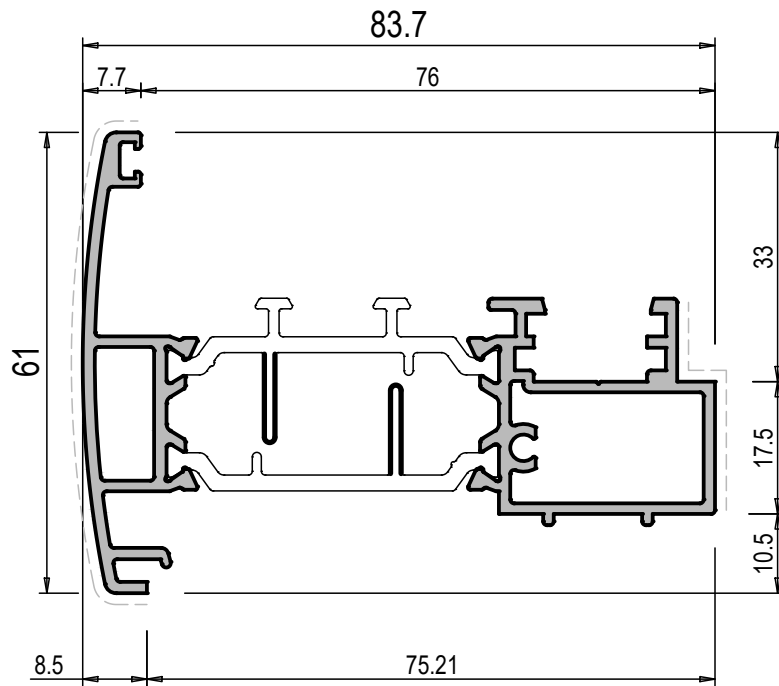

175017

RIPORTO ARROTONDATO		Jx	7.0
PESO	1440	Jy	33.6
S. VISTA	102	Wx	2.1
mm		Wy	7.0
J	TT085	CP. TAPPI	

RIPORTI

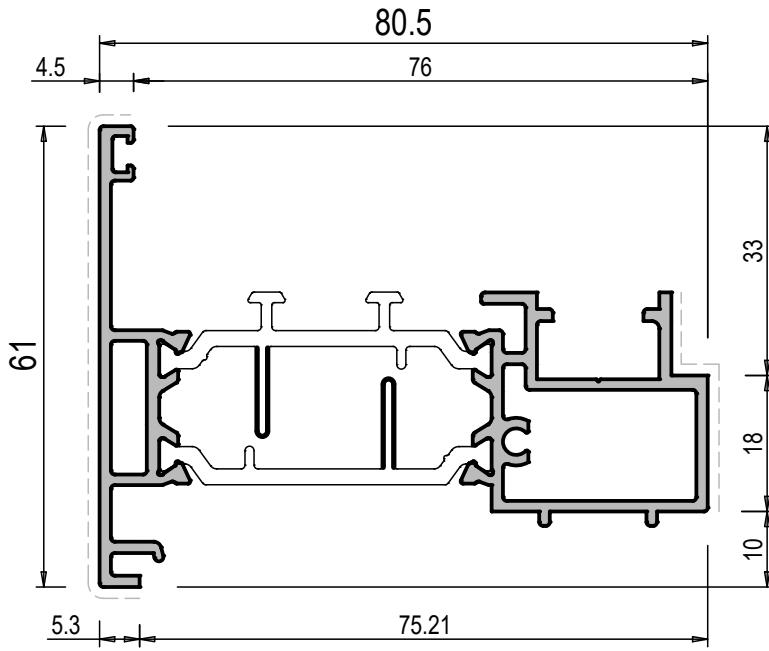

175018

RIPORTO PIANO PISTA 16 INT. 9		Jx cm ⁴	6.3
PESO g/m	1395	Jy cm ⁴	30.8
S. VISTA mm	104	Wx cm ³	2.1
		Wy cm ³	6.3

K	TT086	CP. TAPPI		

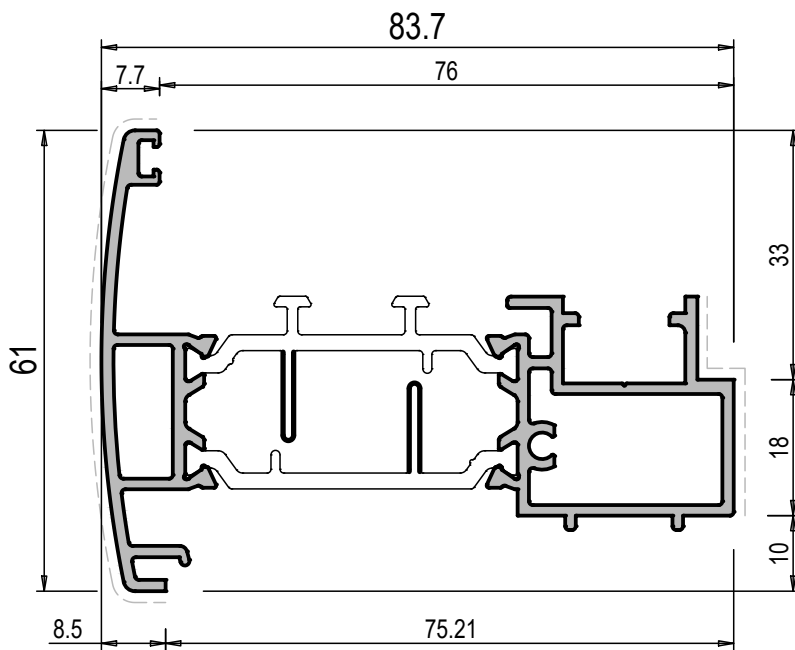



175065

RIPORTO ARROT. PISTA 16 INT. 9		Jx cm ⁴	7.0
PESO g/m	1448	Jy cm ⁴	33.6
S. VISTA mm	104	Wx cm ³	2.1
		Wy cm ³	7.0

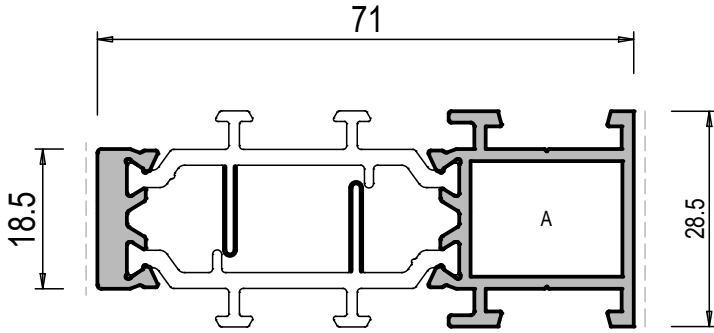
K	TT086	CP. TAPPI		







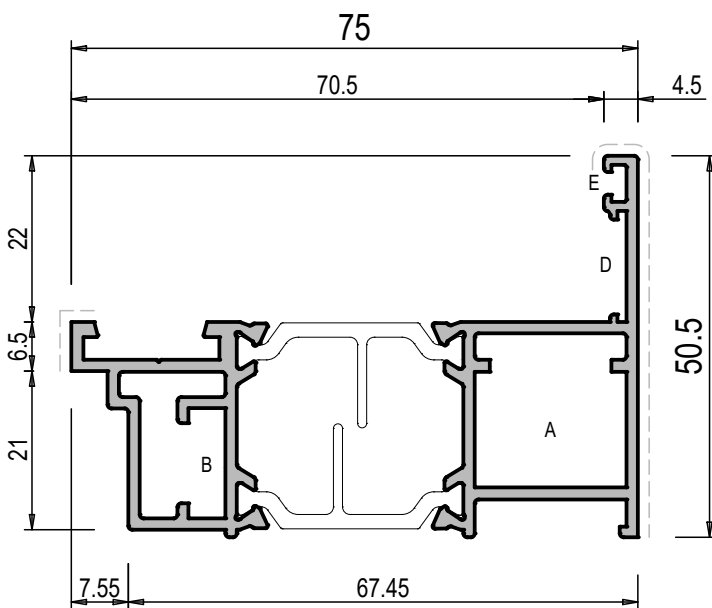

175122

RIPORTO ANTA A SCOMPARSA		Jx	4.9
PESO	1089	Jy	20.3
S. VISTA	47	Wx	2.1
		Wy	2.8
A	 TS078	 TS077	GA101
			TI001
			GA036
			TI003
			



175066

RIPORTO APERTURA ESTERNA INSERIMENTO IN VETRINA		Jx	5.6
PESO	1289	Jy	21.0
S. VISTA	62	Wx	1.4
		Wy	4.9
A	 TS078	 TS077	GA101
B	 TS079		TI001
D	 G269		GA036
E	 G112		TI003
			

RIPORTI

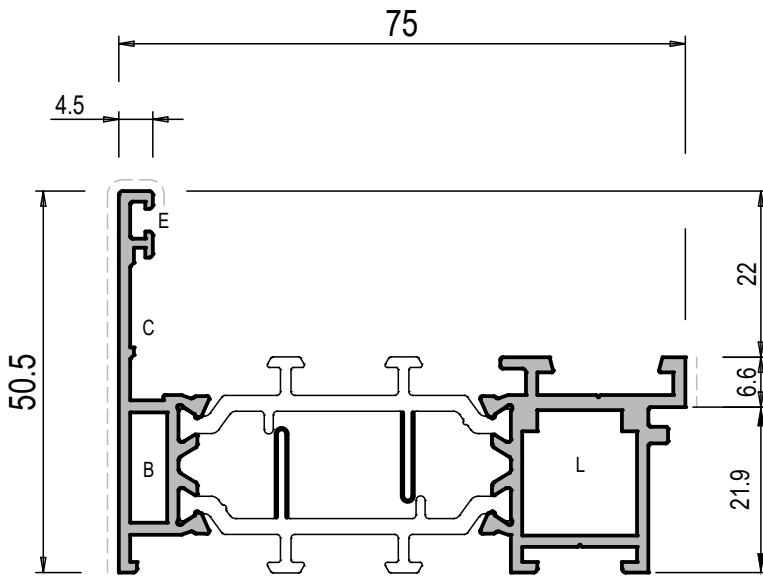

175119

RIPORTO		Jx	4.9
PESO	1268	Jy	25.2
S. VISTA	61.5	Wx	1.4
		Wy	6.3

L	TS001	GA101	TI001
B	TS079	GA036	TI003
C	G501N		
E	G112		

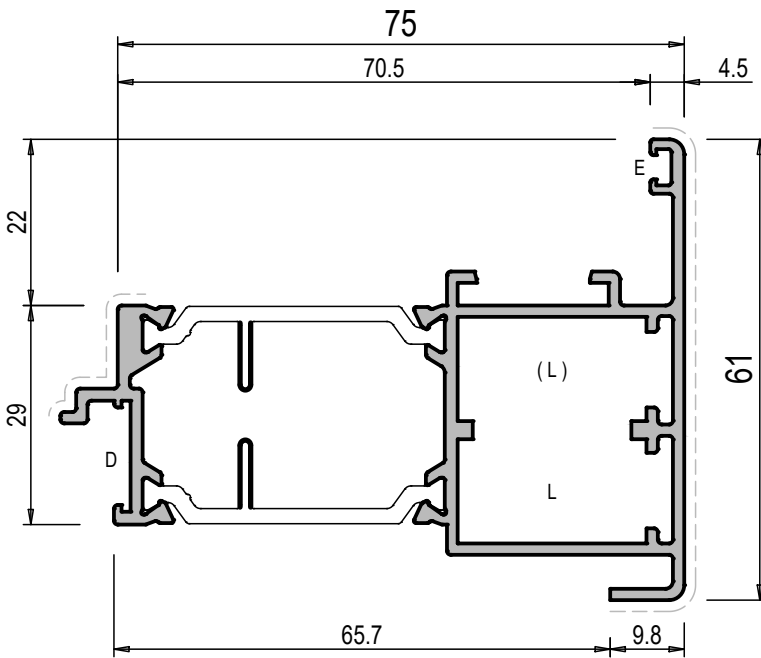

175019

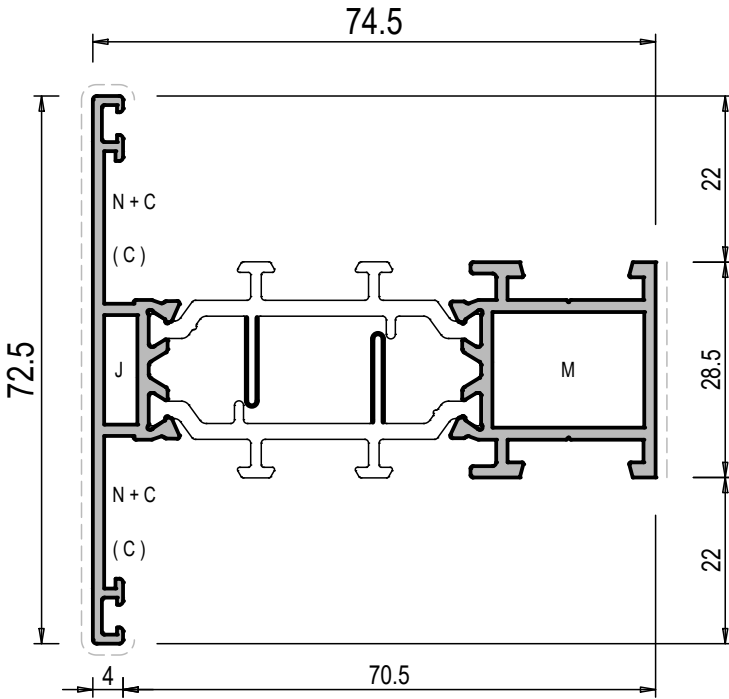

RIPORTO BILICO		Jx	8.4
PESO	1381	Jy	31.5
S. VISTA	98	Wx	2.8
		Wy	7

D	G269	GA101	TI001
E	G112		
L	TS002		



175020



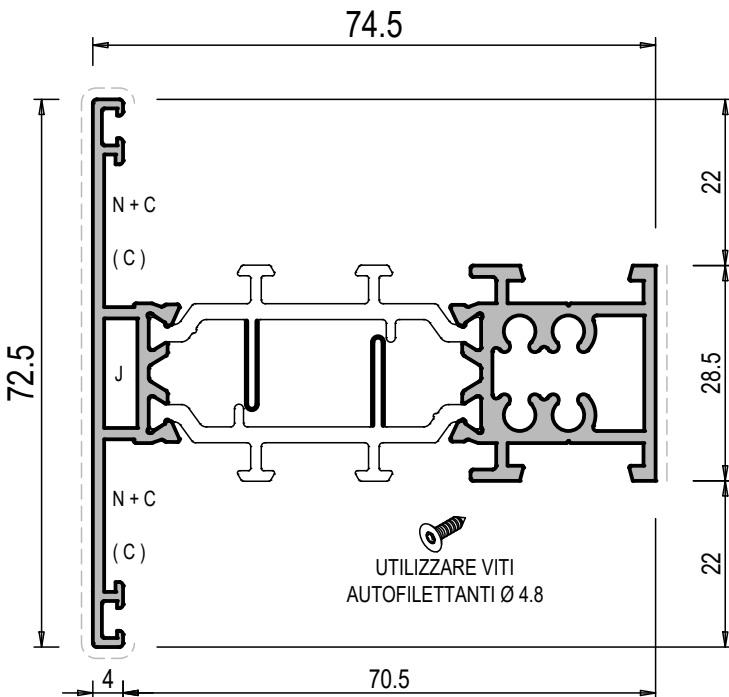

TRAVERSO CON CAVALLOTTI		Jx cm ⁴	7.0
PESO g/m	1338	Jy cm ⁴	27.3
S. VISTA mm	98	Wx cm ³	2.1
		Wy cm ³	6.3

C	 G501N	SU TELAIO		
M	 G199		GA101	TI002
N	 TS082	SU ANTA		
C	 G501N			
J	 TS073		GA112	



175021

TRAVERSO CON VITI		Jx cm ⁴	7.0
PESO g/m	1507	Jy cm ⁴	30.8
S. VISTA mm	98	Wx cm ³	2.1
		Wy cm ³	7.7

C	 G501N	SU TELAIO		
N	 TS082	SU ANTA		
C	 G501N			
J	 TS073		GA112	

TRAVERSI

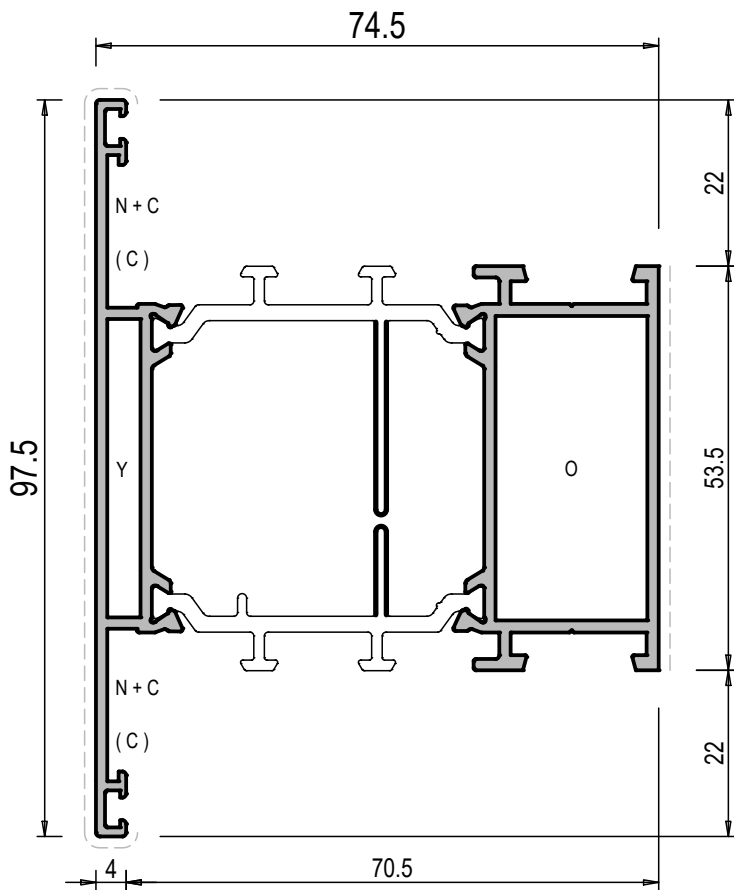

175022

TRAVERSO MAG.CON CAVALL.			Jx cm ⁴	26.6
PESO g/m	1756		Jy cm ⁴	37.1
S. VISTA mm	158		Wx cm ³	5.6
			Wy cm ³	9.1

C	G501N	SU TELAIO		
O	TS083		GA101	TI002
N	TS082	SU ANTA		
C	G501N			
Y	TS074		GA112	

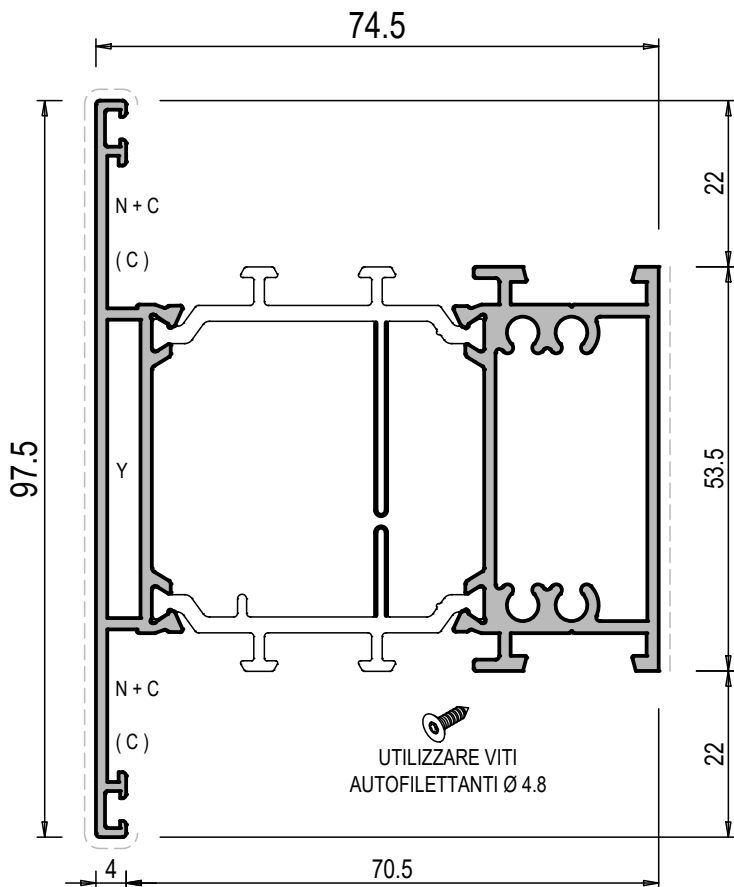

175023

TRAVERSO MAG.CON VITI			Jx cm ⁴	28.0
PESO g/m	1926		Jy cm ⁴	40.6
S. VISTA mm	158		Wx cm ³	5.6
			Wy cm ³	9.8

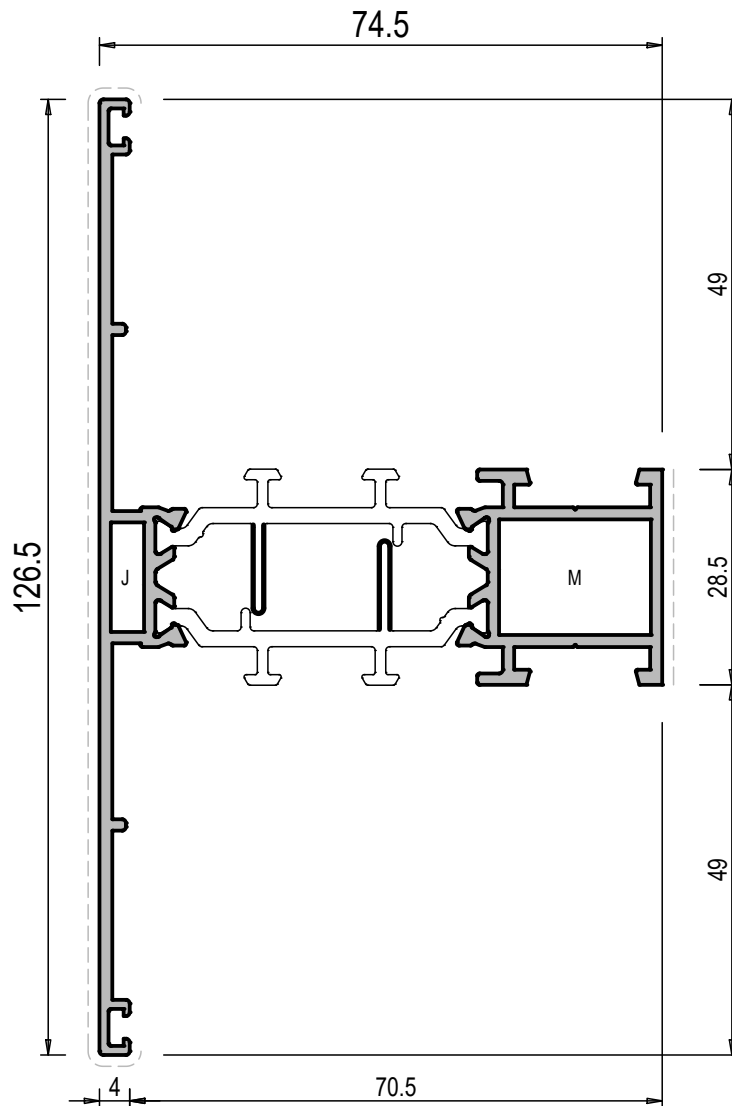

C	G501N	SU TELAIO		
N	TS082	SU ANTA		
C	G501N			
Y	TS074		GA112	

TRAVERSO/MONTANTE ANTA PIANA



175123

TRAVERSO ANTA A SCOMPARSA		Jx cm ⁴	25.2
PESO g/m	1615	Jy cm ⁴	33.6
S. VISTA mm	98	Wx cm ³	4.2
		Wy cm ³	7

M		G199		GA101	TI002
J		TS073		GA112	

Profilati Scala 1:1



ZOCCOLO RIPORTATO

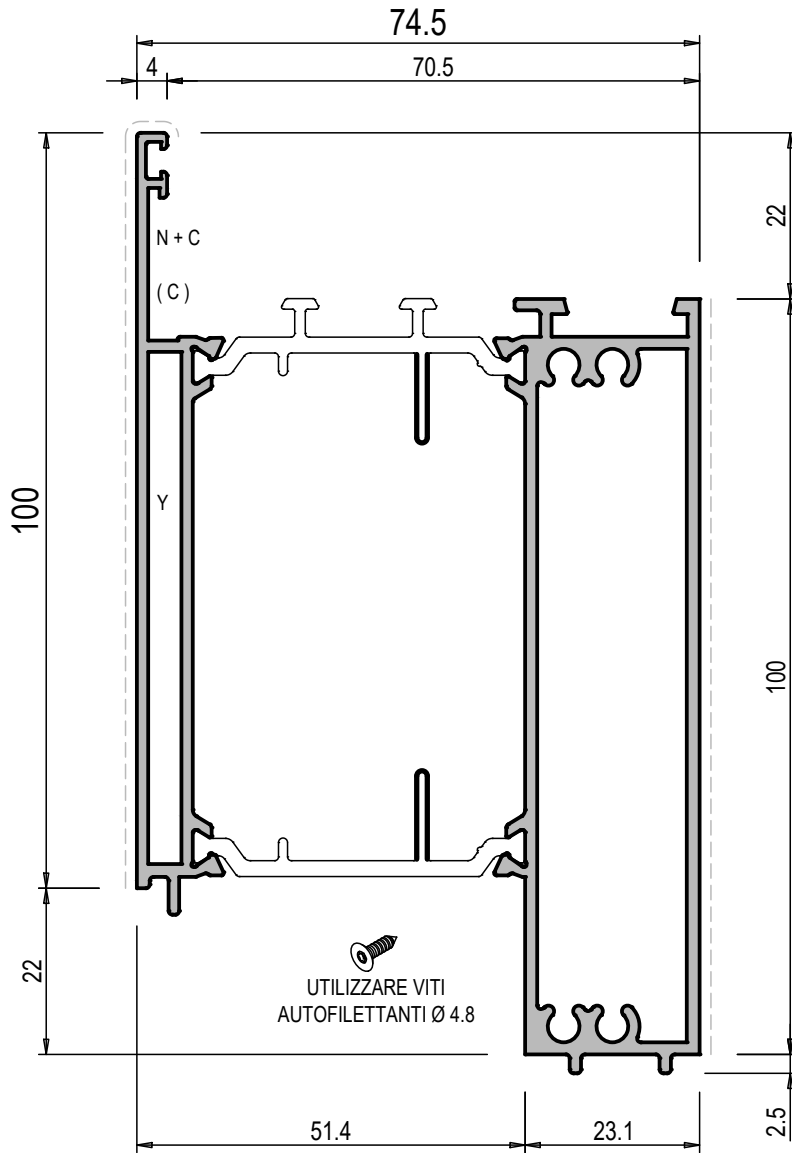

175024

ZOCCOLO RIPORTATO		Jx	86.1
PESO	2450	Jy	53.2
S. VISTA	204	Wx	14.0
		Wy	13.3
C	G501N	SU TELAIO	
N	TS082	SU ANTA	
C	G501N		
Y	TS074	GA112	

FASCIA

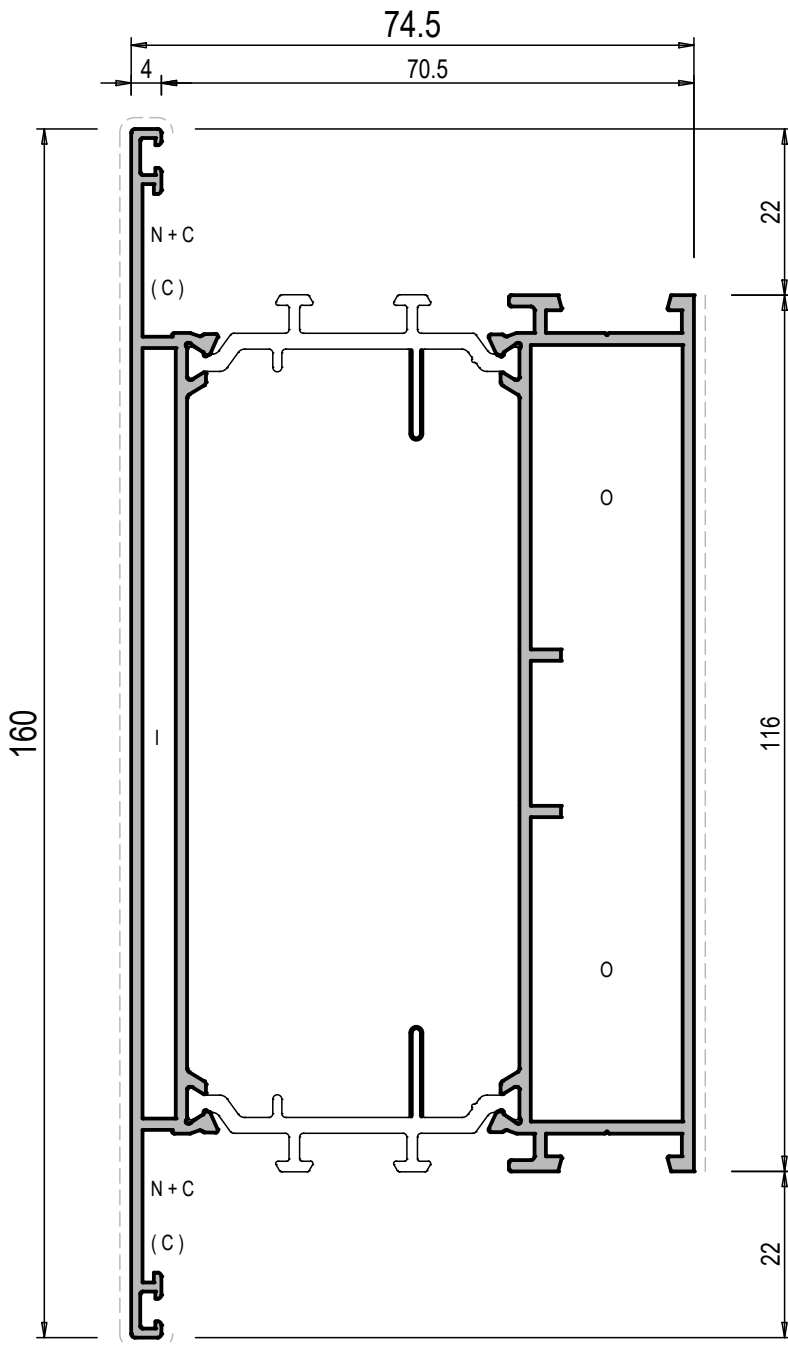

175025

FASCIA CON CAVALLOTTI		Jx	168.0
PESO	3005	Jy	67.2
S. VISTA	284	Wx	21.0
		Wy	18.9

C	G501N	SU TELAIO		
O	TS083		GA101	TI002
N	TS082	SU ANTA		
C	G501N			
Y	TS088		GA112	

FASCIA

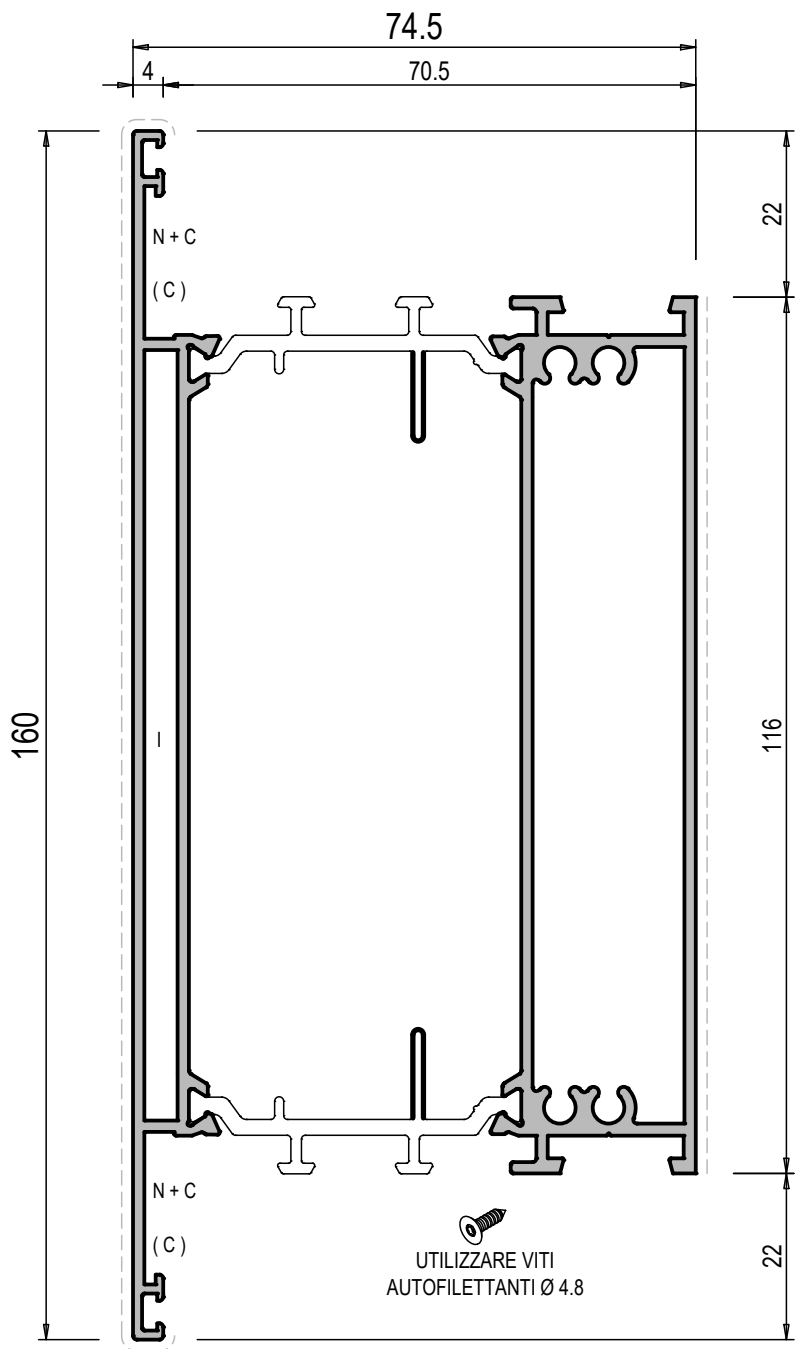

175026

FASCIA CON VITI		Jx	175.0
PESO	3031	Jy	66.5
S. VISTA	284	Wx	21.7
		Wy	16.1

C	G501N	SU TELAIO		
N	TS082	SU ANTA		
C	G501N			
I	TS088	GA112		

ZOCCOLO

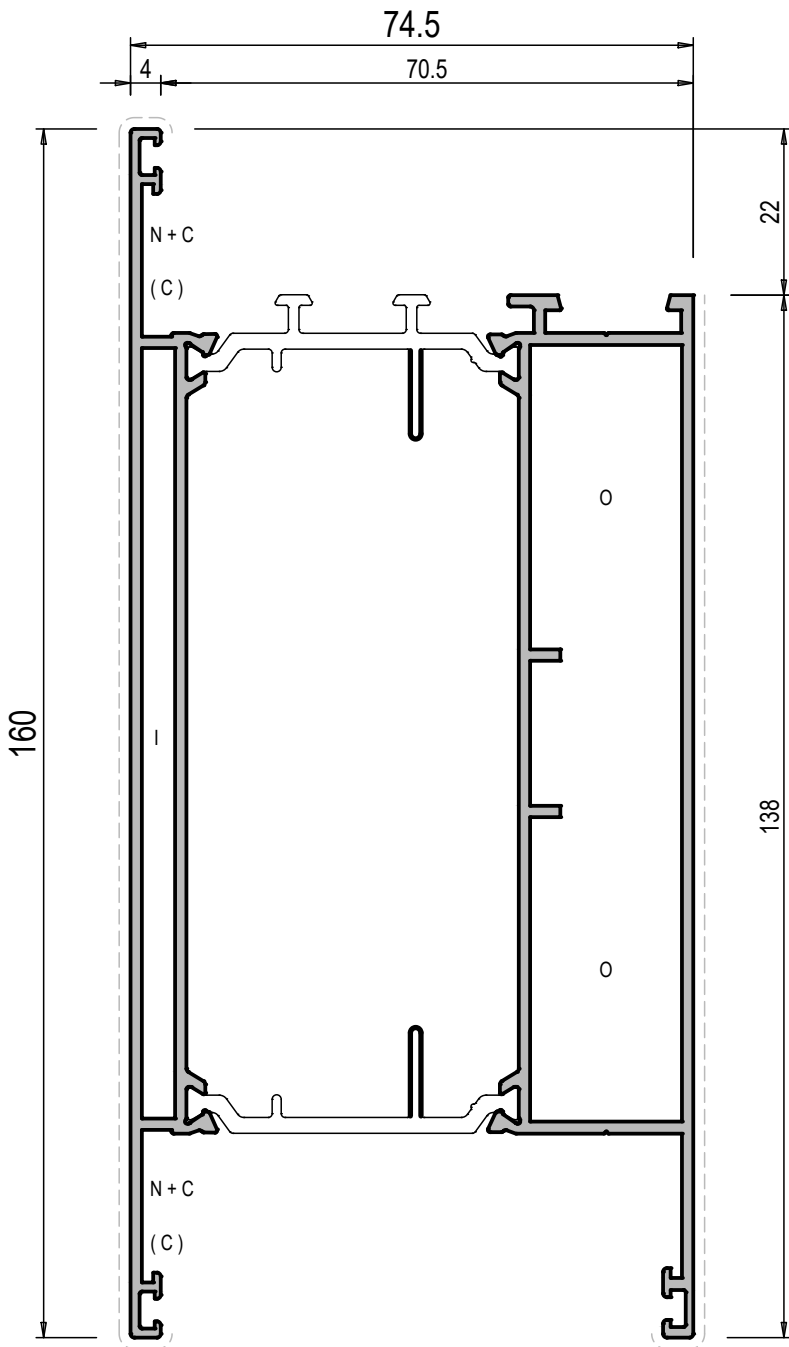

175027

ZOCCOLO CON CAVALLOTTI		Jx	172.2
PESO	3013	Jy	70.7
S. VISTA	314	Wx	21.7
		Wy	17.5

C	G501N	SU TELAIO		
O	TS083		GA101	TI002
N	TS082	SU ANTA		
C	G501N			
I	TS088		GA112	

ZOCCOLO

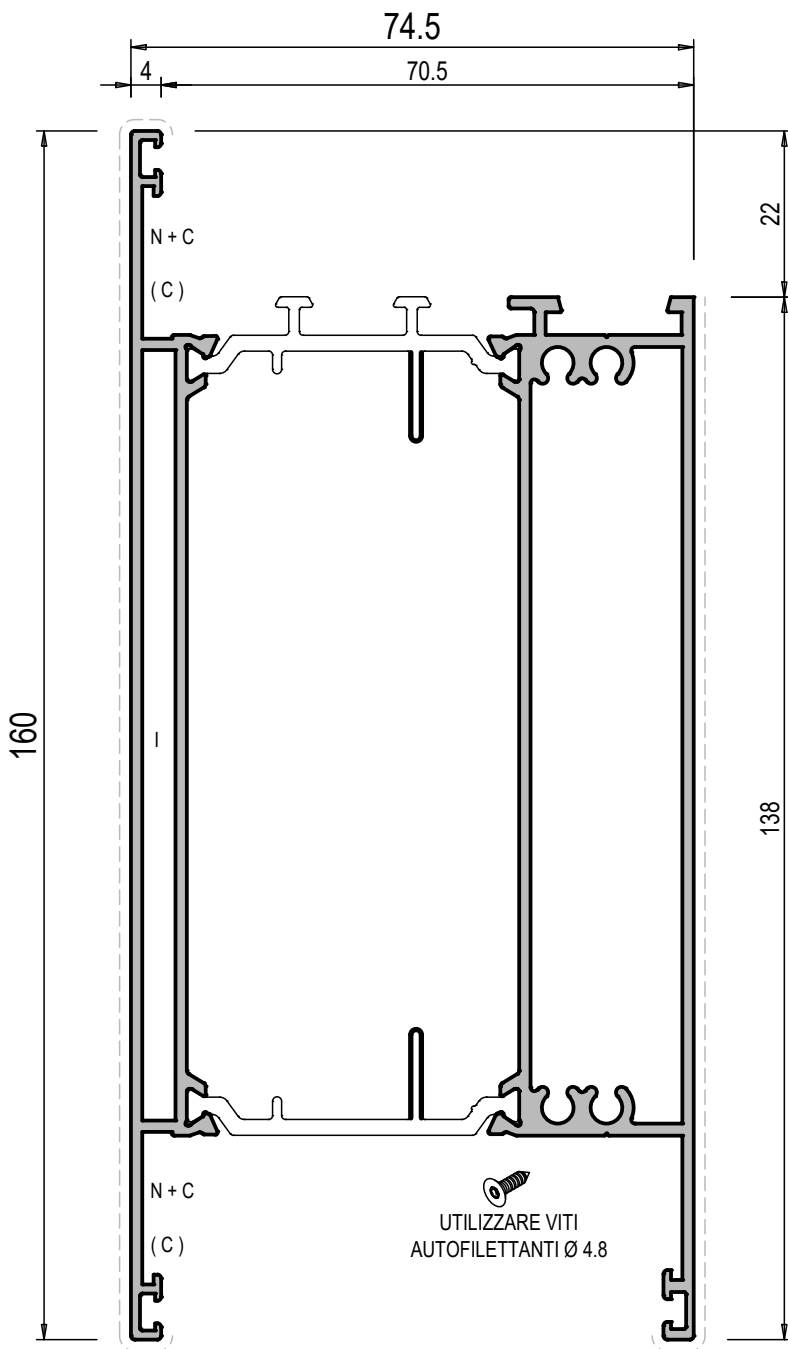

175028

ZOCCOLO CON VITI		Jx	180.6
PESO	3117	Jy	72.1
S. VISTA	314	Wx	22.4
		Wy	18.2

C	G501N	SU TELAIO		
C	TS082	SU ANTA		
C	G501N			
I	TS088		GA112	

TRAVERSI ANTA PIANA

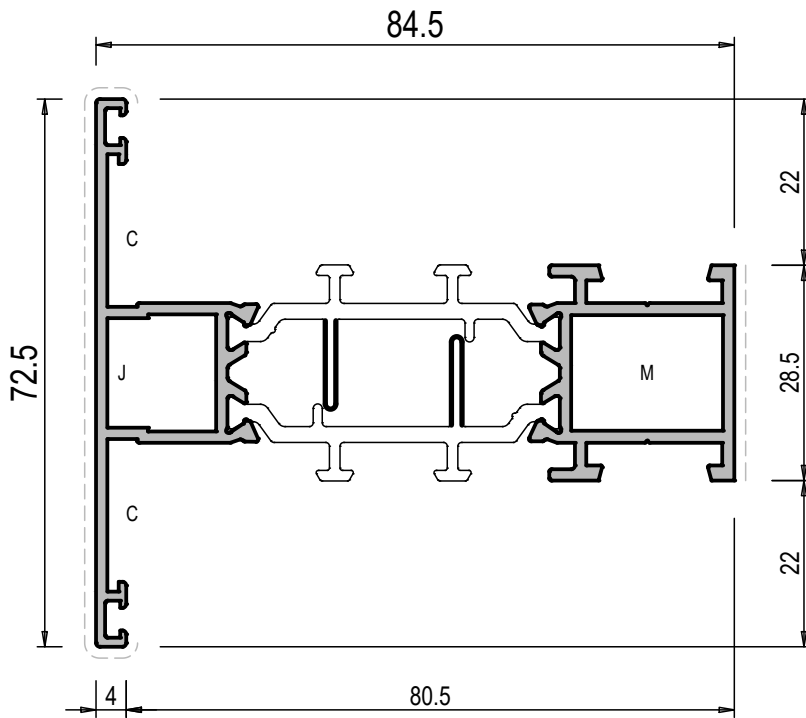

175041

TRAVERSO PER ANTA PIANA CON CAVALLOTTI		Jx cm ⁴	7.0
PESO g/m	1422	Jy cm ⁴	25.7
S. VISTA mm	108	Wx cm ³	2.1
		Wy cm ³	7.7

C	G501N	SU TELAIO		
M	G199		GA101	TI002
J	TS073		GA112	

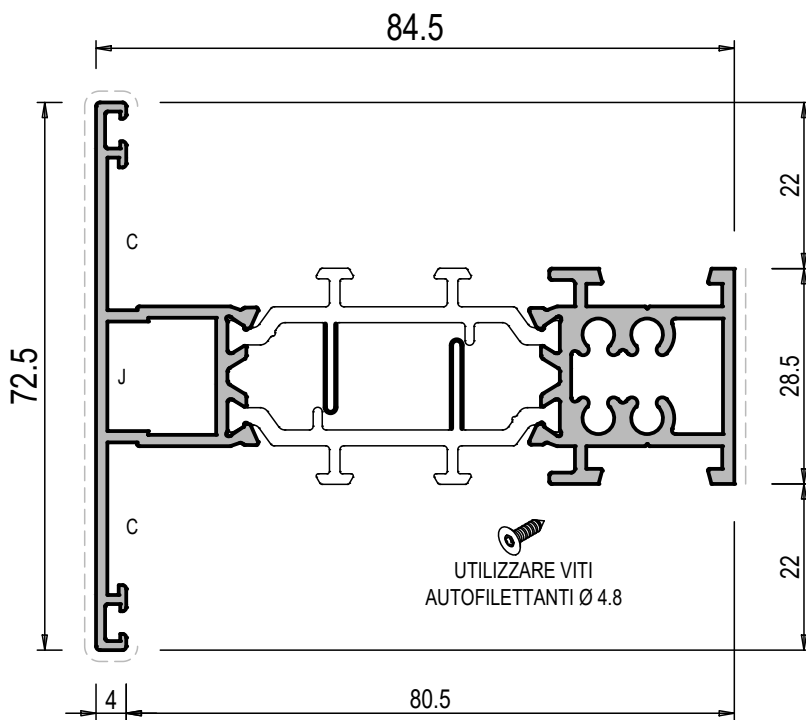

175052

TRAVERSO PER ANTA PIANA CON VITI		Jx cm ⁴	7.0
PESO g/m	1591	Jy cm ⁴	39.9
S. VISTA mm	108	Wx cm ³	2.1
		Wy cm ³	9.1

C	G501N	SU TELAIO		
J	TS073			
Y	TS074		GA112	

Profilati Scala 1:1



TRAVERSI ANTA PIANA

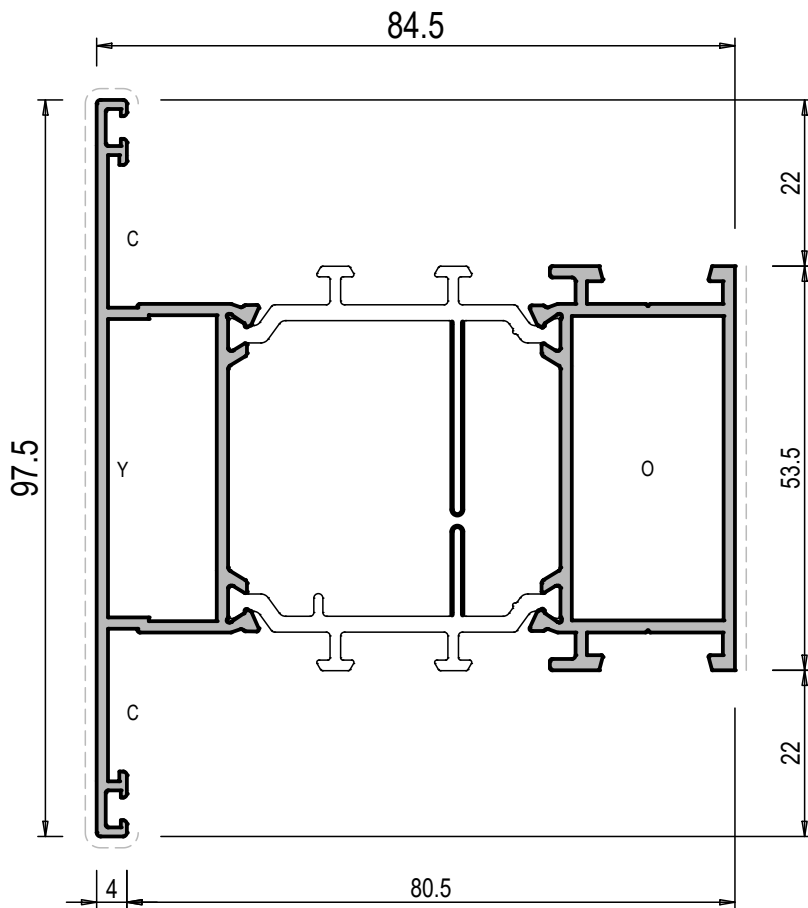

175042

TRAVERSO PER ANTA PIANA CON CAVALLOTTI		Jx cm ⁴	27.3
PESO g/m	1840	Jy cm ⁴	47.6
S. VISTA mm	158	Wx cm ³	5.6
		Wy cm ³	10.5

C	G501N			
O	TS083		GA101	TI002
Y	TS074		GA112	

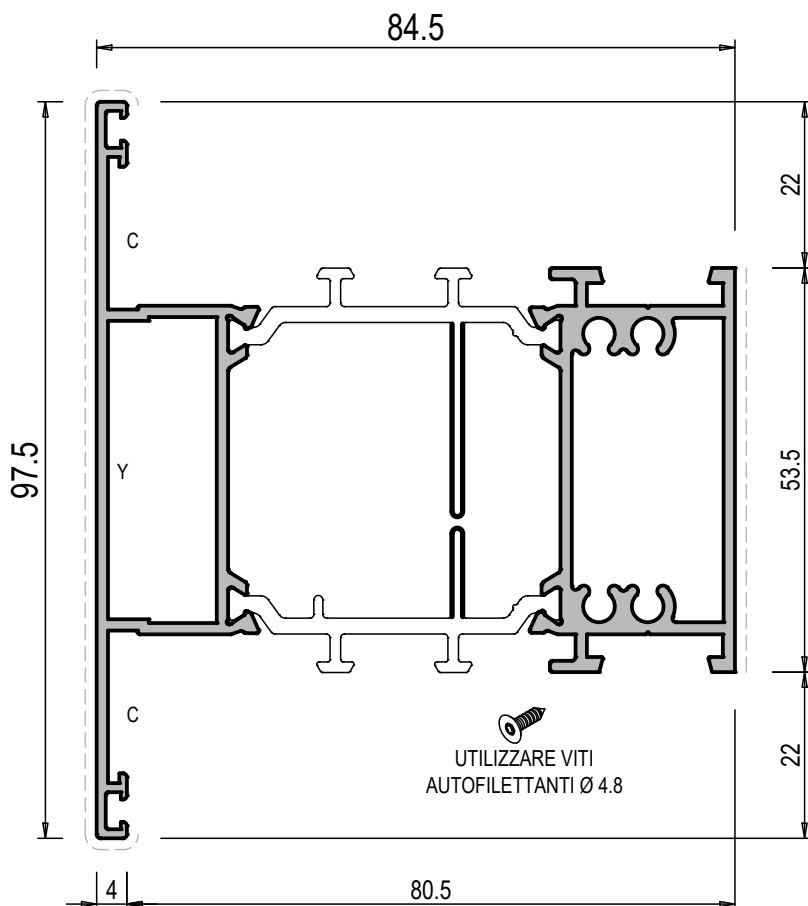

175053

TRAVERSO PER ANTA PIANA CON VITI		Jx cm ⁴	28.7
PESO g/m	2010	Jy cm ⁴	51.8
S. VISTA mm	158	Wx cm ³	5.6
		Wy cm ³	11.9

C	G501N			
Y	TS074		GA112	

ZOCCOLO RIPORTATO ANTA PIANA

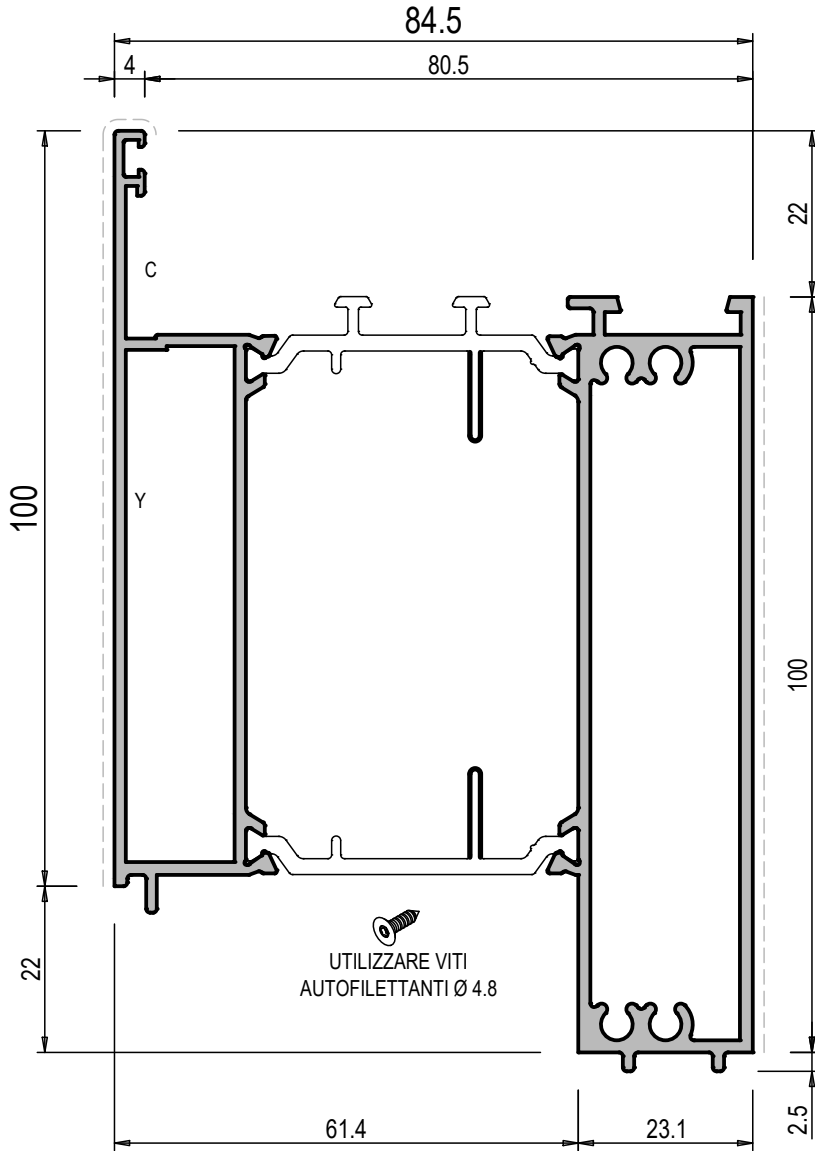

175043

ZOCCOLO RIP. PER ANTA PIANA		Jx	88.9
PESO	2556	Jy	67.2
S. VISTA	204	Wx	14.0
		Wy	15.4
C	G501N		
Y	TS074	GA112	

FASCIA ANTA PIANA

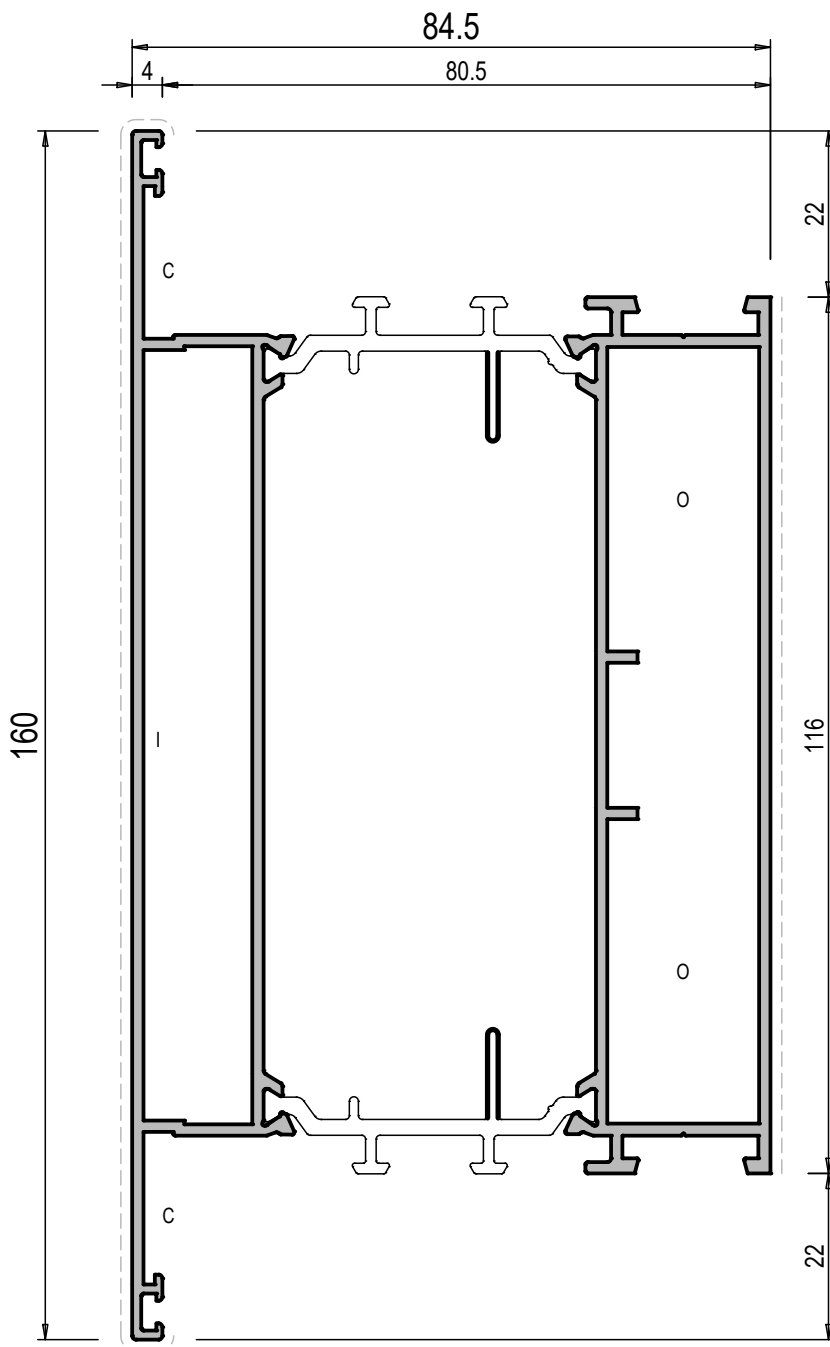

175044

FASCIA PER ANTA PIANA CON CAVALLOTTI		Jx	173.6
PESO	3065	Jy	83.3
S. VISTA	284	Wx	21.7
		Wy	18.9
C	G501N		
O	TS083	GA101	TI002
I	TS088	GA112	

FASCIA ANTA PIANA

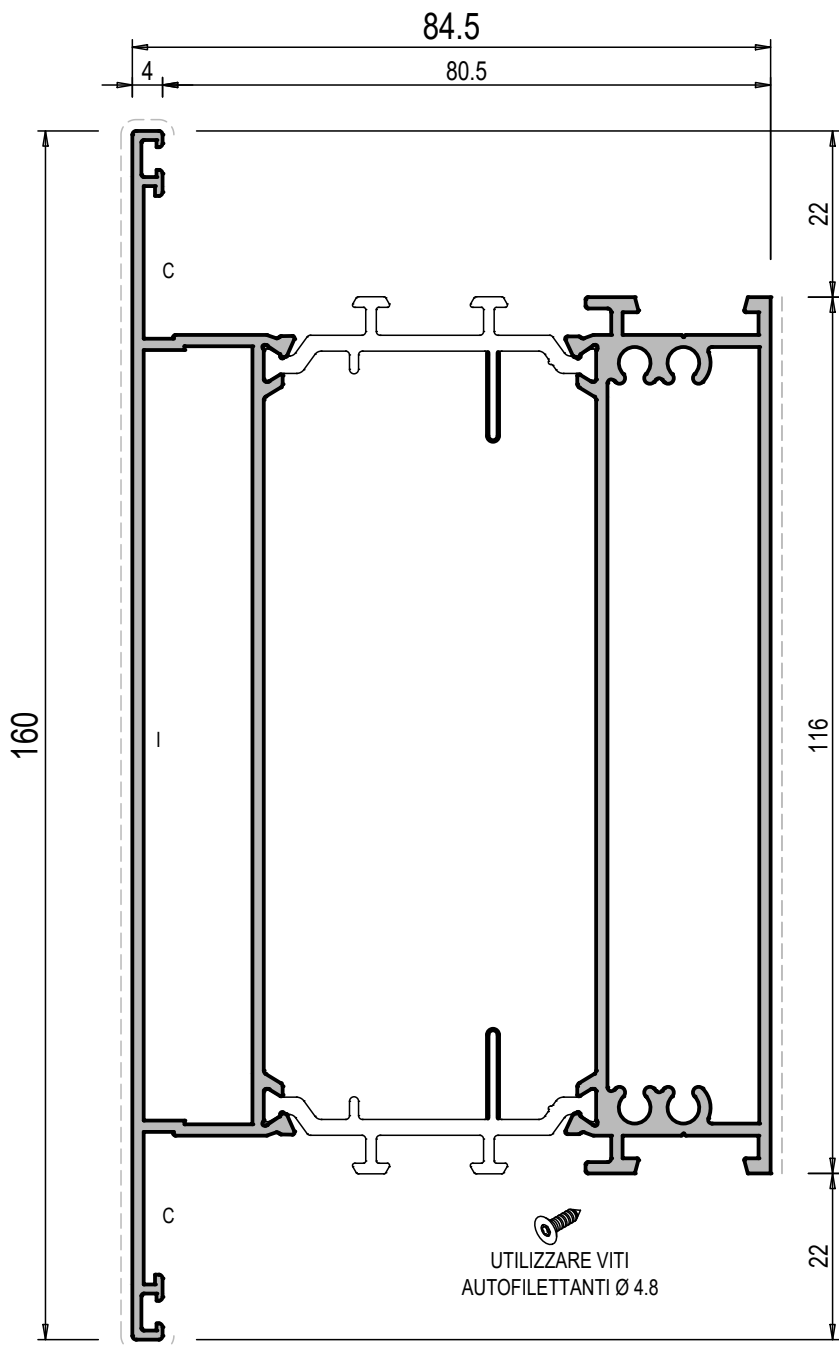

175054

FASCIA PER ANTA PIANA CON VITI		Jx	181.3
PESO g/m	3091	Jy	83.3
S. VISTA mm	284	Wx	26.6
		Wy	18.9
C	G501N		
I	TS088	GA112	

UTILIZZARE VITI
AUTOFILETTANTI Ø 4.8

ZOCCOLO ANTA PIANA

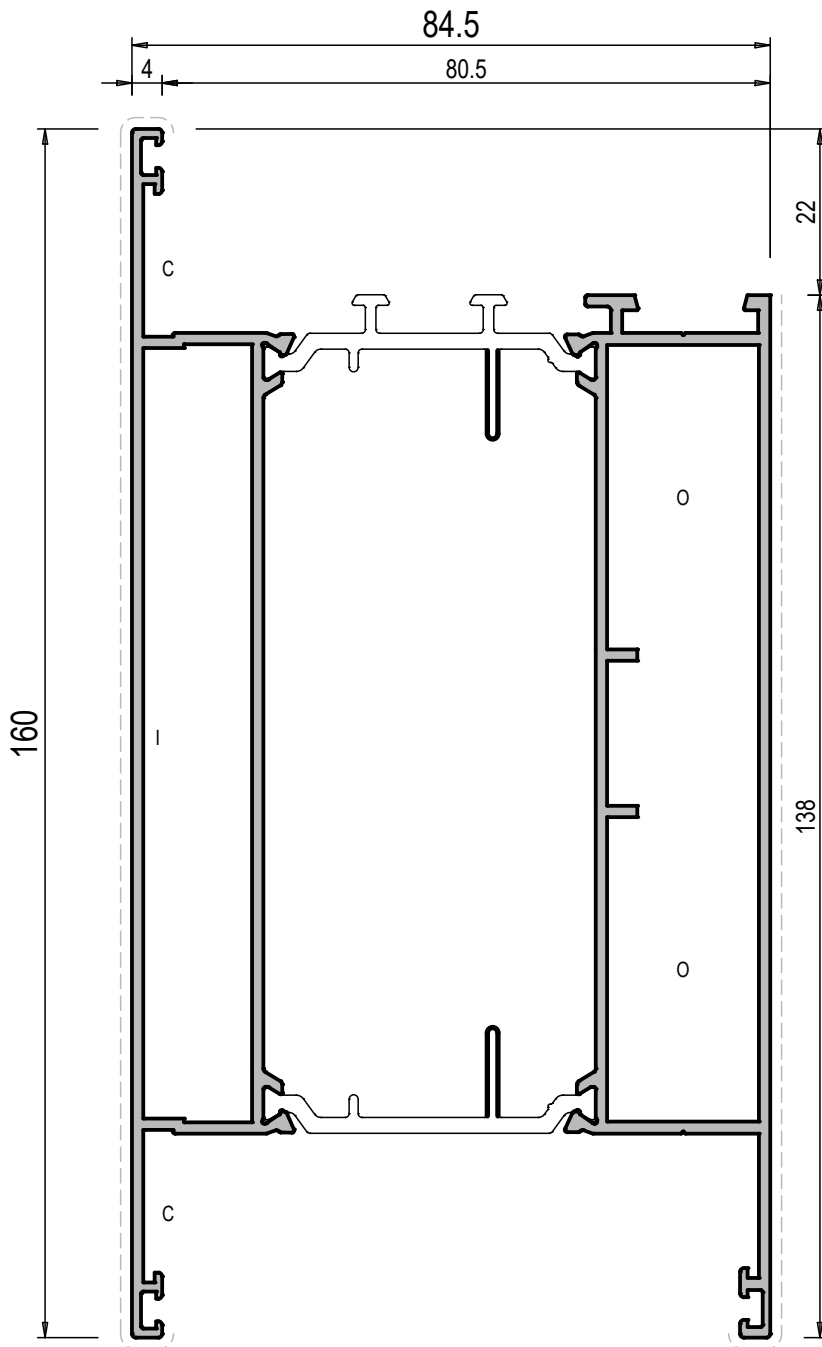

175045

ZOCCOLO PER ANTA PIANA CON CAVALLOTTI		Jx	177.8
PESO	3073	Jy	87.5
S. VISTA	310	Wx	22.4
		Wy	27.3
C	G501N		
O	TS083	GA101	TI002
I	TS088	GA112	

ZOCCOLO ANTA PIANA

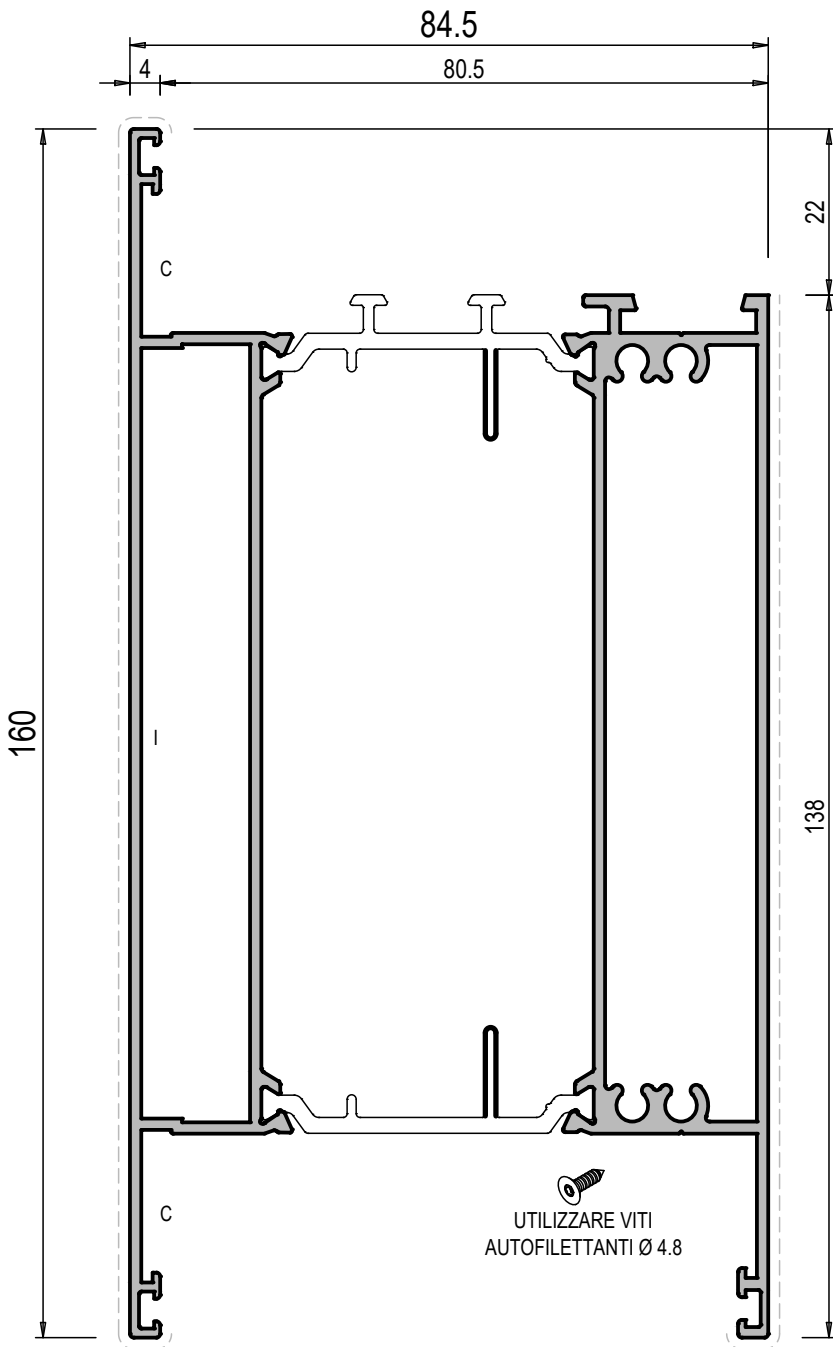

175055

ZOCCOLO PER ANTA PIANA CON VITI		Jx	186.9
PESO g/m	3177	Jy	90.3
S. VISTA mm	310	Wx	23.1
		Wy	21.0
C	G501N		
I	TS088	GA112	

UTILIZZARE VITI
AUTOFILETTANTI Ø 4.8

PILASTRINI

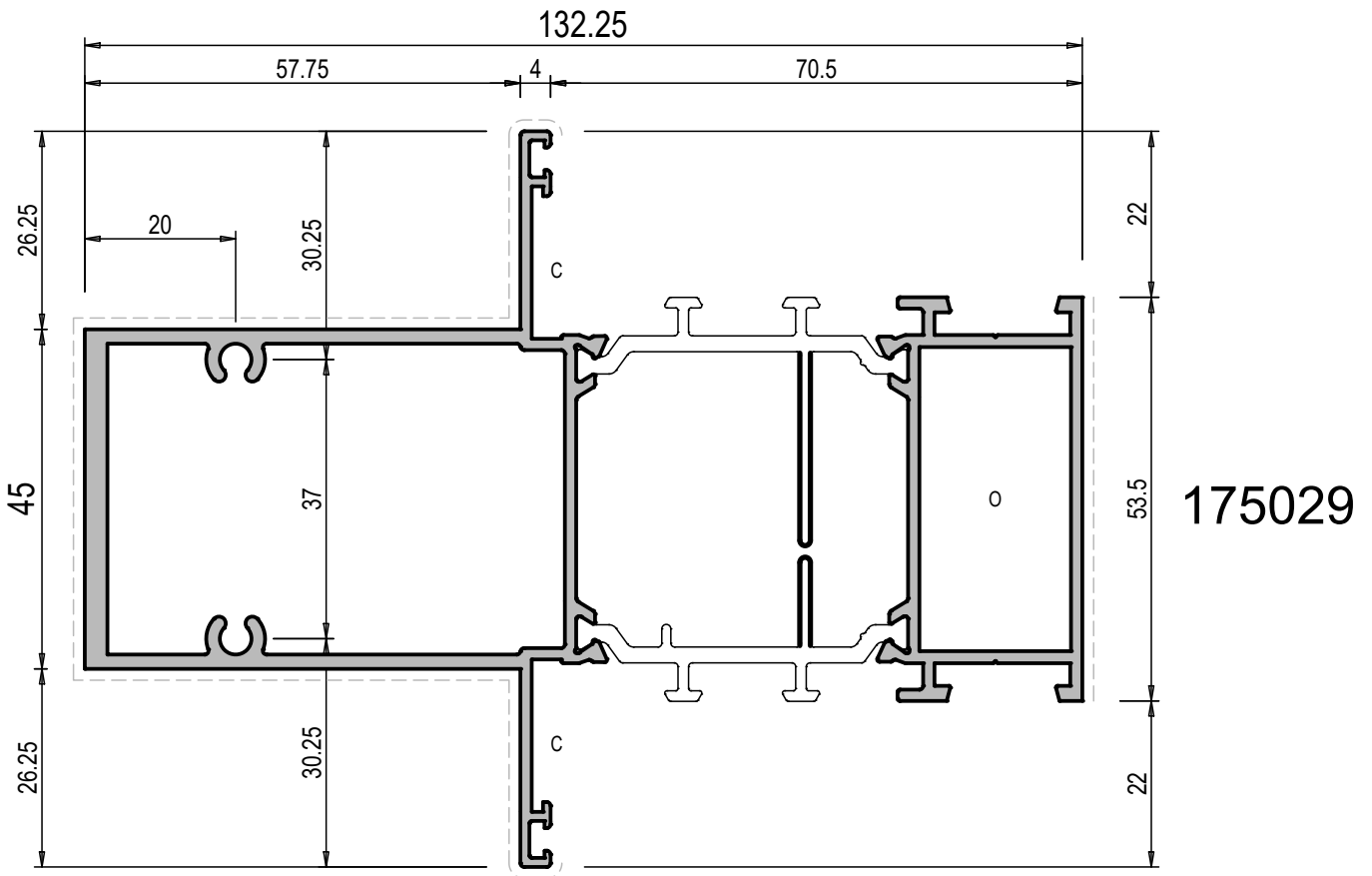

PILASTRINO			Jx cm ⁴	35.7	O	TS083		GA101	
PESO g/m	2649		Jy cm ⁴	137.9	C	G501N			TI002
S. VISTA mm	274		Wx cm ³	7.0					
			Wy cm ³	20.3					

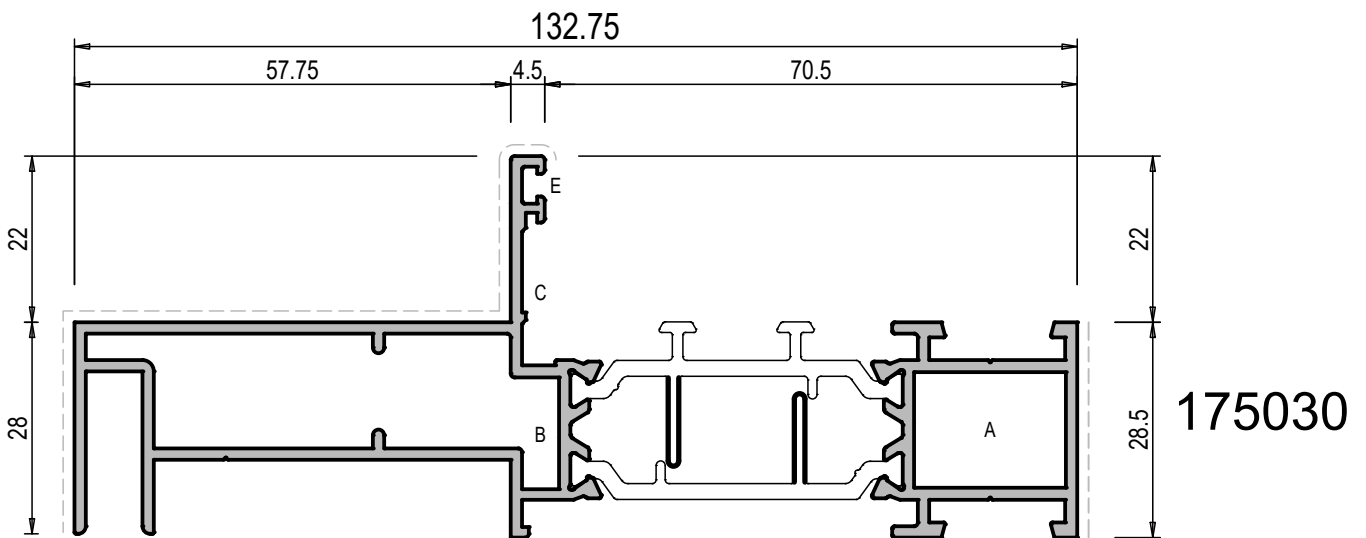

SCARICO ACQUA NON ESEGUIBILE CON PUNZONATRICI.

SEMIPILASTRINO			Jx cm ⁴	6.3	A	TS078	TS077	GA101	TI001
PESO g/m	1885		Jy cm ⁴	92.4	B	TS079		GA036	TI003
S. VISTA mm	140		Wx cm ³	2.1	C	G501N			
			Wy cm ³	12.6	E	G112			

PROFILATI COMPLEMENTARI

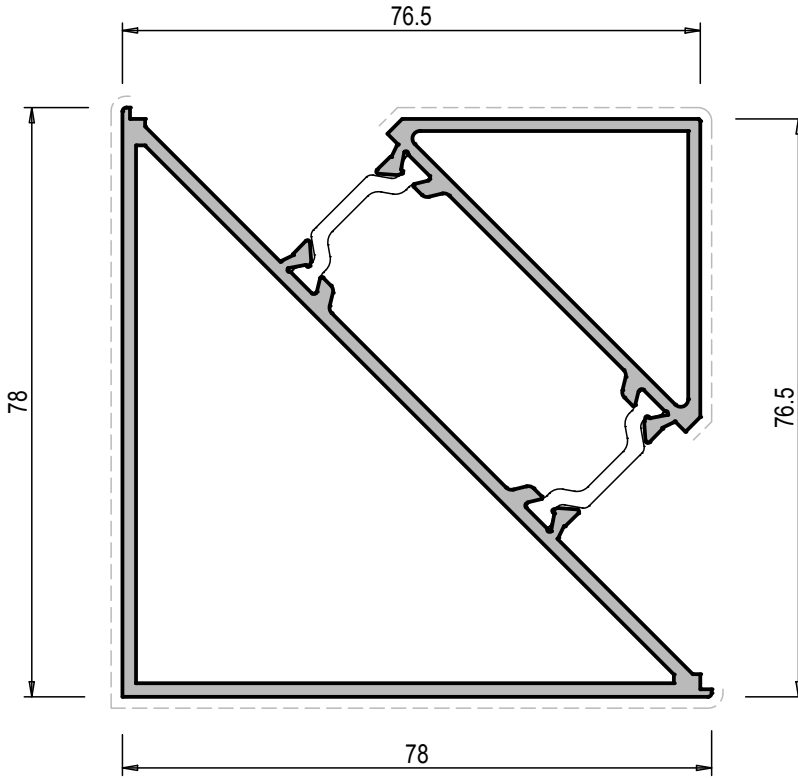

61727

GIUNZIONE 90°			Jx cm ⁴	38.9		
PESO g/m	2129		Jy cm ⁴	38.9		
S. VISTA mm	241		Wx cm ³	9.7		
			Wy cm ³	9.7		

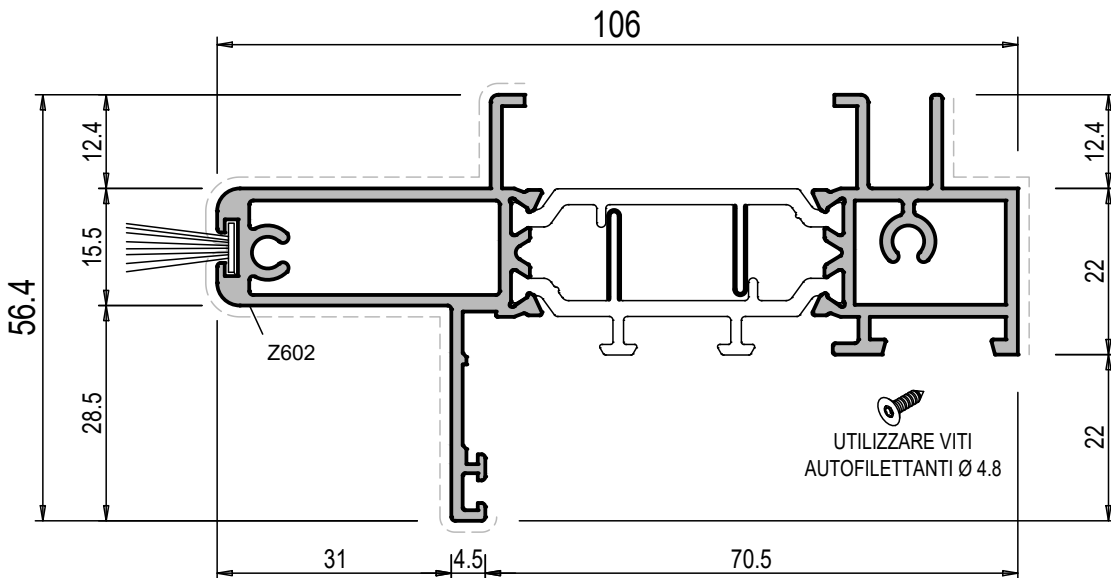

175031

CIELINO MONOBLOCCO			Jx cm ⁴	5.6		
PESO g/m	1707		Jy cm ⁴	51.1		
S. VISTA mm	170		Wx cm ³	1.4		
			Wy cm ³	9.1		

Profilati Scala 1:1



SPALLA MONOBLOCCO

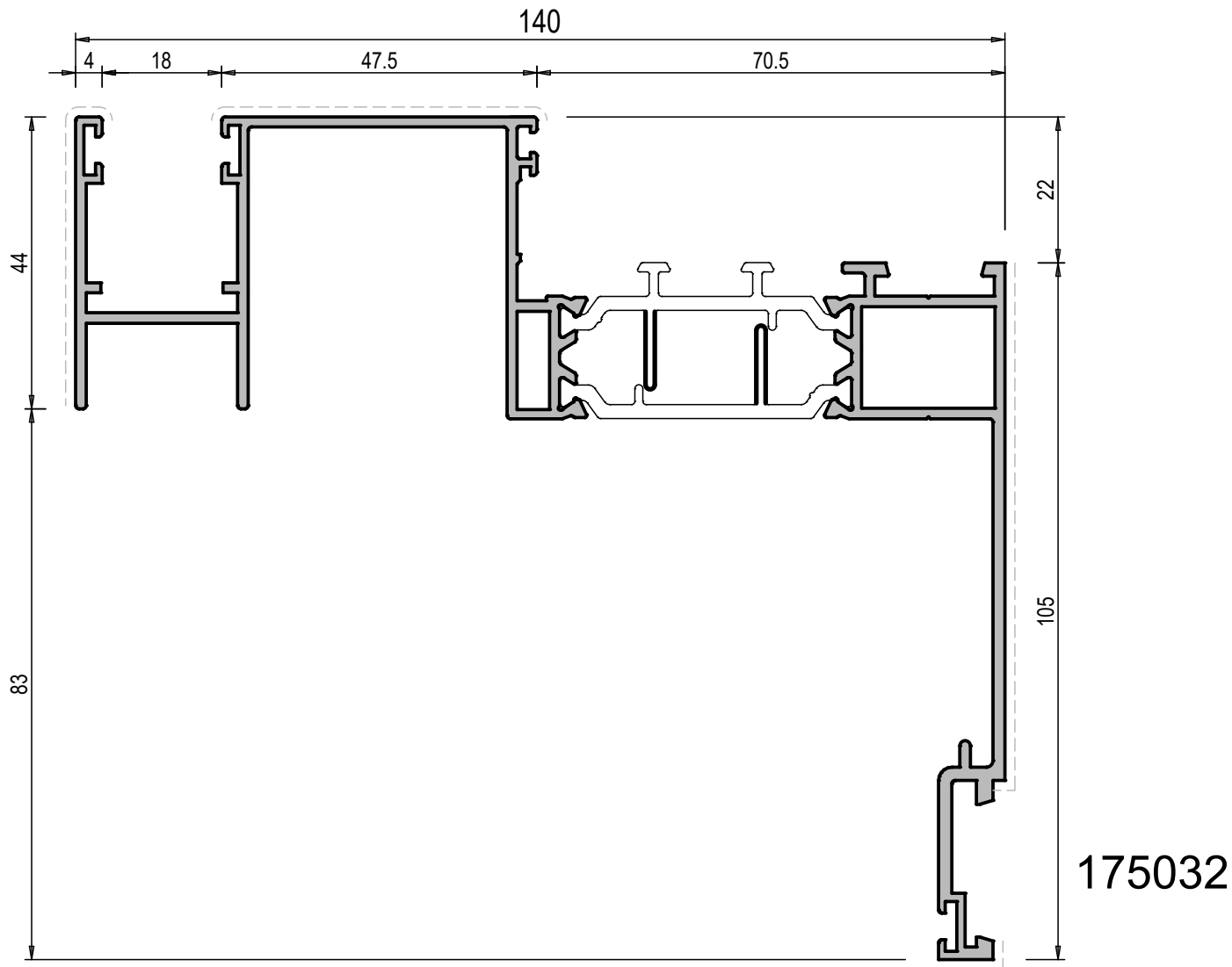

SPALLA MONOBLOCCO			Jx	64.4		
PESO	2406		Jy	147.7		
S. VISTA	174		Wx	7.7		
			Wy	17.5		

1234

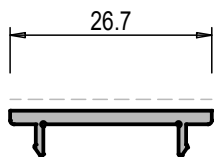

COMPLEMENTARE MONOB.			Jx	
PESO	151		Jy <td></td>	
S. VISTA	27		Wx <td></td>	
			Wy <td></td>	

SPALLA MONOBLOCCO

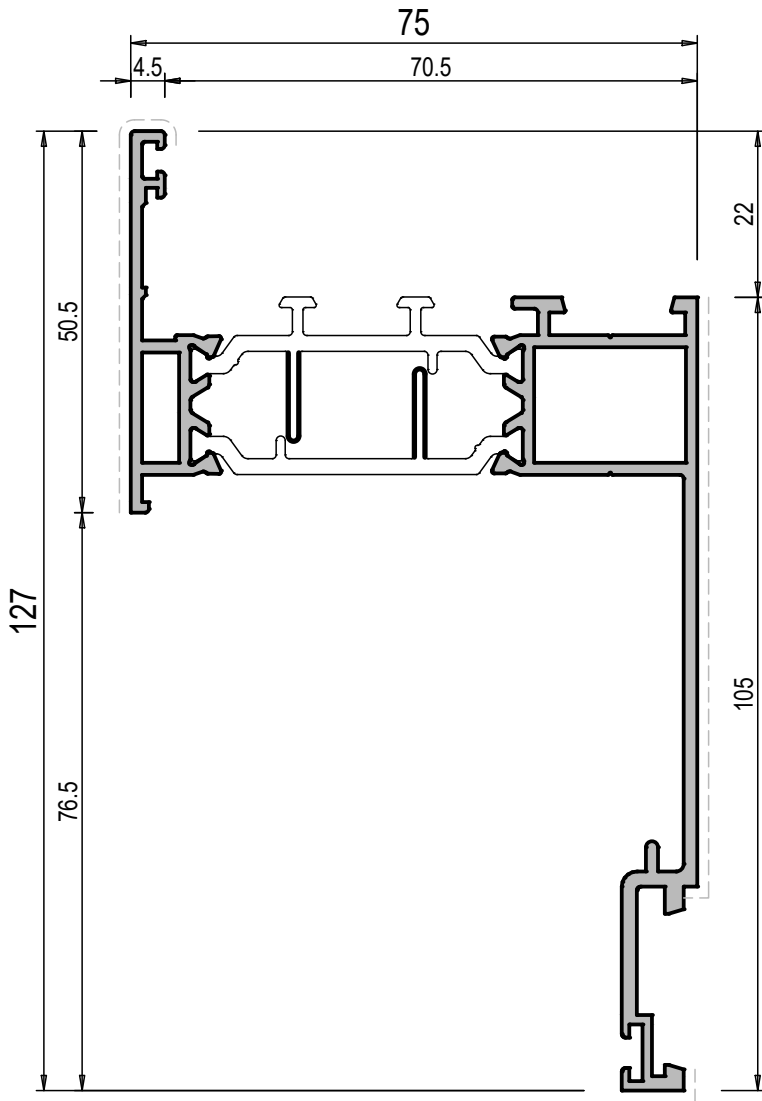

175078

SPALLA MONOBLOCCO			Jx	47.6
PESO	1686		Jy	39.9
S. VISTA	130	Wx	6.3	
		Wy	9.8	

CASSONOTTO

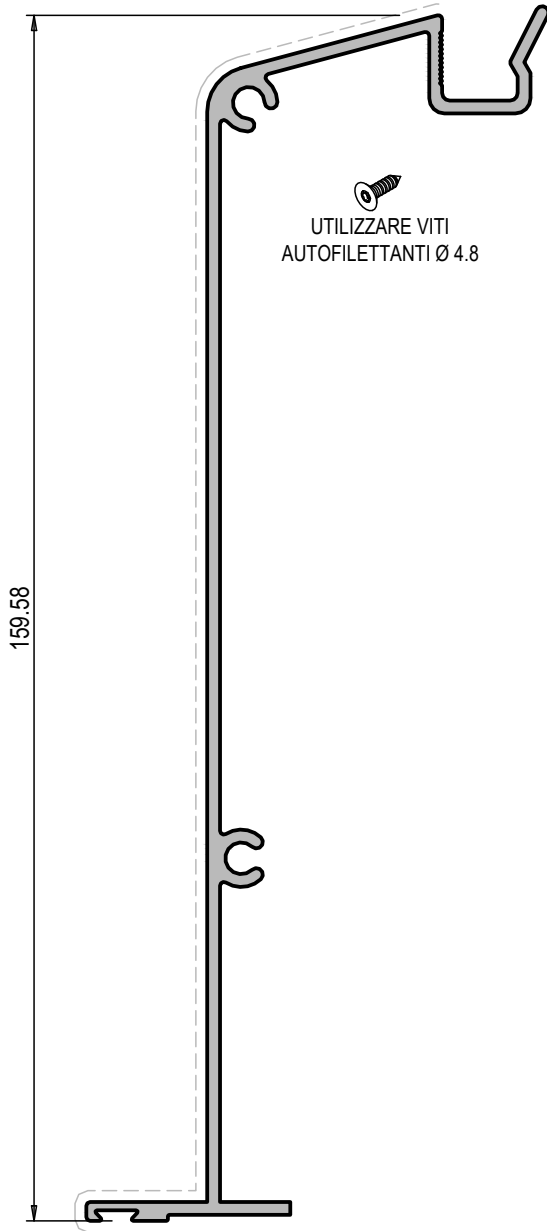

UTILIZZARE VITI
AUTOFILETTANTI Ø 4.8

159.58

1185

CASSONETTO "A"			Jx	cm ⁴	
PESO	1250		Jy	cm ⁴	
S. VISTA	196		Wx	cm ³	
mm			Wy	cm ³	

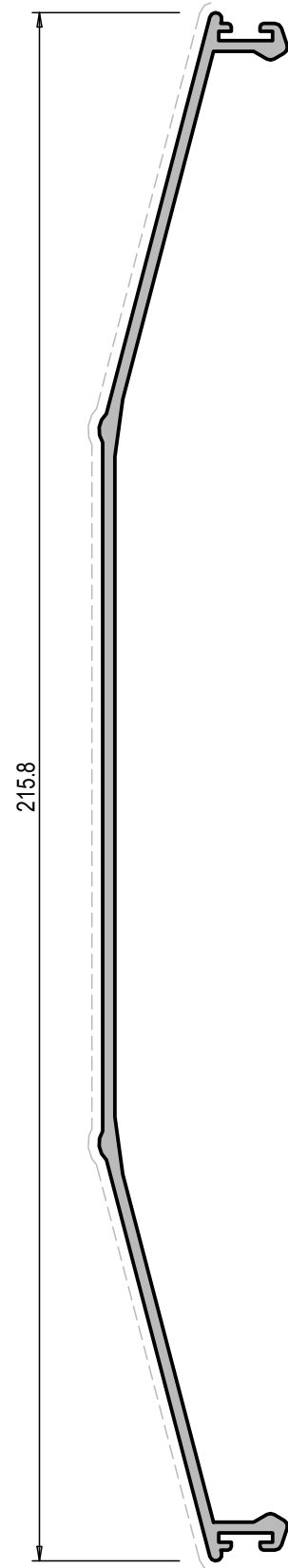

215.8

1184

CASSONETTO "B"			Jx	cm ⁴	
PESO	1165		Jy	cm ⁴	
S. VISTA	220		Wx	cm ³	
mm			Wy	cm ³	

TELAIO CAPANNONI

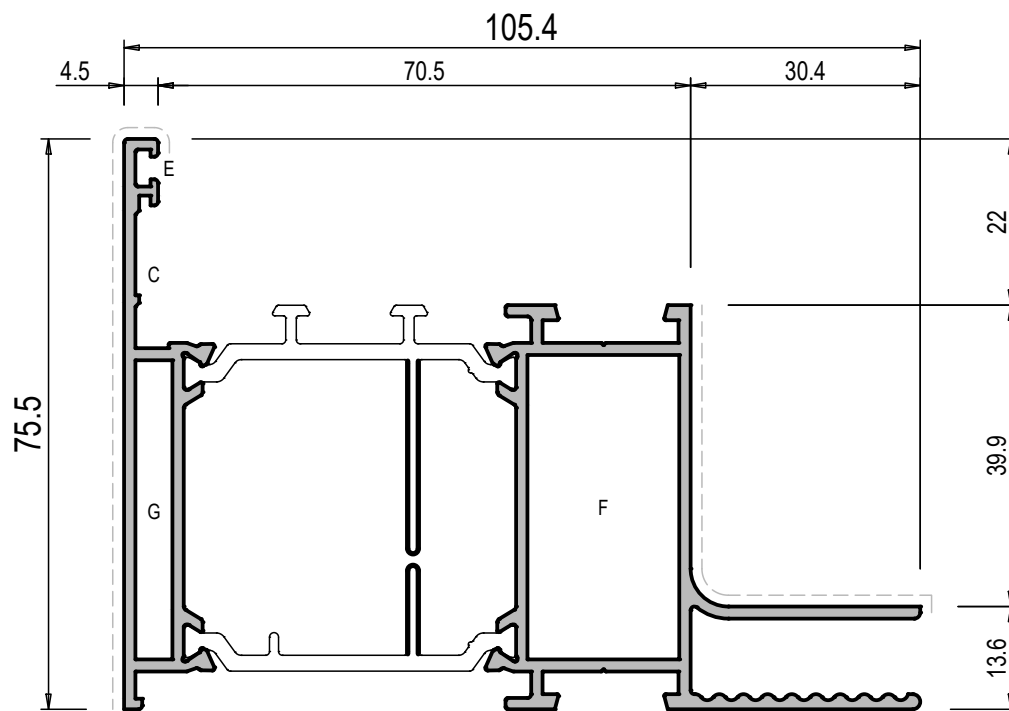

175124

TELAIO L CAPANNONI		Jx	28
PESO	2187	Jy	74.9
S. VISTA	151	Wx	5.6
		Wy	10.5

C	G501N				
E	G112				
F	TS080			GA101	TI001
G	TS081				TI003

Profilati Scala 1:1



TELAIO CAPANNONI

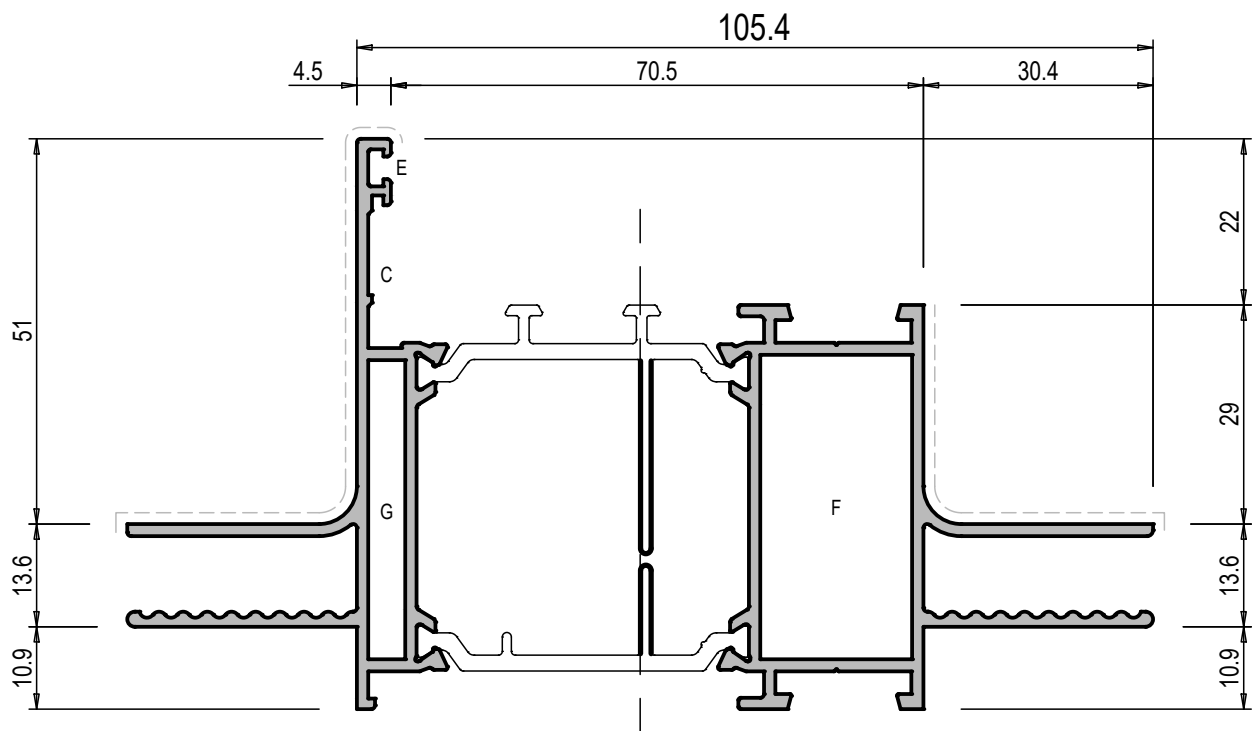

175035

TELAIO L CAPANNONI		Jx cm ⁴	23.8
PESO g/m	2187		
S. VISTA mm	142	Wx cm ³	4.9
		Wy cm ³	10.5

C		G501N				
D		G269				
E		G112				
F		TS080				T1001
G		TS081				T1003

TELAIO CAPANNONI

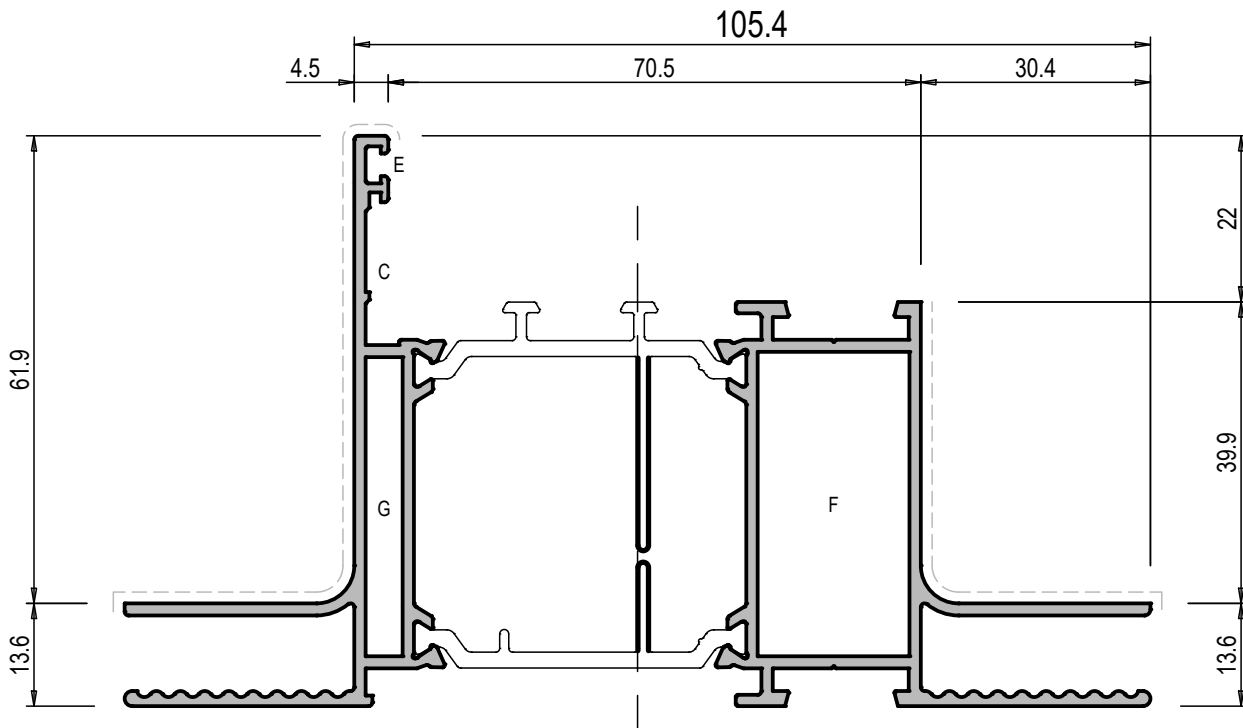

175092

TELAIO L CAPANNONI		Jx	28.0
PESO	2173	Jy	74.9
S. VISTA	164	Wx	5.6
		Wy	10.5
C	G501N		
D	G269		
E	G112		
F	TS080		T1001
G	TS081		T1003

Profilati Scala 1:1



IMBOTTE CAPANNONI

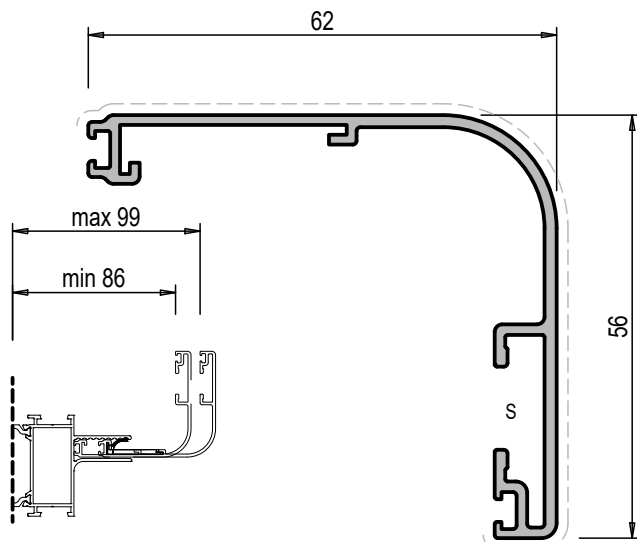

40291

IMBOTTE "A"		Jx	cm ⁴	
PESO	641	Jy	cm ⁴	
S. VISTA	120	Wx	cm ³	
S	TA1000	Wy	cm ³	

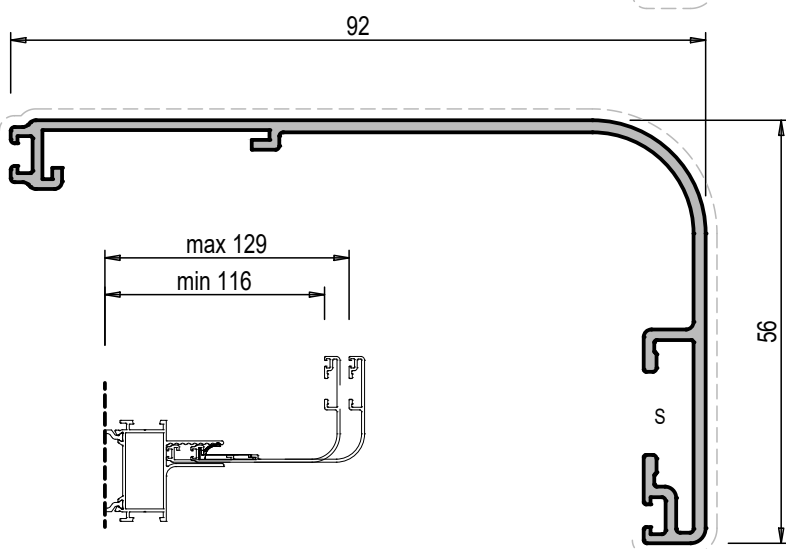

40292

IMBOTTE "B"		Jx	cm ⁴	
PESO	770	Jy	cm ⁴	
S. VISTA	150	Wx	cm ³	
S	TA1000	Wy	cm ³	

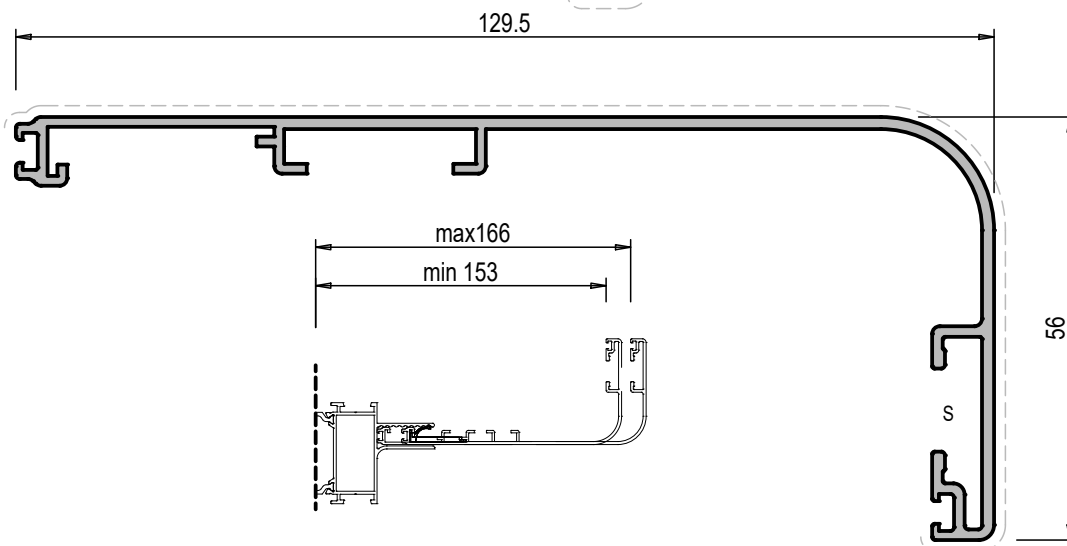

40293

IMBOTTE "C"		Jx	cm ⁴		S	TA1000	
PESO	985	Jy	cm ⁴				
S. VISTA	188	Wx	cm ³				
		Wy	cm ³				

PILASTRINO UNIVERSALE

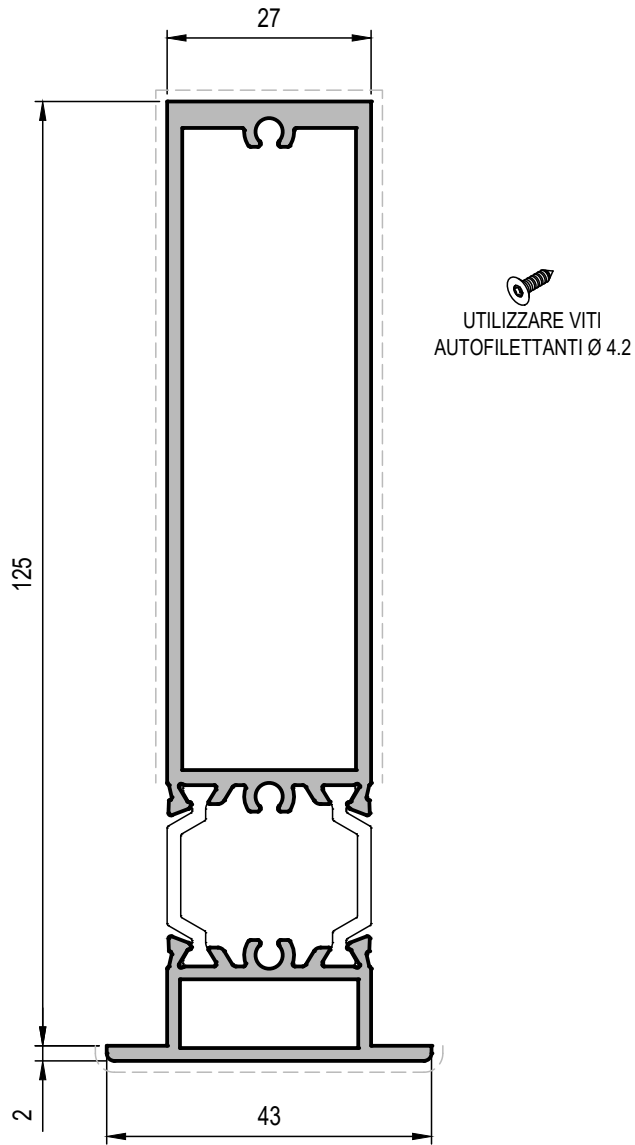

55590

PILASTRINO UNIVERSALE			Jx	11.8		
PESO g/m	2089		Jy	4.6		
S. VISTA mm	255	Wx	3.4			
		Wy	1.4			

Profilati Scala 1:1



PROFILATI COMPLEMENTARI

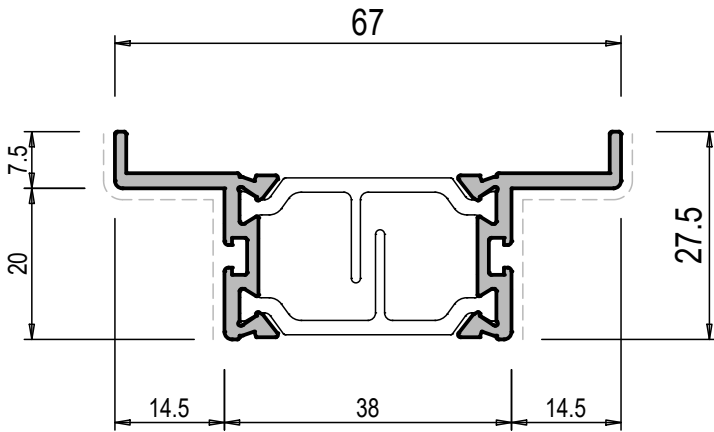

175080

GIUNZIONE TELAI IN FACCIATA			Jx	cm ⁴
PESO	796		Jy	cm ⁴
S. VISTA	84	Wx	cm ³	
		Wy	cm ³	

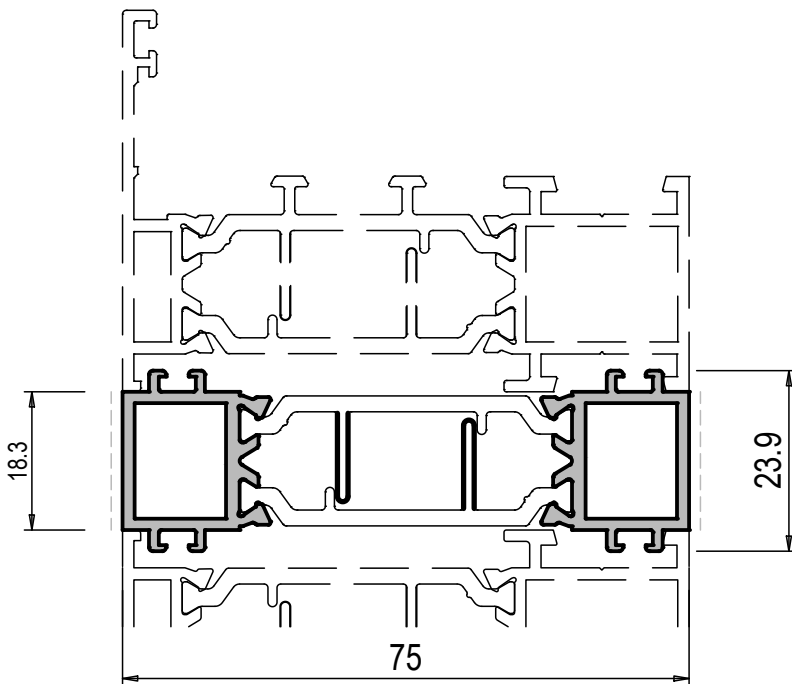

175086

GIUNZIONE TELI A "L"			Jx	cm ⁴
PESO	998		Jy	cm ⁴
S. VISTA	37	Wx	cm ³	
		Wy	cm ³	

665276

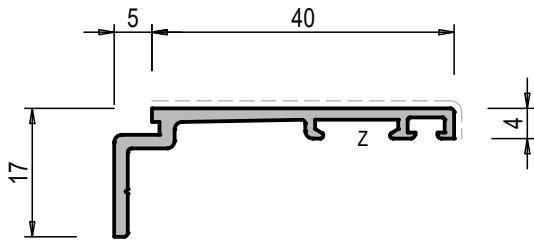

COPRIFILO "A"			Jx cm ⁴	
PESO g/m	306		Jy cm ⁴	
S. VISTA mm	44		Wx cm ³	
			Wy cm ³	

Z	✓	G255				

665277

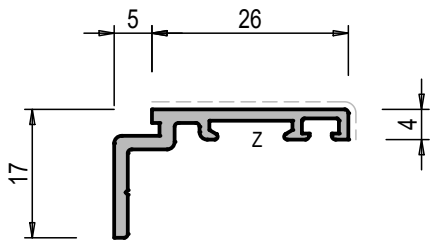

COPRIFILO "B"			Jx cm ⁴	
PESO g/m	244		Jy cm ⁴	
S. VISTA mm	30		Wx cm ³	
			Wy cm ³	

Z	✓	G255				

665278

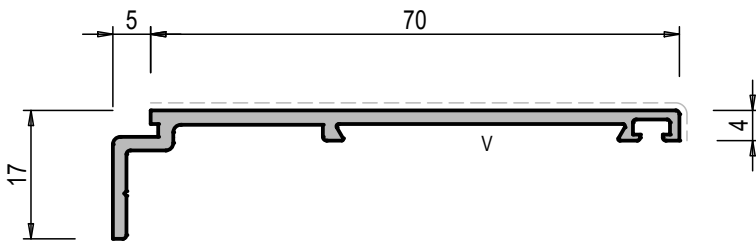

COPRIFILO "C"			Jx cm ⁴	
PESO g/m	475		Jy cm ⁴	
S. VISTA mm	74		Wx cm ³	
			Wy cm ³	

V	✓	G220				

Profilati Scala 1:1

PROFILATI COMPLEMENTARI

40272

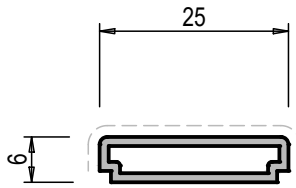

INGLESINA "A" VERTICALE		Jx cm ⁴	
PESO g/m	184	Jy cm ⁴	
S. VISTA mm	34	Wx cm ³	
		Wy cm ³	

40273

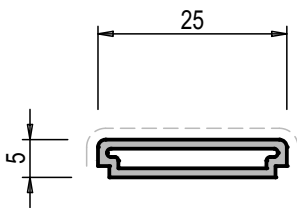

INGLESINA "B" ORIZZONTALE		Jx cm ⁴	
PESO g/m	178	Jy cm ⁴	
S. VISTA mm	33	Wx cm ³	
		Wy cm ³	

50052

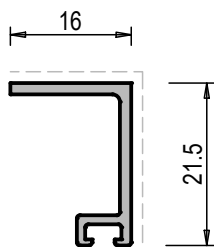

PORTASPAZZOLINO		Jx cm ⁴	
PESO g/m	175	Jy cm ⁴	
S. VISTA mm	----	Wx cm ³	
		Wy cm ³	

40269

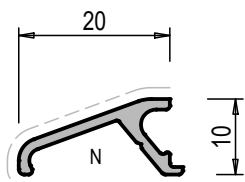

GOCCIOLATOIO UNIVERSALE		Jx cm ⁴	
PESO g/m	141	Jy cm ⁴	
S. VISTA mm	23	Wx cm ³	
		Wy cm ³	

N	GT118	CP. TAPPI		

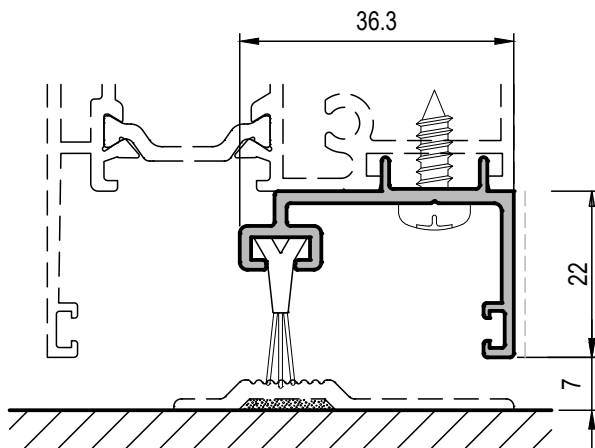

40282

SOTTOPORTA			Jx	cm ⁴
PESO	375		Jy	cm ⁴
S. VISTA	22		Wx	cm ³
			Wy	cm ³

6405

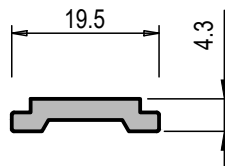

ASTINA CAMERA EUROPEA			Jx	cm ⁴
PESO	159		Jy	cm ⁴
S. VISTA	----		Wx	cm ³
			Wy	cm ³

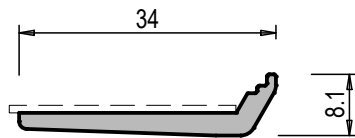

72524

MANINA SUPPORTO VETRO PER ANTA A SCOMPARSA			Jx	cm ⁴
PESO	257		Jy	cm ⁴
S. VISTA	---		Wx	cm ³
			Wy	cm ³

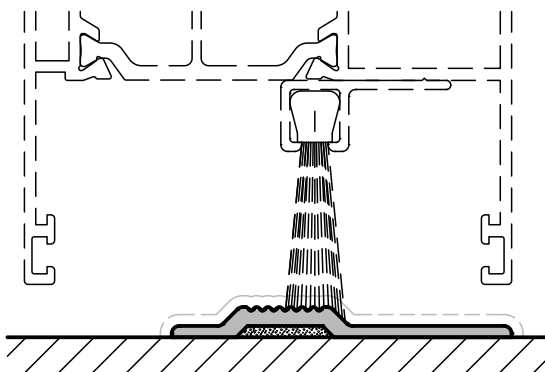

72531

SOGLIA PIATTA			Jx	cm ⁴
PESO	226		Jy	cm ⁴
S. VISTA	52		Wx	cm ³
			Wy	cm ³

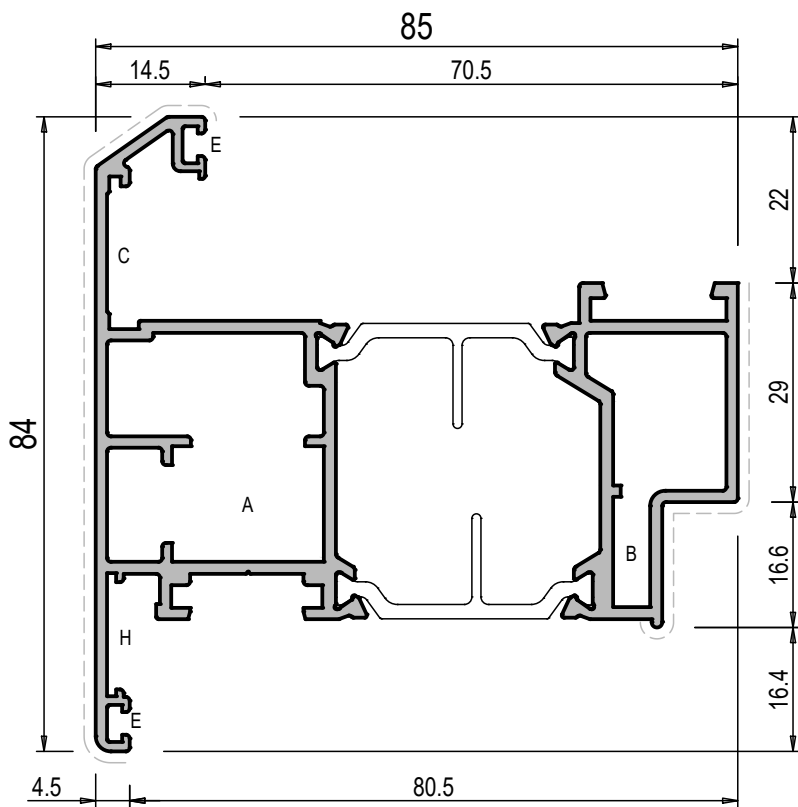

175128

ANTA APERTURA ESTERNA SGUSCIATA DOPPIA BATTUTA		Jx cm ²	20.3
PESO g/m	1920	Jy cm ²	44.8
S. VISTA mm	169	Wx cm ³	4.9
		Wy cm ³	9.8

C	G501N					
E	G112					
F	TS080			GA101		TI001
G	TS081			GA036		TI003
H	G268					

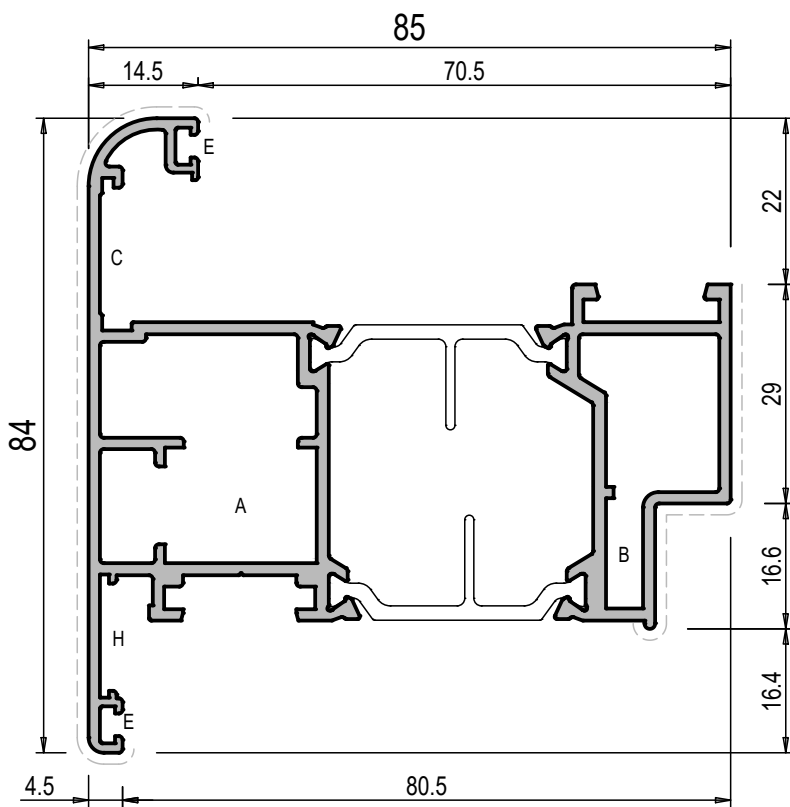

175129

ANTA APERTURA ESTERNA ARROT. DOPPIA BATTUTA		Jx cm ²	20.3
PESO g/m	1924	Jy cm ²	44.8
S. VISTA mm	169	Wx cm ³	4.9
		Wy cm ³	9.8

C	G501N					
E	G112					
F	TS080			GA101		TI001
G	TS081			GA036		TI003
H	G268					

FERMAVETRI

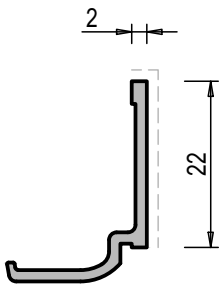

40086	
PESO g/m	178
S. VISTA mm	24

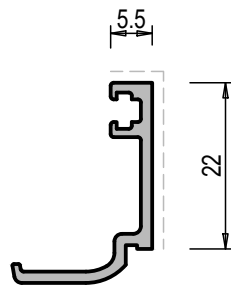

40085	
PESO g/m	210
S. VISTA mm	27

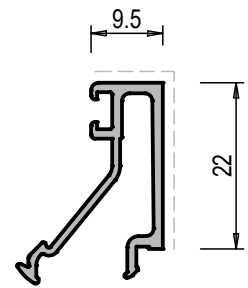

40249	
PESO g/m	242
S. VISTA mm	34

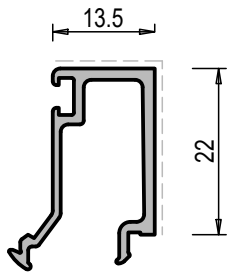

40030	
PESO g/m	263
S. VISTA mm	35

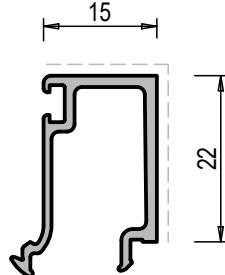

40217	
PESO g/m	267
S. VISTA mm	40

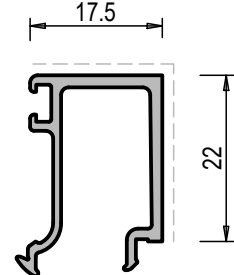

40185	
PESO g/m	280
S. VISTA mm	39

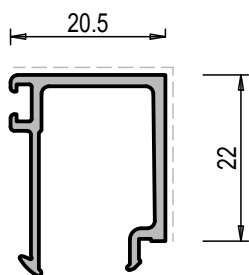

40029	
PESO g/m	283
S. VISTA mm	42

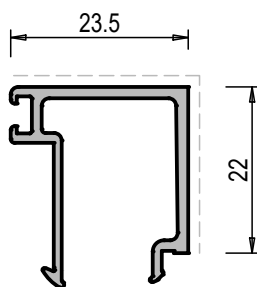

40087	
PESO g/m	303
S. VISTA mm	45

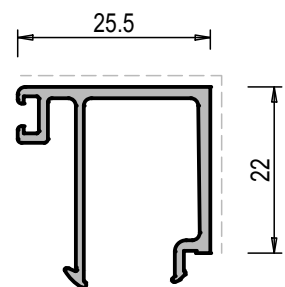

40007	
PESO g/m	318
S. VISTA mm	47

FERMAVETRI

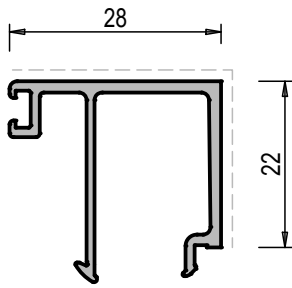

40326	
PESO g/m	329
S. VISTA mm	50

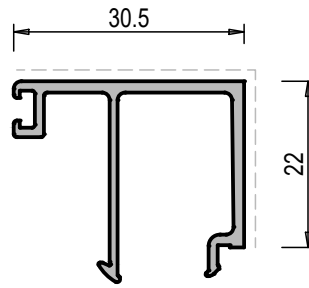

40039	
PESO g/m	339
S. VISTA mm	52

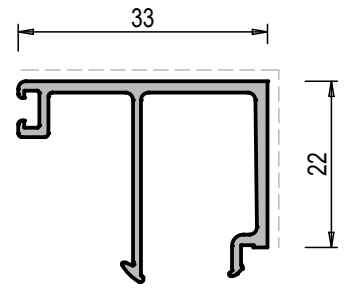

40111	
PESO g/m	347
S. VISTA mm	55

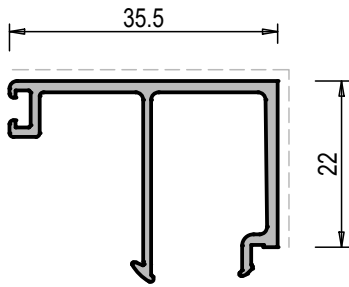

40037	
PESO g/m	359
S. VISTA mm	57

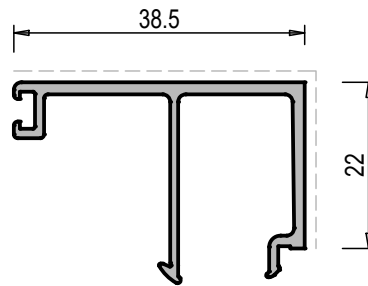

40275	
PESO g/m	379
S. VISTA mm	60

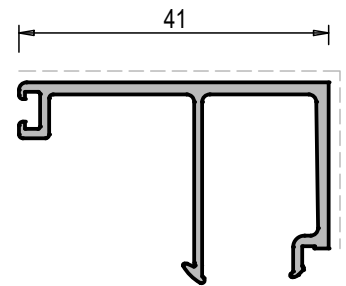

72505	
PESO g/m	392
S. VISTA mm	63

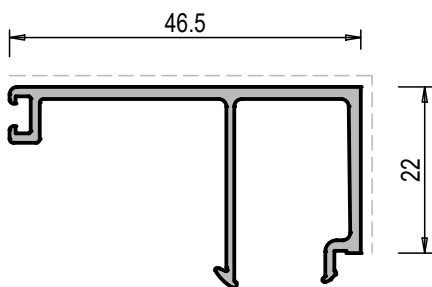

40277	
PESO g/m	414
S. VISTA mm	69

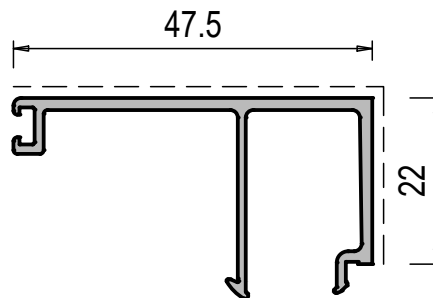

72506	
PESO g/m	420
S. VISTA mm	70

FERMAVETRI

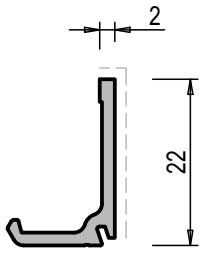

40098	
PESO g/m	169
S. VISTA mm	24

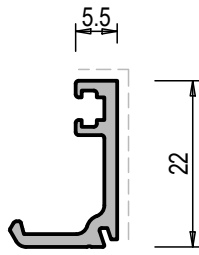

40097	
PESO g/m	199
S. VISTA mm	27

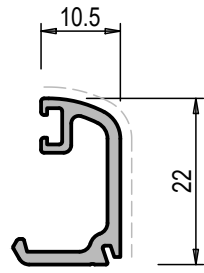

40096	
PESO g/m	221
S. VISTA mm	30

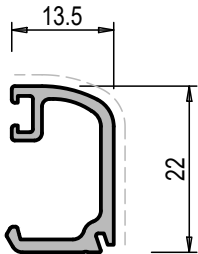

40095	
PESO g/m	236
S. VISTA mm	33

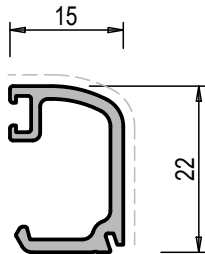

40218	
PESO g/m	243
S. VISTA mm	36

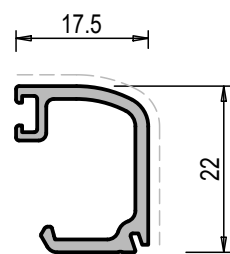

40187	
PESO g/m	254
S. VISTA mm	37

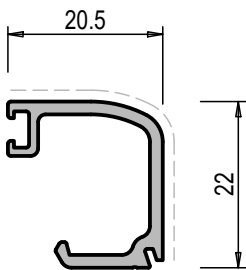

40094	
PESO g/m	268
S. VISTA mm	40

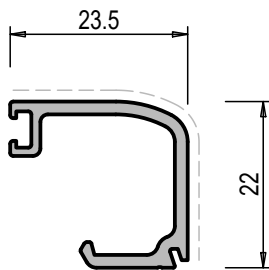

40093	
PESO g/m	282
S. VISTA mm	43

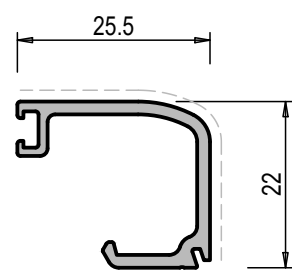

40092	
PESO g/m	291
S. VISTA mm	45

FERMAVETRI

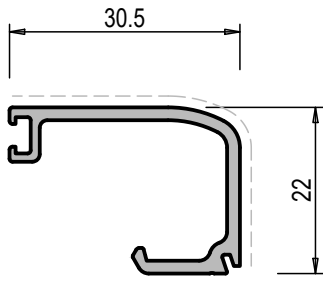

40091	
PESO g/m	324
S. VISTA mm	50

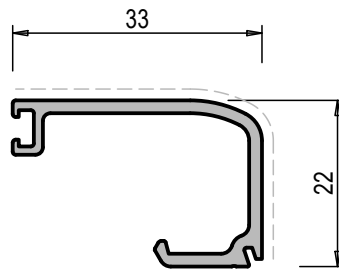

40090	
PESO g/m	336
S. VISTA mm	53

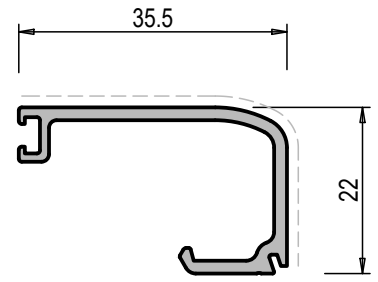

40089	
PESO g/m	348
S. VISTA mm	55

FERMAVETRI

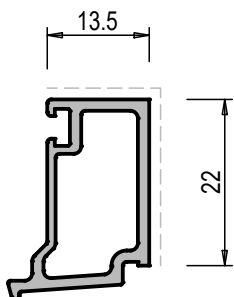

40327	
PESO g/m	311
S. VISTA mm	35.5

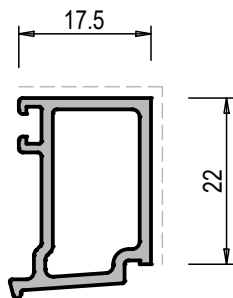

41258	
PESO g/m	342
S. VISTA mm	39.5

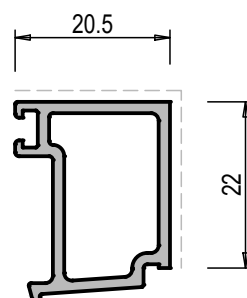

41259	
PESO g/m	359
S. VISTA mm	42.5

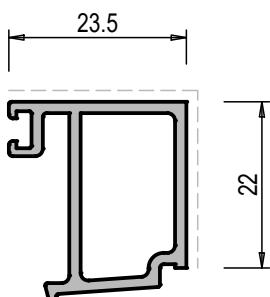

40328	
PESO g/m	425
S. VISTA mm	45.5

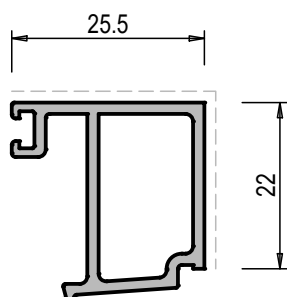

72530	
PESO g/m	395
S. VISTA mm	47.5

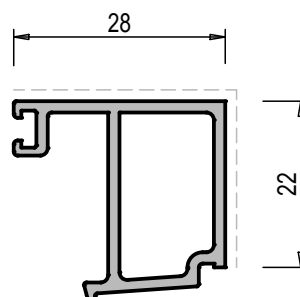

40329	
PESO g/m	405
S. VISTA mm	50

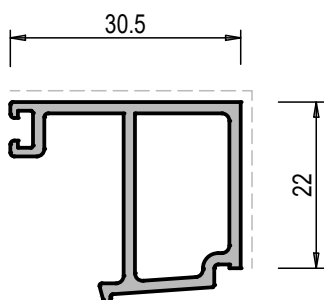

72529	
PESO g/m	415
S. VISTA mm	52.5

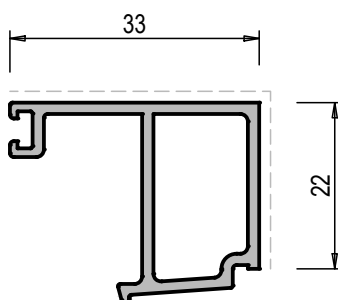

72528	
PESO g/m	425
S. VISTA mm	55

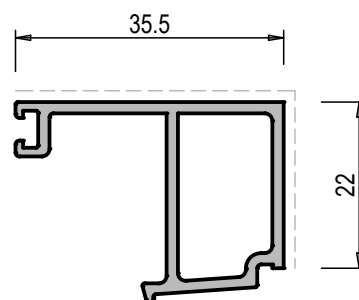

72527	
PESO g/m	435
S. VISTA mm	57.5

FERMAVETRI

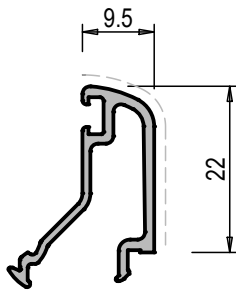

40247	
PESO g/m	229
S. VISTA mm	30

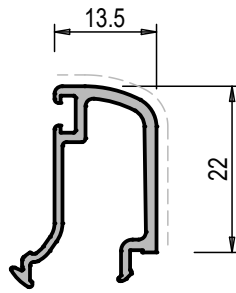

40083	
PESO g/m	252
S. VISTA mm	34

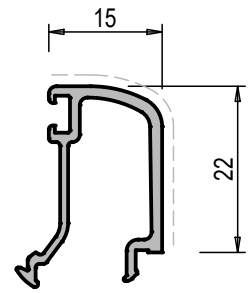

40216	
PESO g/m	259
S. VISTA mm	52.5

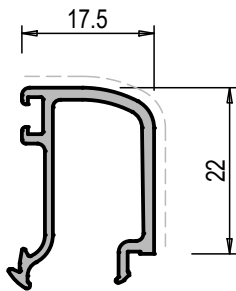

40186	
PESO g/m	272
S. VISTA mm	40

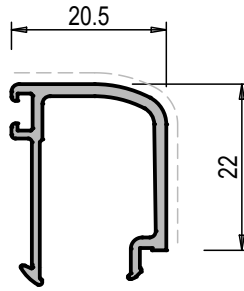

40082	
PESO g/m	274
S. VISTA mm	44

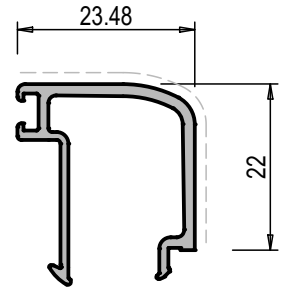

40081	
PESO g/m	293
S. VISTA mm	47

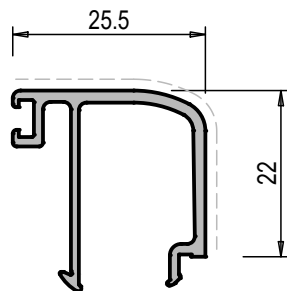

40080	
PESO g/m	312
S. VISTA mm	49

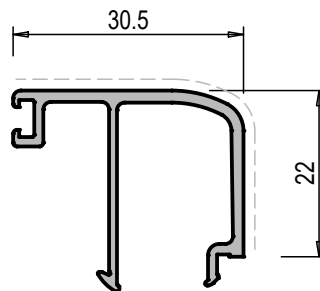

40079	
PESO g/m	332
S. VISTA mm	53

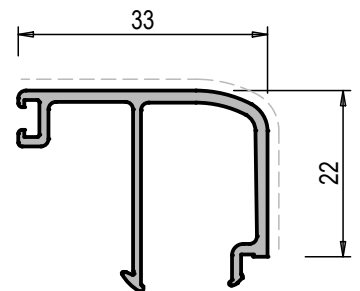

40078	
PESO g/m	342
S. VISTA mm	55

FERMAVETRI

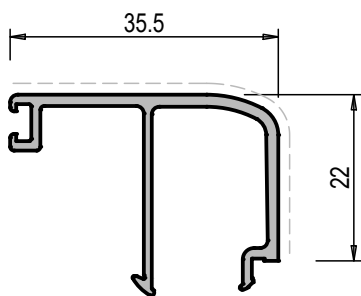

40077	
PESO g/m	352
S. VISTA mm	58

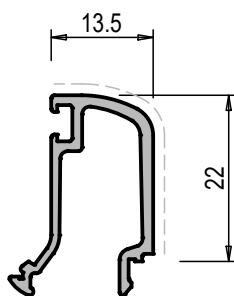

40225	
PESO g/m	261
S. VISTA mm	35

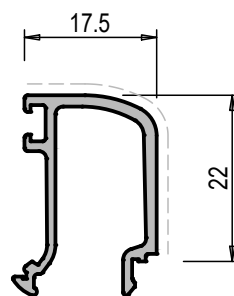

40228	
PESO g/m	278
S. VISTA mm	41

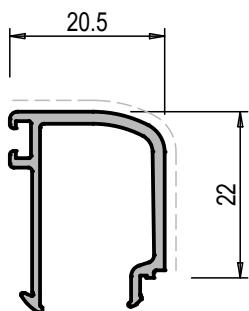

40226	
PESO g/m	270
S. VISTA mm	36

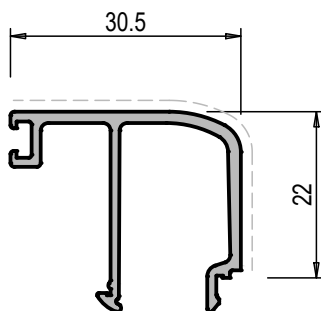

40227	
PESO g/m	341
S. VISTA mm	57

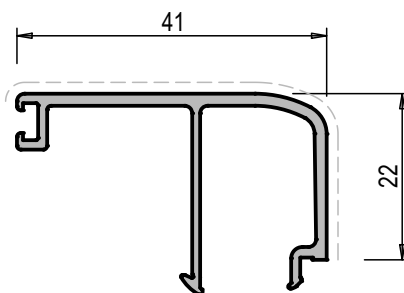

72507	
PESO g/m	380
S. VISTA mm	60

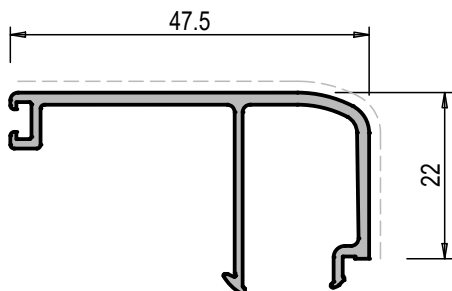

72508	
PESO g/m	416
S. VISTA mm	67

FERMAVETRI

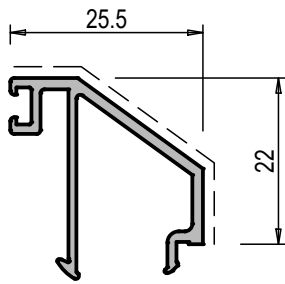

40316	
PESO g/m	283
S. VISTA mm	39

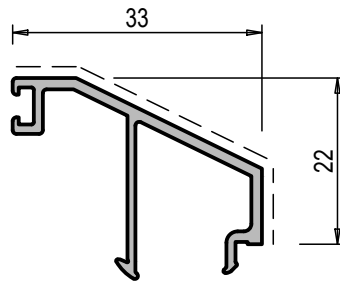

40274	
PESO g/m	298
S. VISTA mm	46

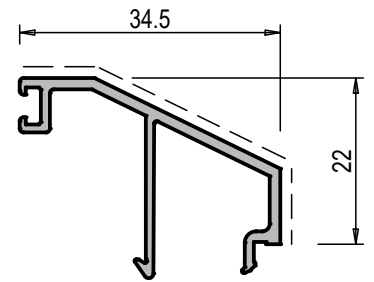

40262	
PESO g/m	302
S. VISTA mm	47

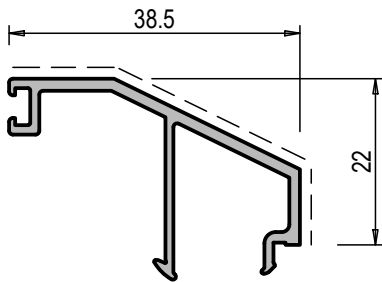

40276	
PESO g/m	330
S. VISTA mm	51

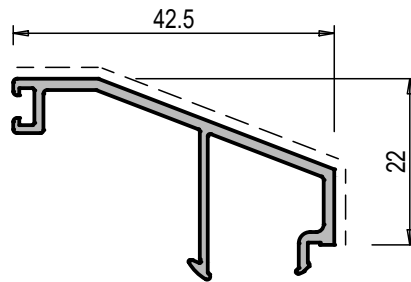

40261	
PESO g/m	327
S. VISTA mm	54

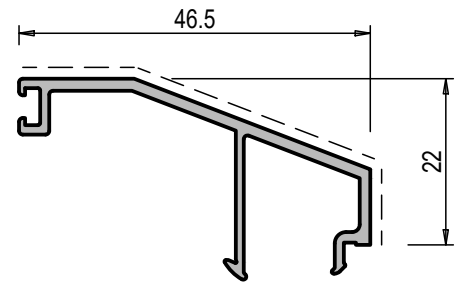

40278	
PESO g/m	357
S. VISTA mm	59

FERMAVETRI

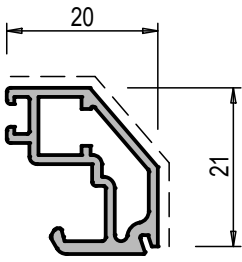

72519	
PESO g/m	303
S. VISTA mm	35

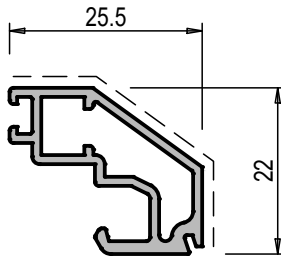

72501	
PESO g/m	331
S. VISTA mm	39

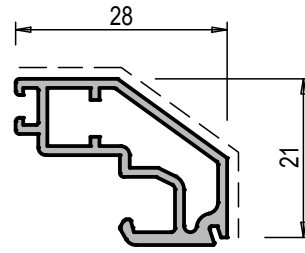

72512	
PESO g/m	348
S. VISTA mm	42

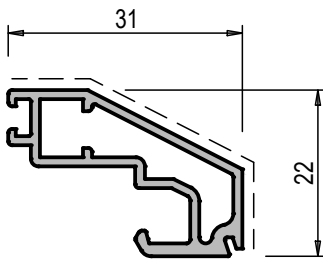

72502	
PESO g/m	364
S. VISTA mm	45

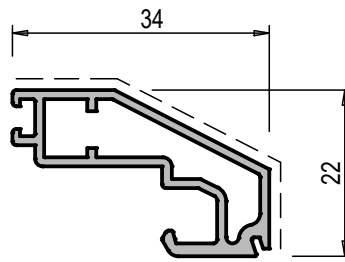

72509	
PESO g/m	382
S. VISTA mm	48

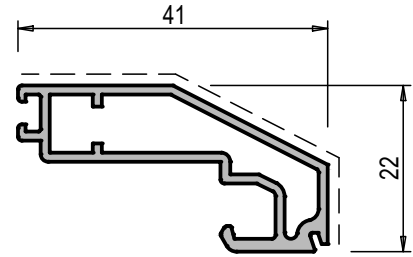

72503	
PESO g/m	428
S. VISTA mm	55

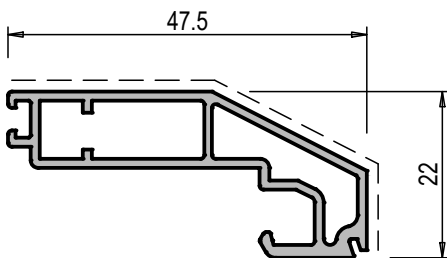

72504	
PESO g/m	492
S. VISTA mm	61

SPEZIO VETRO

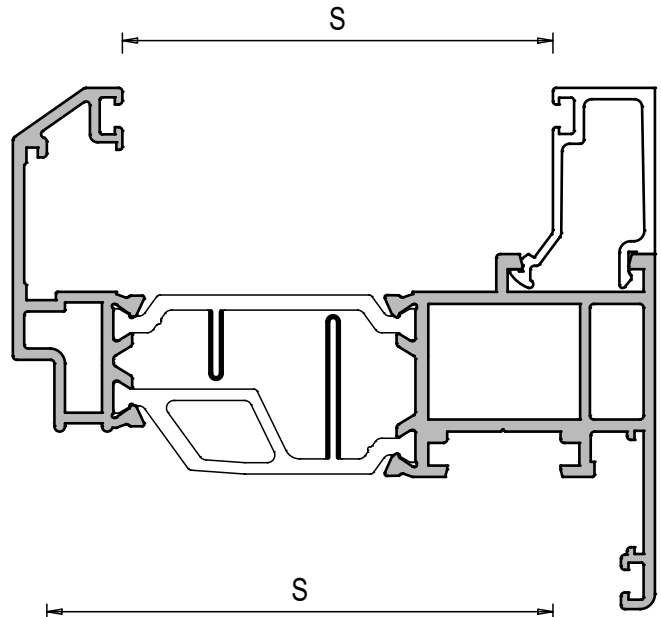
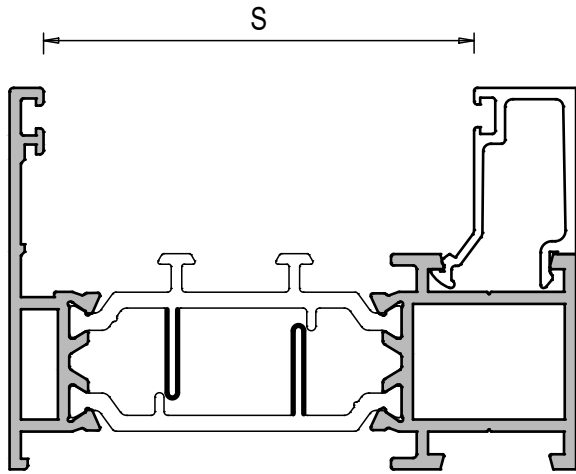

LA MISURA **S** INDICA LO SPAZIO UTILE PER L'ALLOGGIAMENTO DEL VETRO. SOTTRARRE L'INGOMBRO DELLA GUARNIZIONE CINGIVETRO INTERNA ED ESTERNA CHE VIENE UTILIZZATA

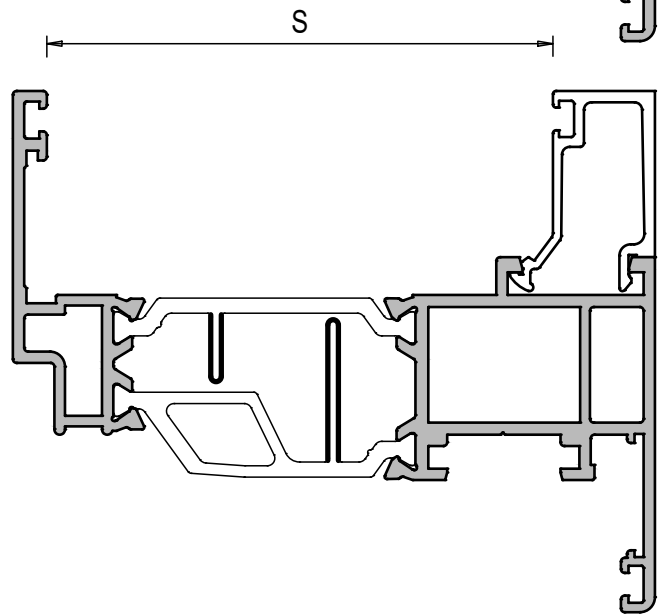

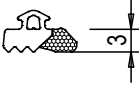

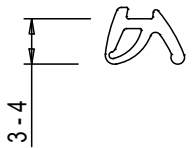
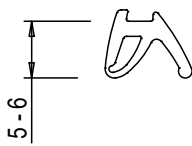
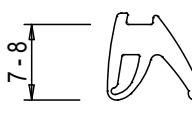
CINGIVETRO ESTERNA	
	<p>TG032</p> <p>DA mm 3</p>

CINGIVETRO INTERNA	
	<p>TG304</p> <p>DA mm 3</p> <p>A mm 4</p>
	<p>TG305</p> <p>DA mm 5</p> <p>A mm 6</p>
	<p>TG306</p> <p>DA mm 5</p> <p>A mm 6</p>

APPLICAZIONE FERMAVETRI

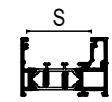

MISURE FERMAVETRO	PIANI	ARROTONDATI	CLIP	CONTRASTO	DESIGN	DESIGN CLIP		
2 mm	40086		40098				S = 68.5	S = 78.5
5.5 mm	40085		40097				S = 65	S = 75
9.5 mm	40249	40247					S = 61	S = 71
10.5 mm	40031		40096				S = 60	S = 70
13.5 mm	40030	40083	40095	40327			S = 57	S = 67
15 mm	40217	40216	40218				S = 55.5	S = 65.5
17.5 mm	40185	40186	40187	41258			S = 53	S = 63
20 mm						72519	S = 50.5	S = 60.5
20.5 mm	40029	40082	40094	41259			S = 50	S = 60
23.5 mm	40087	40081	40093	40328			S = 47	S = 57
25.5 mm	40007	40080	40092	72530	40316	72501	S = 45	S = 55
28 mm				40329		72512	S = 42.5	S = 52.5
30.5 mm	40039	40079	40091	72529			S = 40	S = 50
31 mm						72502	S = 39.5	S = 49.5
33 mm	40111	40078	40090	72528	40274		S = 37.5	S = 47.5
34 mm						72509	S = 36.5	S = 46.5
34.5 mm					40262		S = 36	S = 46
35.5 mm	40037	40077	40089	72527			S = 35	S = 45
38.5 mm	40275				40276		S = 32	S = 42
41 mm	72505	72507				72503	S = 29.5	S = 39.5
42.5 mm					40261		S = 28	S = 38
46.5 mm	40277				40278		S = 24	S = 34
47.5 mm	72506	72508				72504	S = 23	S = 33
52.5 mm	40279				40280		S = 18	S = 28

MONTAGGIO FERMAVETRI

LA ROTAZIONE DEL FERMAVETRO IN FASE DI MONTAGGIO OCCUPA UNO SPAZIO DI 4mm.
PER L'INSERIMENTO AGEVOLE, CONSIDERARE UNO SPAZIO ANCORA MAGGIORE.

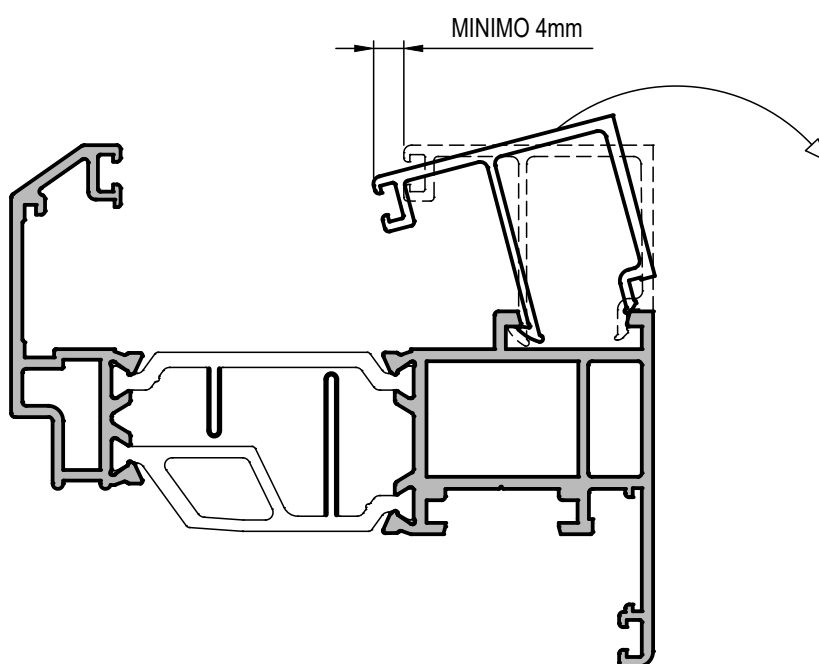

N.B. PRIMA DI ESEGUIRE IL LAVORO, CONTROLLARE COMUNQUE CHE LA ROTAZIONE DEL FERMAVETRO AVVENGA REGOLARMENTE E NON SIA INFLUENZATA ANCHE DA EVENTUALI TOLLERANZE DEL VETROCAMERA.

LA ROTAZIONE DEL FERMAVETRO IN FASE DI MONTAGGIO OCCUPA UNO SPAZIO DI 4mm.

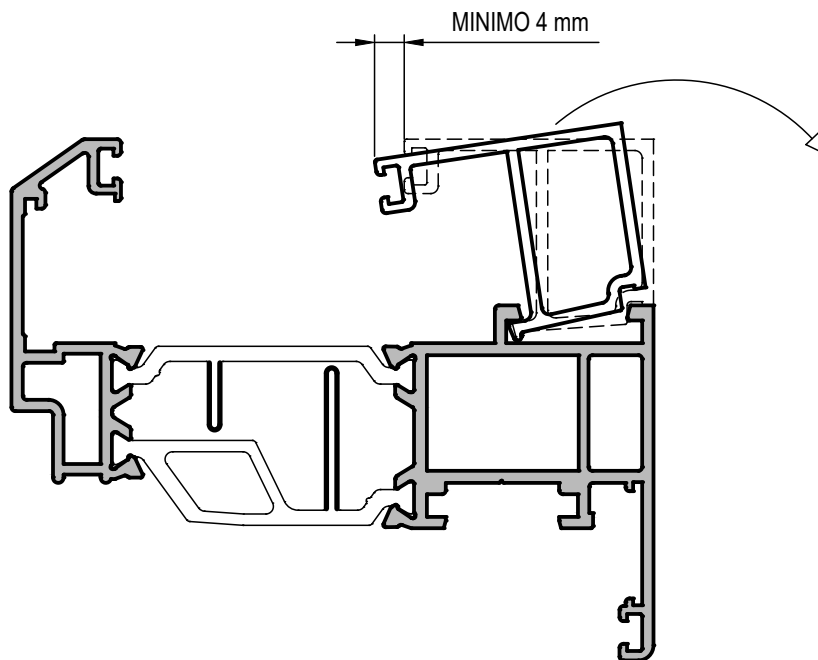

N.B. PRIMA DI ESEGUIRE IL LAVORO, CONTROLLARE COMUNQUE CHE LA ROTAZIONE DEL FERMAVETRO AVVENGA REGOLARMENTE E NON SIA INFLUENZATA ANCHE DA EVENTUALI TOLLERANZE DEL VETROCAMERA.
DURANTE LA FASE DI TRASPORTO INSERIRE UNO SPESSORE PER STABILIZZARE I FERMAVETRI.





Soluzioni Disponibili 

SEZIONE TIPO DOGMA PRO

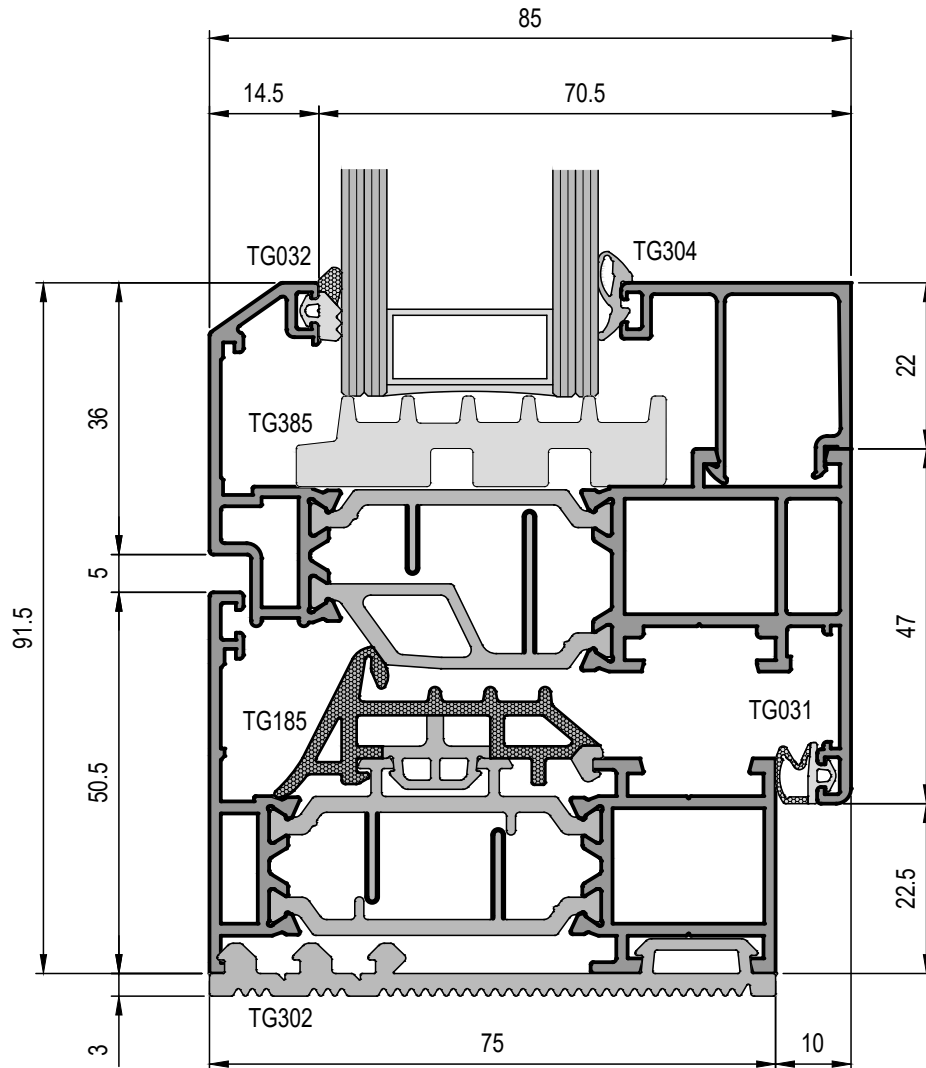

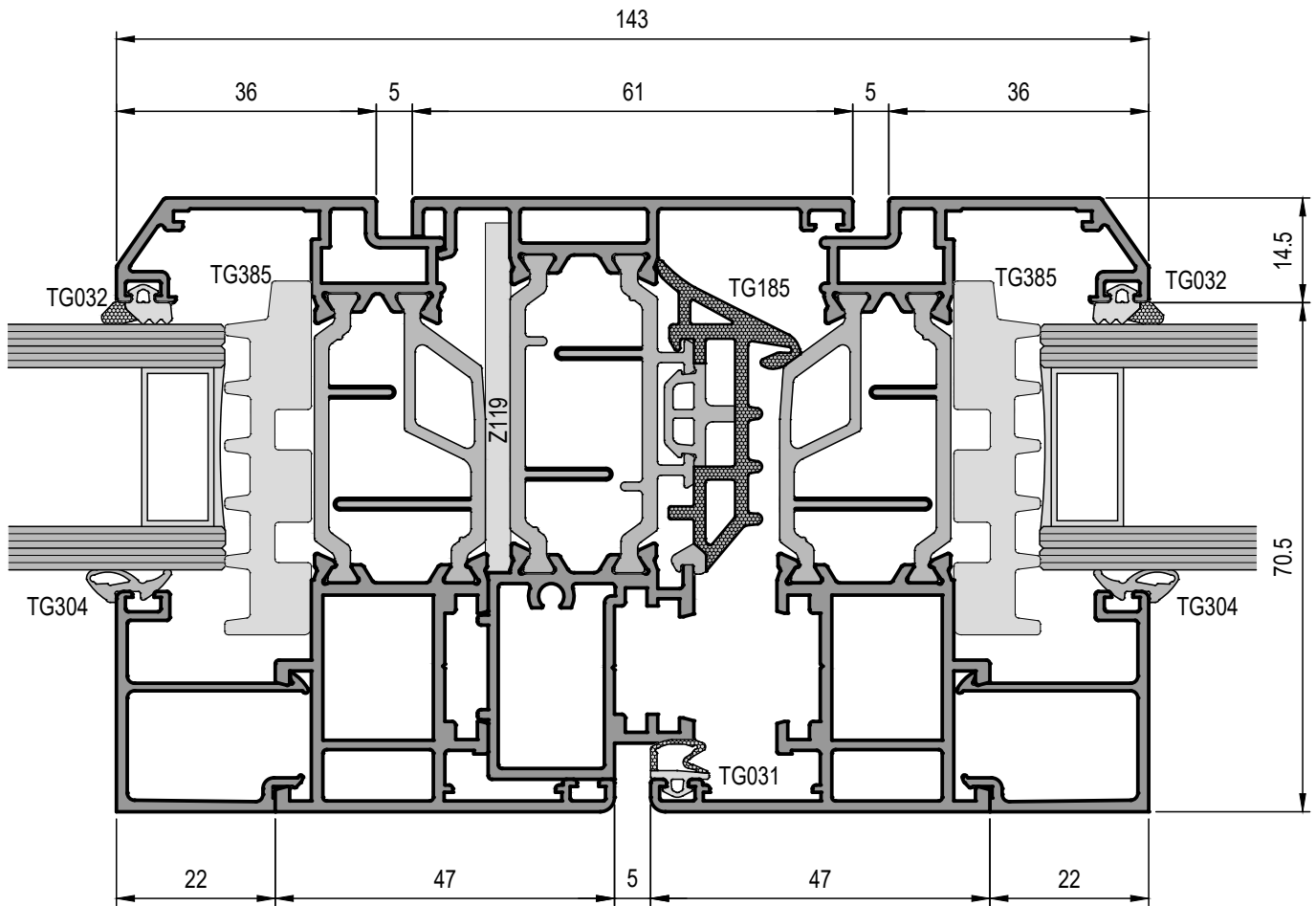

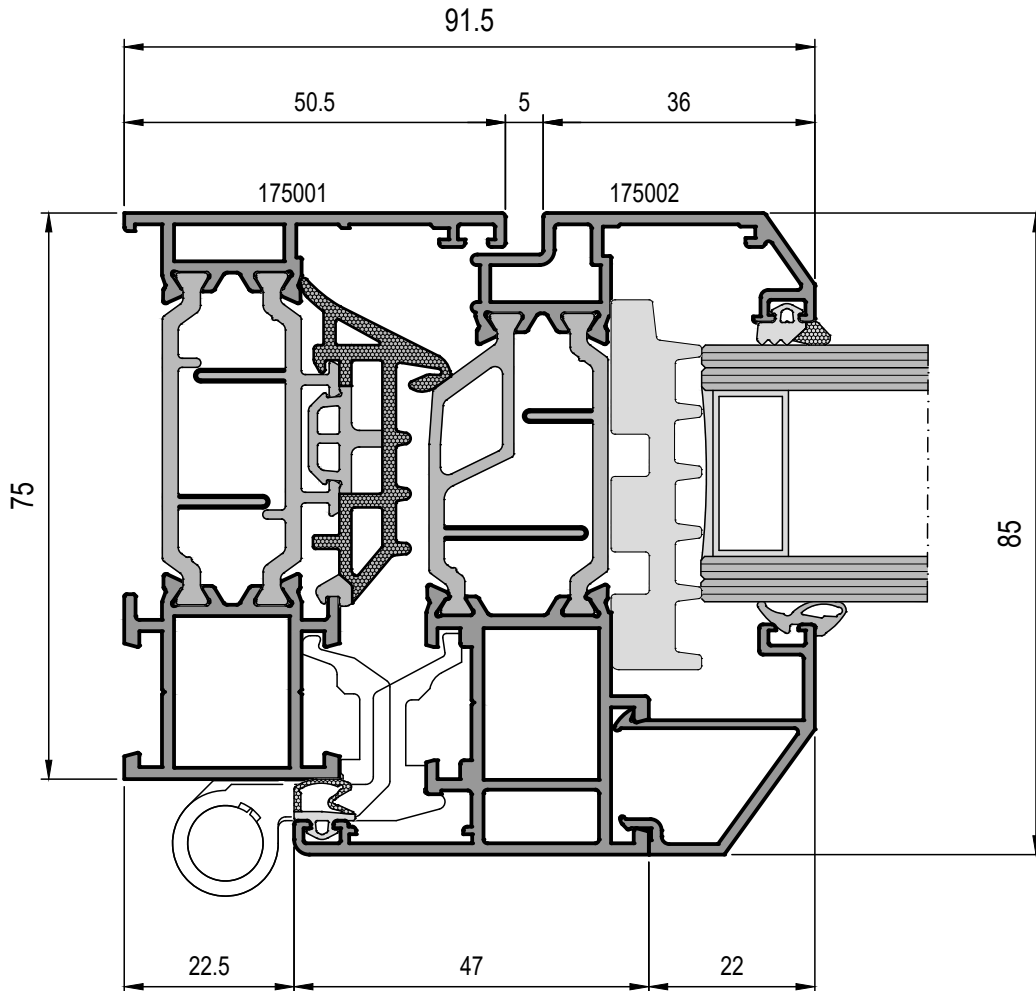
**LINEA SGUSCIATA**

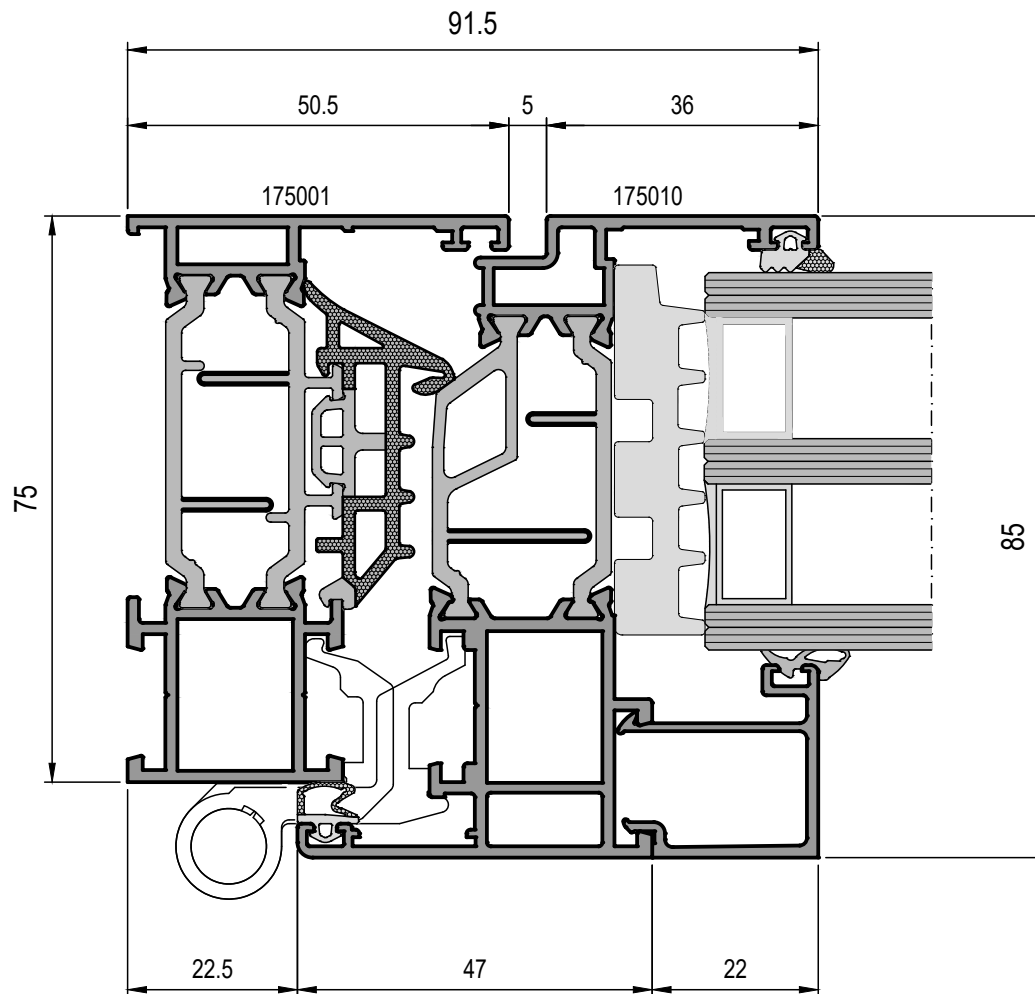

LINEA PIANA

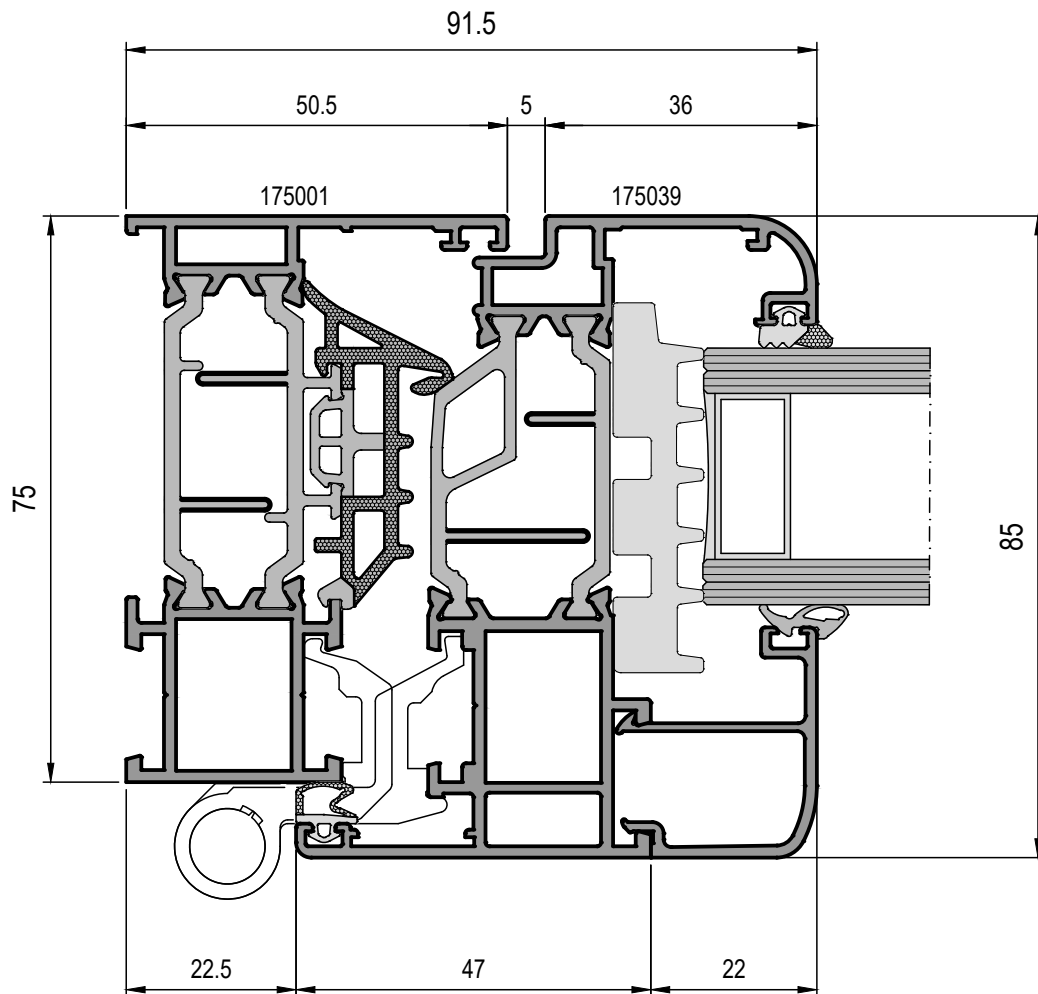
**LINEA ARROTONDATA**

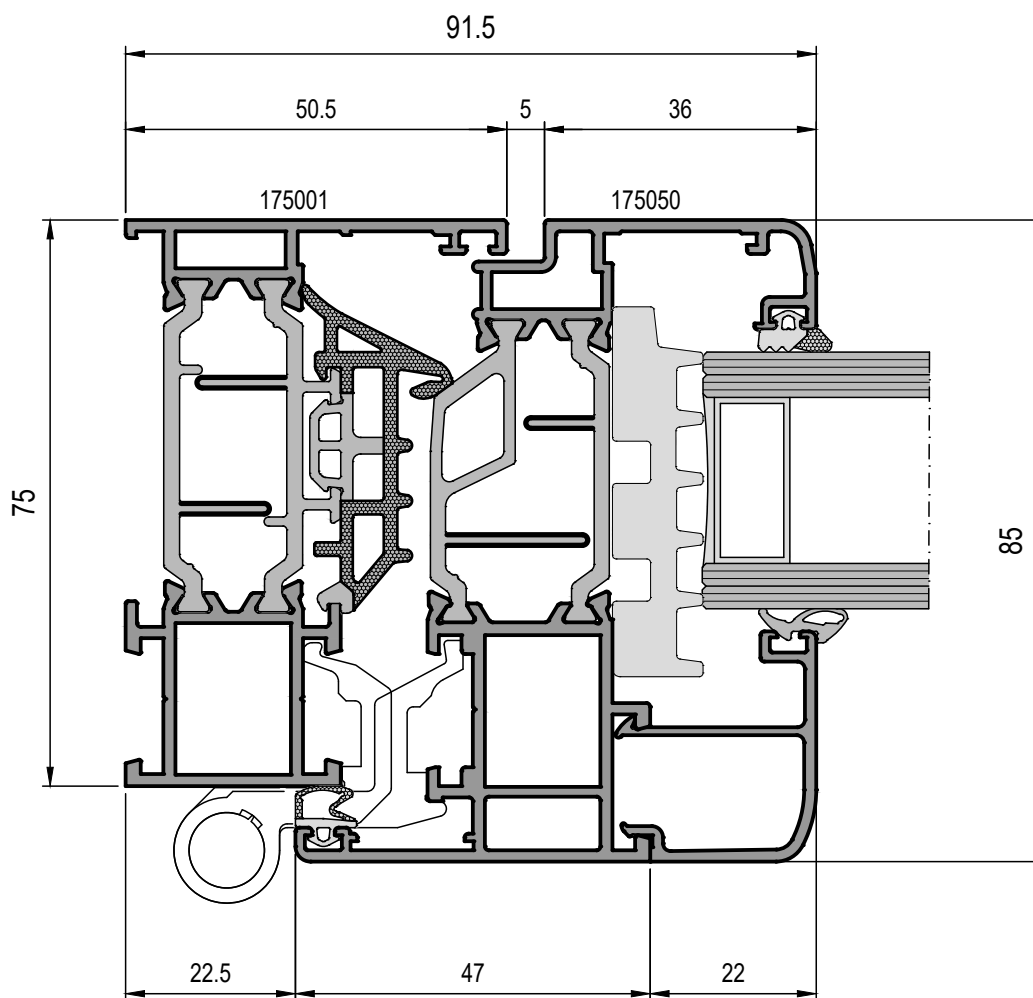

LINEA STORICA



Schede di Taglio 

DISTINTA ACCESSORI

CODICE	DESCRIZIONE	N°
TA075	REGOLO TELAIO CAMERA SEMPLICE	TABELLA
G2001	VITE PER SQUADRETTA TS078	16
G2002 *	SPINA PER SQUADRETTA TS078	
TS077	SQUADRETTA A PULSANTE PER TELAIO ED ANTA	8
TS078 *	SQUADRETTA A SPINARE-CIANFRINARE TELAIO ED ANTA	
G501N	SQUADRETTA A CAMME PER TELAIO E ANTA	8
TS079	SQUADRETTA ANTA E TELAIO TUBOLARITÀ ESTERNA	8
S3001	SPINA MM 3 PER SQUADRETTA TS079	8
G112	SQUADRETTA INOX DI ALLINEAMENTO ANGOLI	4
G268	SQUADRETTA ALLINEAMENTO ANTE	4
G269	SQUADRETTA ALLINEAMENTO TELAI	2
G101	CAPPETTA DRENAGGIO ACQUA	2 ... 3
G231*	ANGOLO PRESSOFUSO PER FERMAVETRI ARROTONDATI	4
* IN ALTERNATIVA		

N.B. : PER GLI ACCESSORI DI CHIUSURA, MOVIMENTAZIONE E LIMITI PRESTAZIONALI CONSULTARE IL MANUALE DEL FORNITORE DEGLI ACCESSORI.

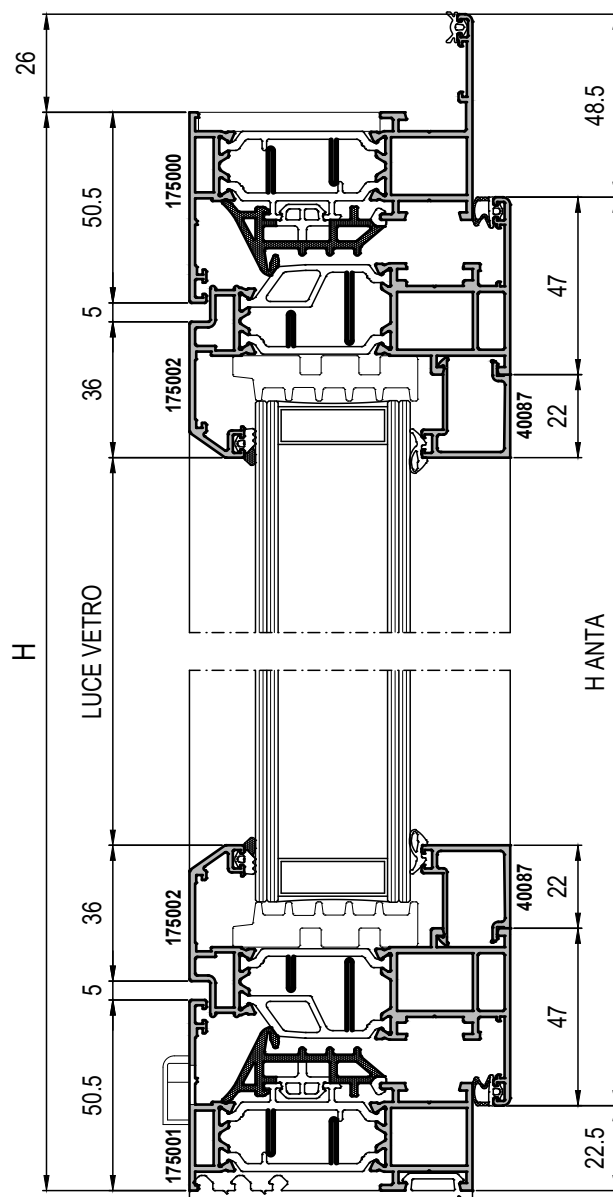



















DISTINTA GUARNIZIONI

CODICE	DESCRIZIONE	N°
TG186	ANGOLO VULCANIZZATO	4 Pz.
TG185	GUARNIZIONE DI TENUTA CENTRALE	2L+2H
TG031	GUARNIZIONE DI BATTUTA	2L+2H
	GUARNIZIONE CINGIVETRO ESTERNA	2L+2H
	GUARNIZIONE CINGIVETRO INTERNA	2L+2H
TG302	GUARNIZIONE PERIMETRALE ISOLANTE	L
TG004	GUARNIZIONE BATTUTA A MURO / BATTUTA ESTERNA	L+2H
TG385	SOTTOVETRO ISOLANTE	2L+2H
Z119	GUARNIZIONE ISOLANTE	L+2H
* IN ALTERNATIVA		

FINESTRA A DUE ANTE GIUNTO APERTO APERTURA INTERNA

DISTINTA PROFILATI

CODICE	PROFILATO	DESCRIZIONE	MISURA TAGLIO	TAGLIO	N°
175000		TELAIO Z	L + 52		1
			H + 52		2
175001		TELAIO L	L		1
175002		ANTA Z	L/2 - 25		4
			H - 45		4
175003		RIPORTO	H - 111		1
40087		FERMAVETRO	L/2 - 119		4
			H - 183		4
40081 *		FERMAVETRO	L/2 - 163		4
			H - 183		4
6405		ASTINA DI COMANDO	DIPENDE DA ACCESSORIO DI COMANDO		DIPENDE DA ACCESSORIO DI COMANDO

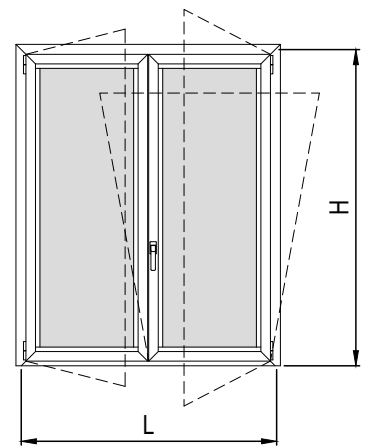

VISTA INTERNA

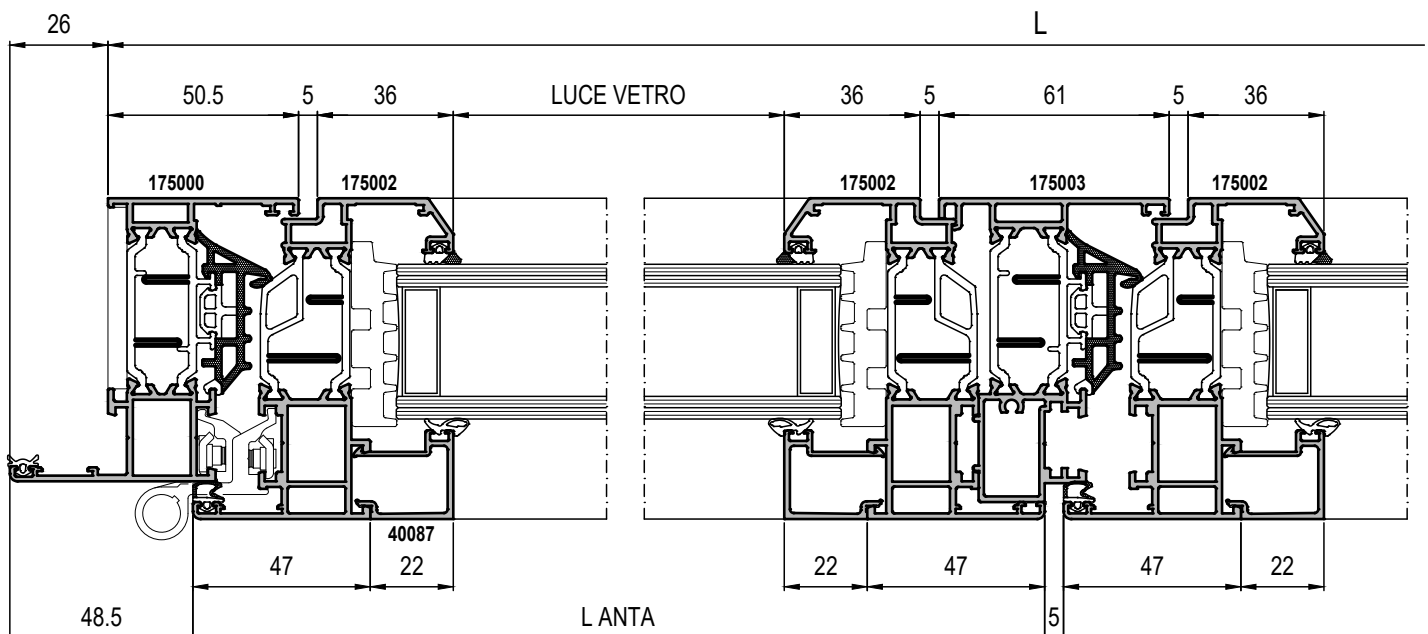

DISTINTA ACCESSORI

CODICE	DESCRIZIONE	N°
TA075	REGOLO TELAIO CAMERA SEMPLICE	TABELLA
G2001	VITE PER SQUADRETTA TS078	24
G2002 *	SPINA PER SQUADRETTA TS078	
TS077	SQUADRETTA A PULSANTE PER TELAIO ED ANTA	12
TS078 *	SQUADRETTA A SPINARE-CIANFRINARE PER TELAIO ED ANTA	
G501N	SQUADRETTA A CAMME PER ANTE	12
TS079	SQUADRETTA ANTA E TELAIO TUBOLARITÀ ESTERNA	12
S3001	SPINA MM 3 PER SQUADRETTA TS079	24
G112	SQUADRETTA INOX DI ALLINEAMENTO ANGOLI	4
G268	SQUADRETTA ALLINEAMENTO ANTE	8
G269	SQUADRETTA ALLINEAMENTO TELAIO	2
TT085	COPPIA TAPPI RIPORTO CENTRALE	1 Cp.
G101	CAPPETTA DI DRENAGGIO ACQUA	2...4
G231*	ANGOLO PRESSOFUSO PER FERMAVETRI ARROTONDATI	8
* IN ALTERNATIVA		

N.B. : PER GLI ACCESSORI DI CHIUSURA, MOVIMENTAZIONE E LIMITI PRESTAZIONALI CONSULTARE IL MANUALE DEL FORNITORE DEGLI ACCESSORI.

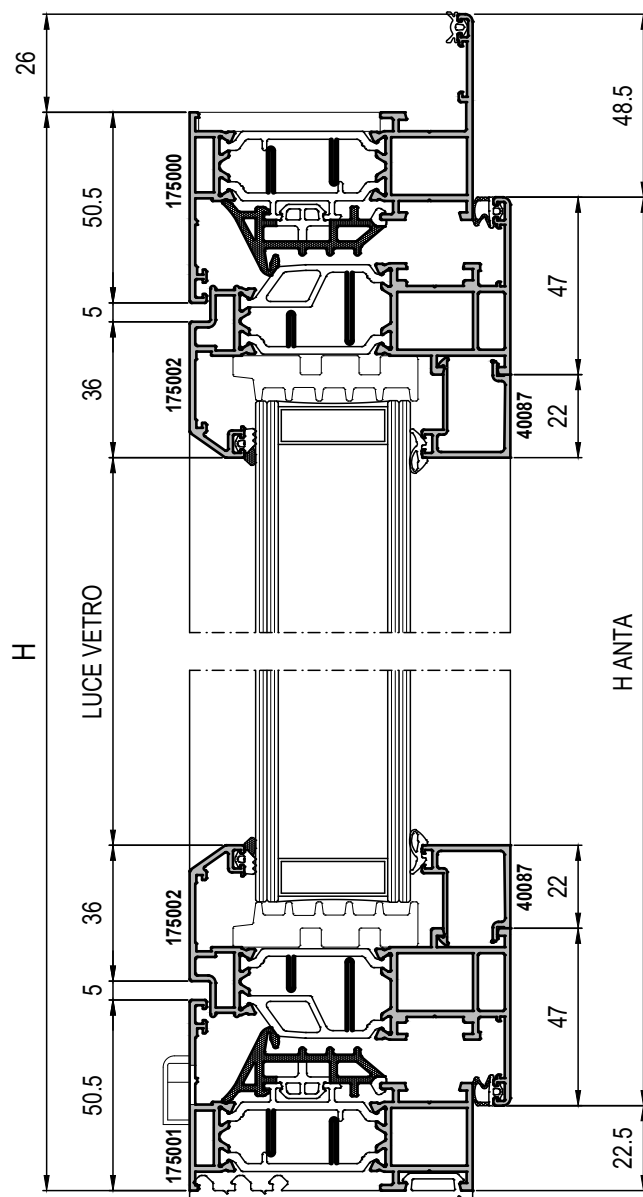
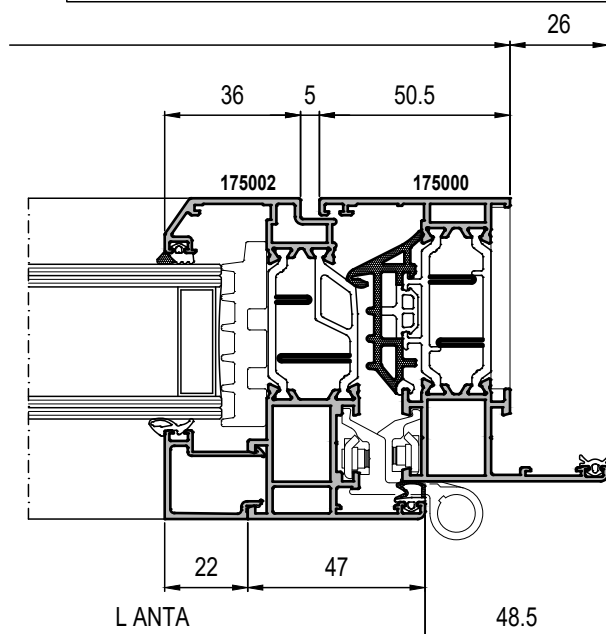

























DISTINTA GUARNIZIONI

CODICE	DESCRIZIONE	N°
TG186	ANGOLO VULCANIZZATO	4 Pz.
TG185	GUARNIZIONE DI TENUTA CENTRALE	2L+3H
TG031	GUARNIZIONE DI BATTUTA	2L+4H
	GUARNIZIONE CINGIVETRO ESTERNA	2L+4H
	GUARNIZIONE CINGIVETRO INTERNA	2L+4H
TG302	GUARNIZIONE PERIMETRALE ISOLANTE	L
TG004	GUARNIZIONE BATTUTA A MURO	L+2H
TG385	SOTTOVETRO ISOLANTE	2L+4H
Z119	GUARNIZIONE ISOLANTE	L+2H
* IN ALTERNATIVA		

PORTAFINESTRA A DUE ANTE GIUNTO APERTO APERTURA INTERNA

DISTINTA PROFILATI

CODICE	PROFILATO	DESCRIZIONE	MISURA TAGLIO	TAGLIO	N°
175000		TELAIO Z	L + 52		1
			H + 52		2
175002		ANTA Z	L/2 - 25		4
			H - 30		4
175003		RIPORTO	H - 96		1
40087		FERMAVETRO	L/2 - 119		8
			H1 - 212,75		4
			H2 - 127,75		4
40081 *		FERMAVETRO	L/2 - 163		8
			H1 - 212,75		4
			H2 - 127,75		4
175087		SOGLIA RIBASSATA	L - 47.5		1
175024		ZOCCOLO RIPIORTATO	L/2 - 109.5		2
175020		TRAVERSO	L/2 - 109.5		2
6405		ASTINA DI COMANDO	DIPENDE DA ACCESSORIO DI COMANDO		DIPENDE DA ACCESSORIO DI COMANDO

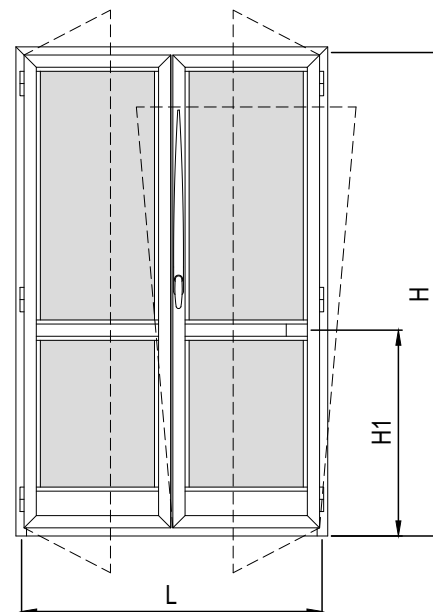

VISTA INTERNA

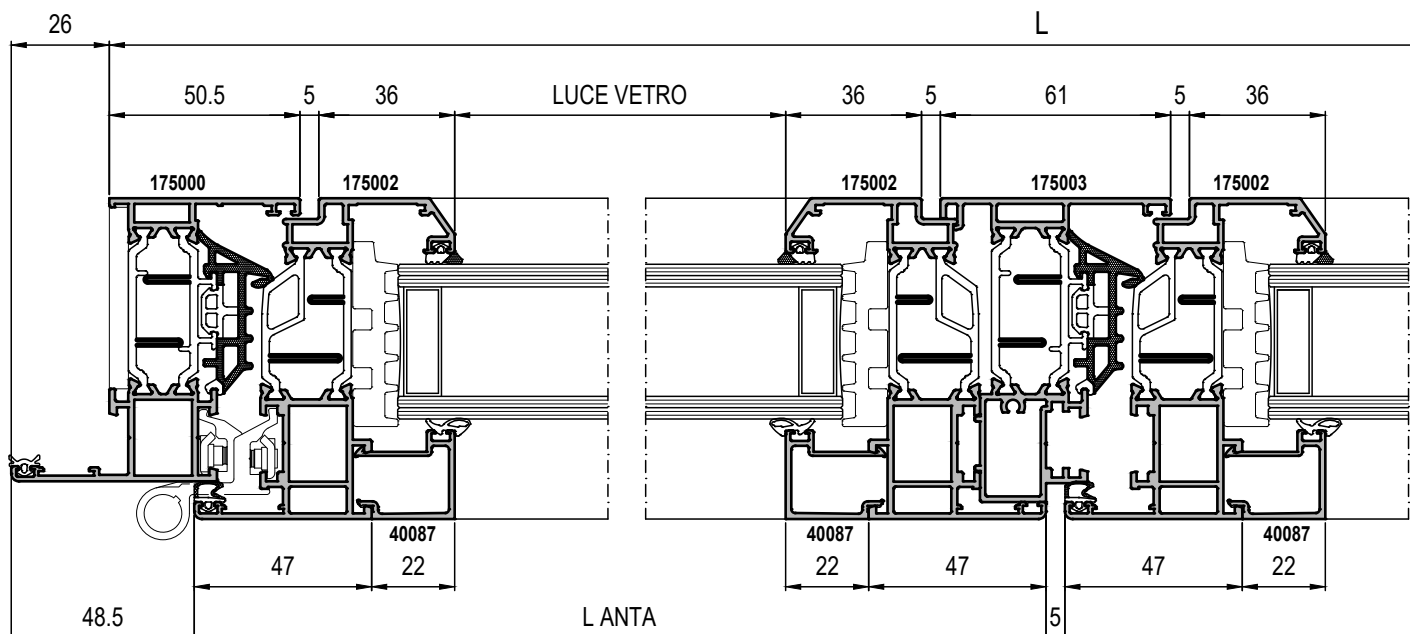

DISTINTA ACCESSORI

CODICE	DESCRIZIONE	N°
TA075	REGOLO TELAIO CAMERA SEMPLICE	TABELLA
G2001	VITE PER SQUADRETTA TS078	24
G2002 *	SPINA PER SQUADRETTA TS078	
TS077	SQUADRETTA A BOTTONE PER TELAIO ED ANTA	12
TS078 *	SQUADRETTA A SPINARE-CIANFRINARE PER TELAIO ED ANTA	
G501N	SQUADRETTA A CAMME PER ANTE	10
TS079	SQUADRETTA ANTA E TELAIO TUBULARITÀ ESTERNA	10
G501N	CAVALLOTTO ESTERNO	12
TS082	PLACCHETTA DI COMPENSAZIONE PER G501N CAVALLOTTO	8
G199	CAVALLOTTO INTERNO	4
TS073	CAVALLOTTO ESTERNO	4
S3001	SPINA MM 3 PER SQUADRETTA TS079	20
G112	SQUADRETTA INOX DI ALLINEAMENTO ANGOLI	2
G268	SQUADRETTA ALLINEAMENTO ANTE	8
G269	SQUADRETTA ALLINEAMENTO TELAI	2
TT065	COPPIA TAPPI RIPORTO CENTRALE	1 Cp.
G101	CAPPETTA DI DRENAGGIO ACQUA	2..4
G231*	ANGOLO PRESSOFUSO PER FERMAVETRI ARROTONDATI	8
* IN ALTERNATIVA		

DISTINTA GUARNIZIONI

CODICE	DESCRIZIONE	N°
TG186	ANGOLO VULCANIZZATO	4 Pz.
TG185	GUARNIZIONE DI TENUTA CENTRALE	2L+3H
TG031	GUARNIZIONE DI BATTUTA	2L+4H
	GUARNIZIONE CINGIVETRO ESTERNA	4L+4H
	GUARNIZIONE CINGIVETRO INTERNA	4L+4H
TG004	GUARNIZIONE BATTUTA A MURO	L+2H
TG385	SOTTOVETRO ISOLANTE	4L+4H
Z119	GUARNIZIONE ISOLANTE	L+4H
* IN ALTERNATIVA		

N.B. : PER GLI ACCESSORI DI CHIUSURA, MOVIMENTAZIONE E LIMITI PRESTAZIONALI CONSULTARE IL MANUALE DEL FORNITORE DEGLI ACCESSORI.

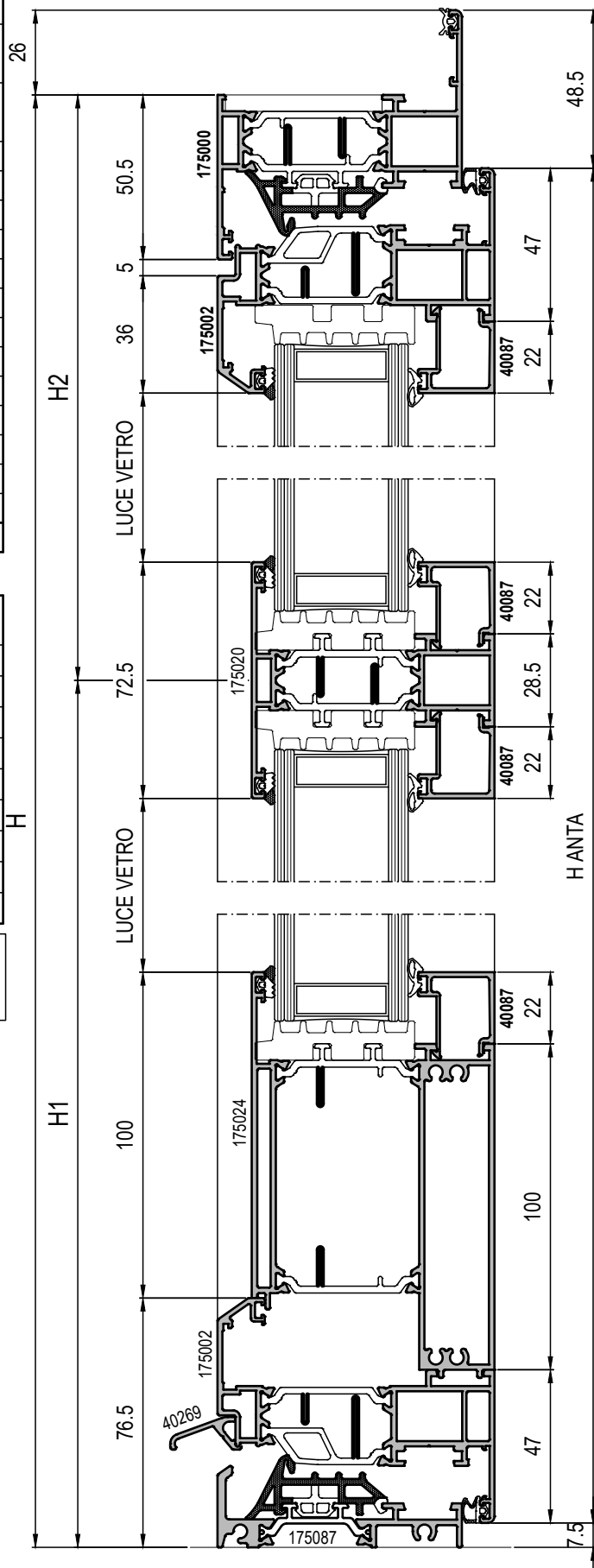
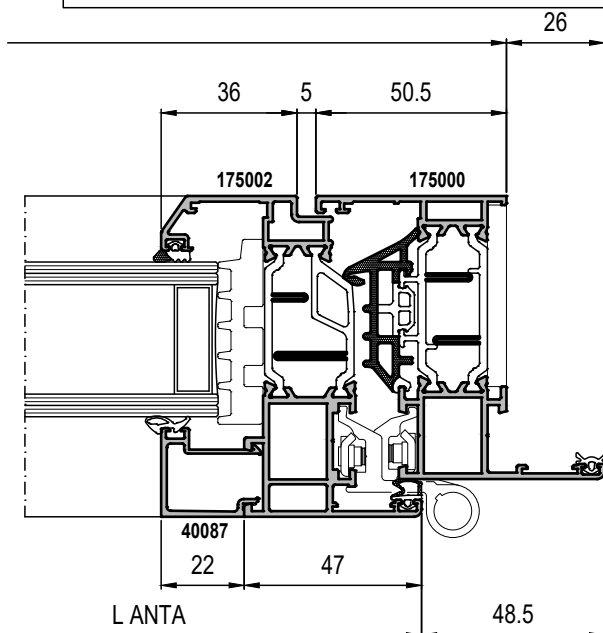



Nodi Scala 1:1 

FISSO

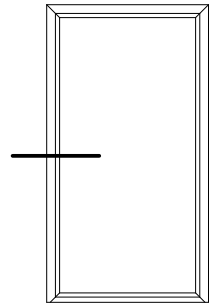
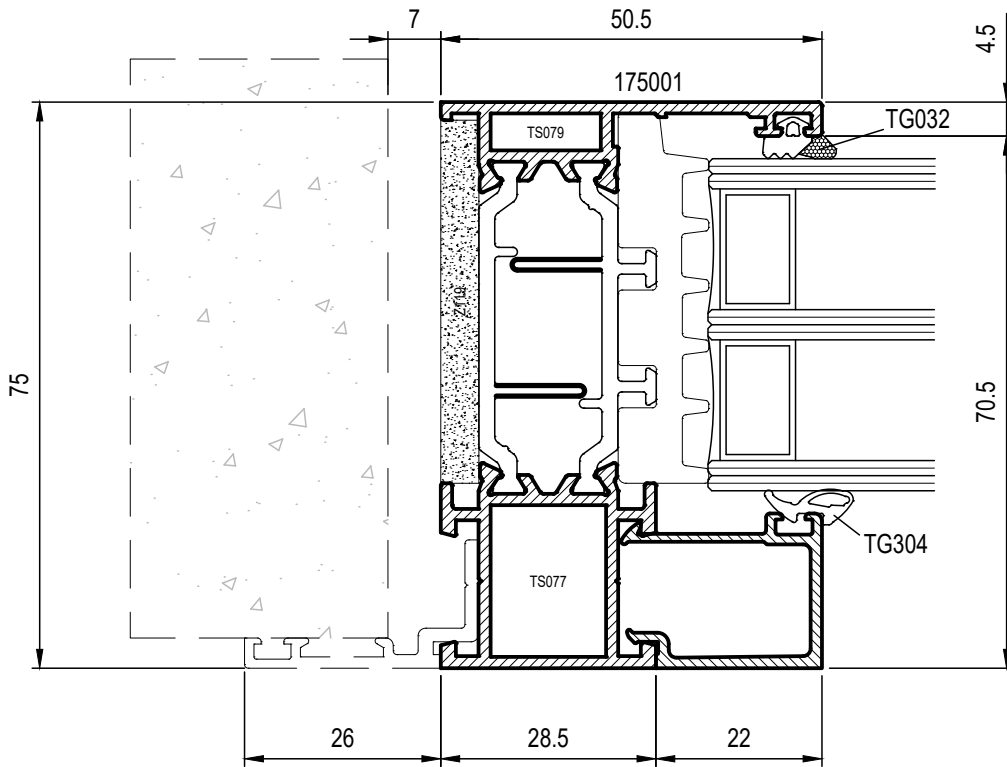

APERTURA INTERNA

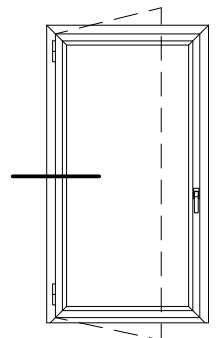
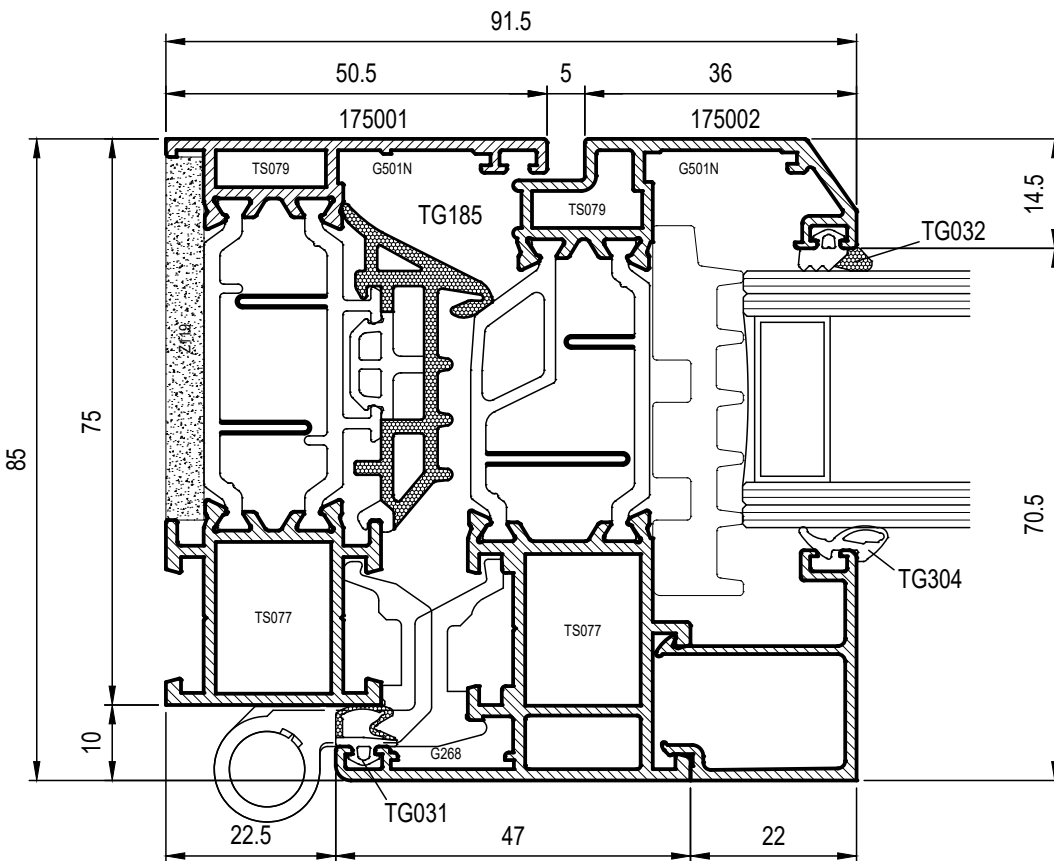

DUE ANTE SOLUZIONE Z - RIPORTO - Z

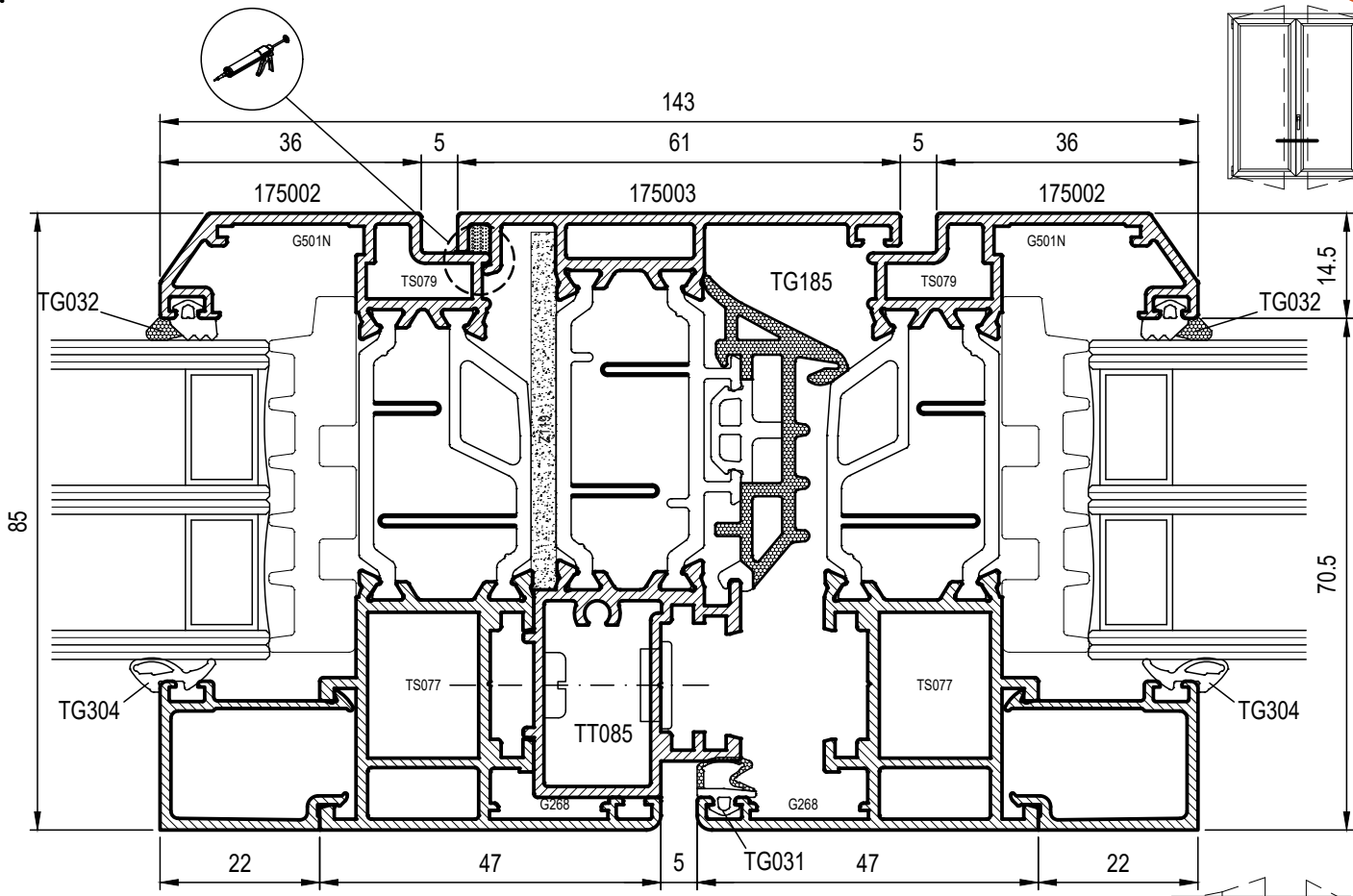

TERZA ANTA
SOLUZIONE Z - RIPORTO - Z

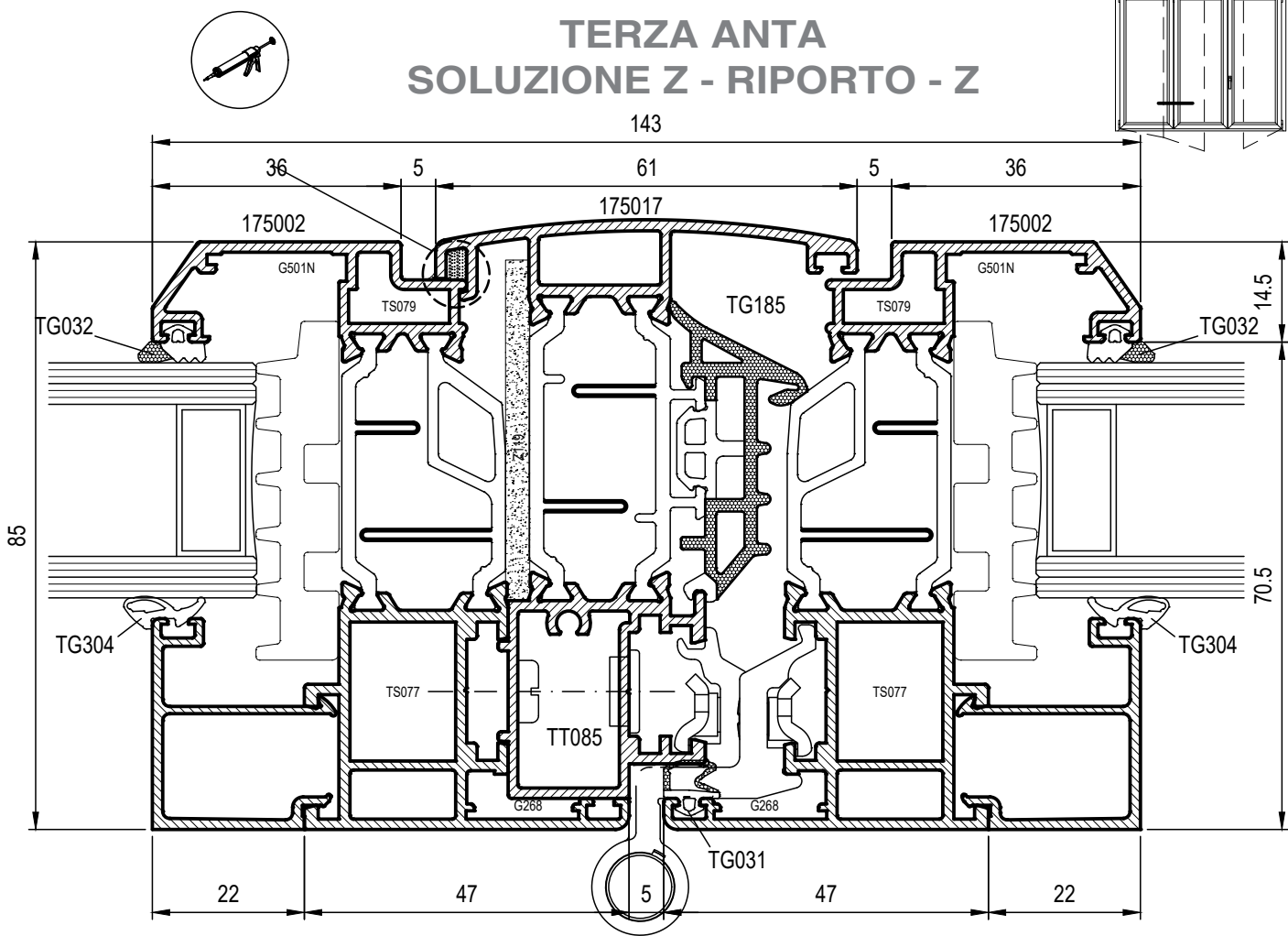

TRAVERSO INTERMEDIO

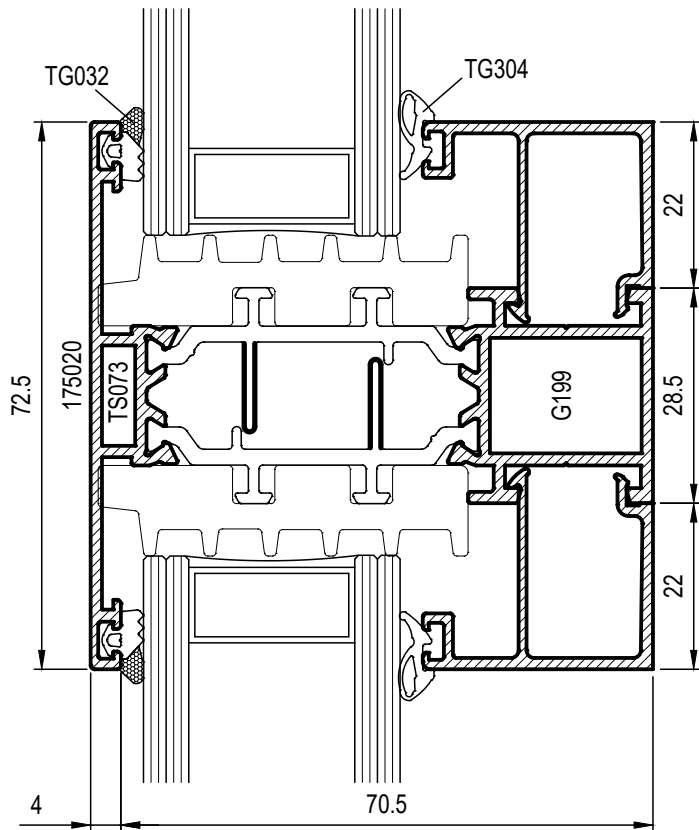
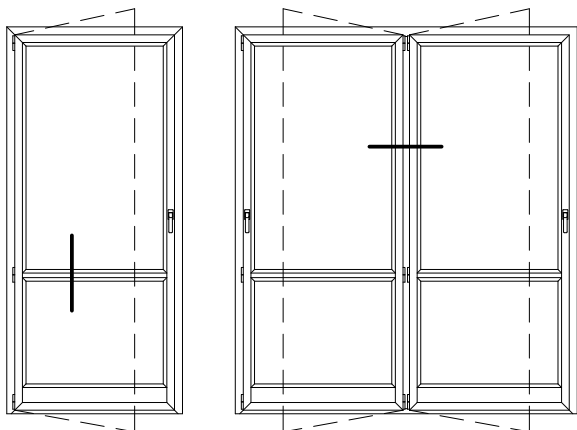

APRIBILI AFFIANCATI

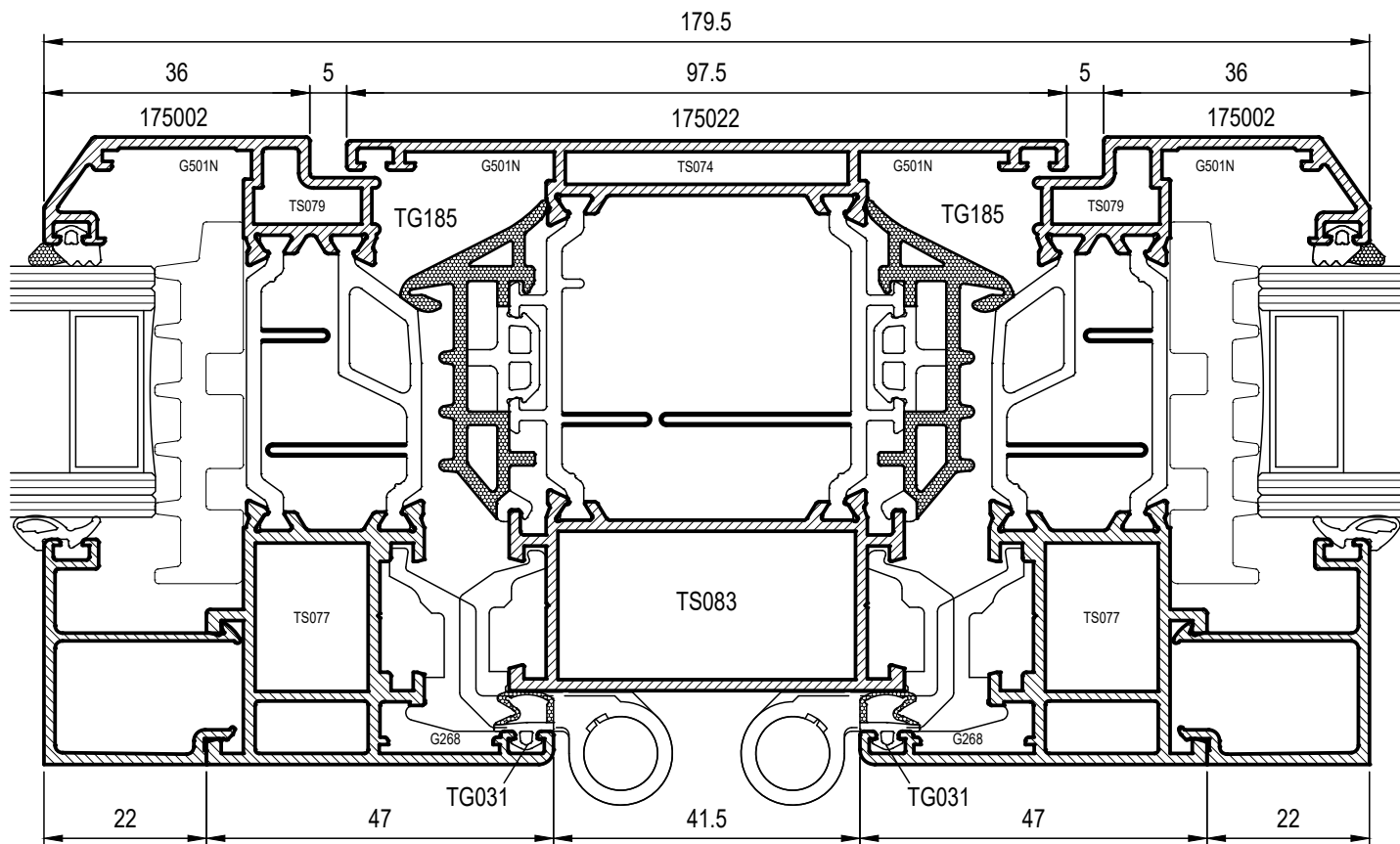

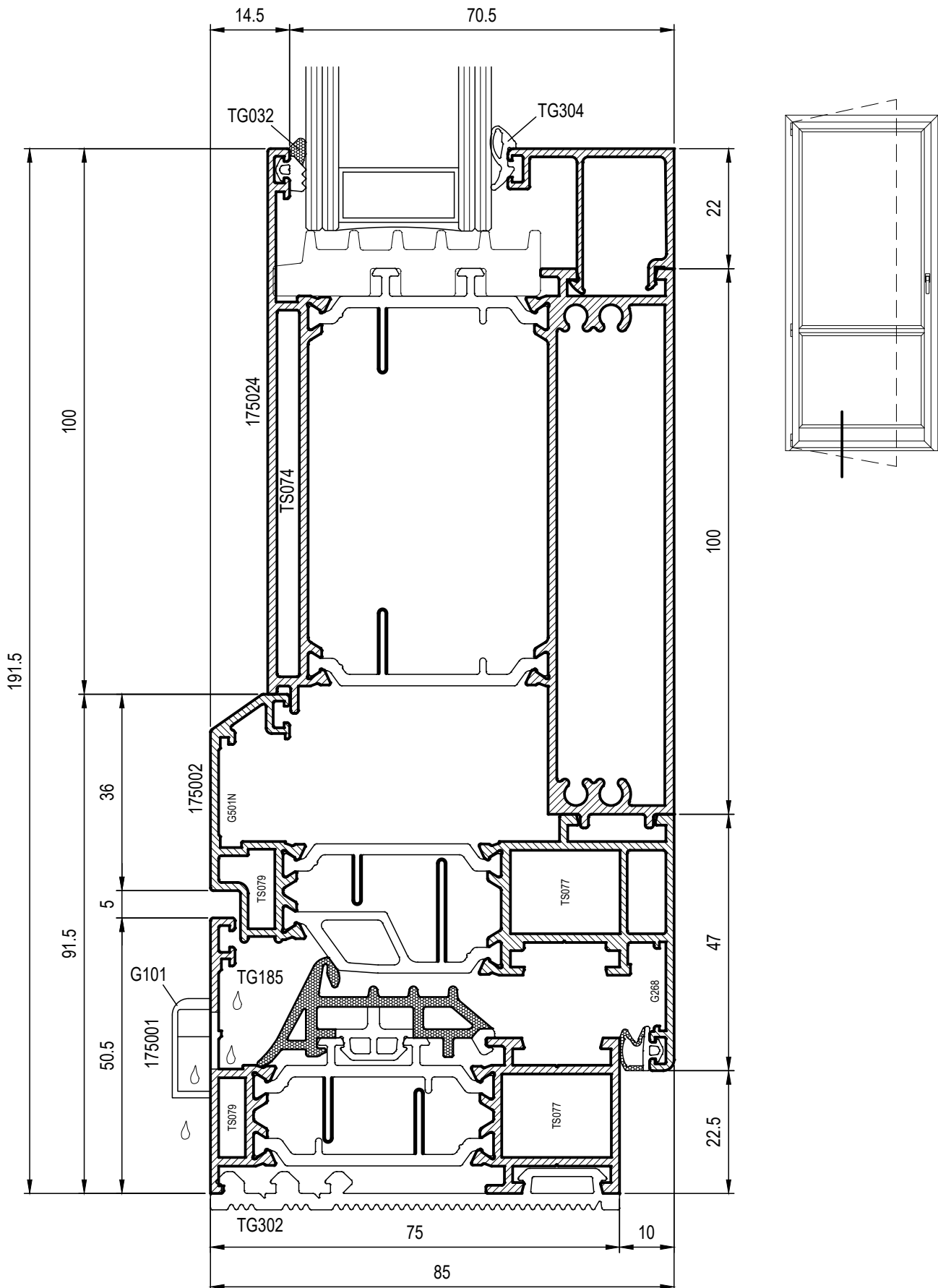

SOGLIA RIBASSATA PORTA BALCONE

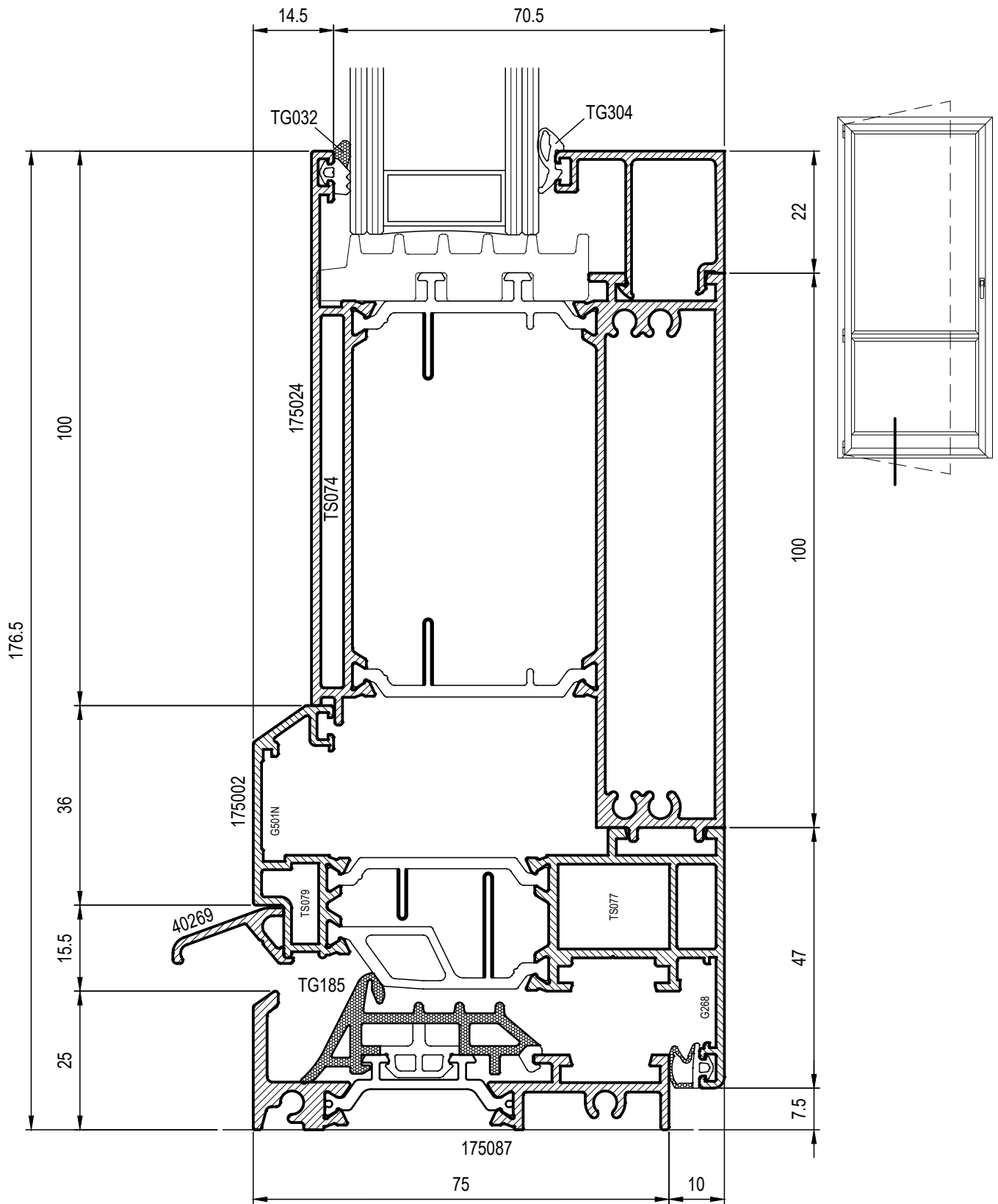

N.B. SOLUZIONE SCONSIGLIATA IN CASO DI SERRAMENTI PARTICOLARMENTE ESPOSTI

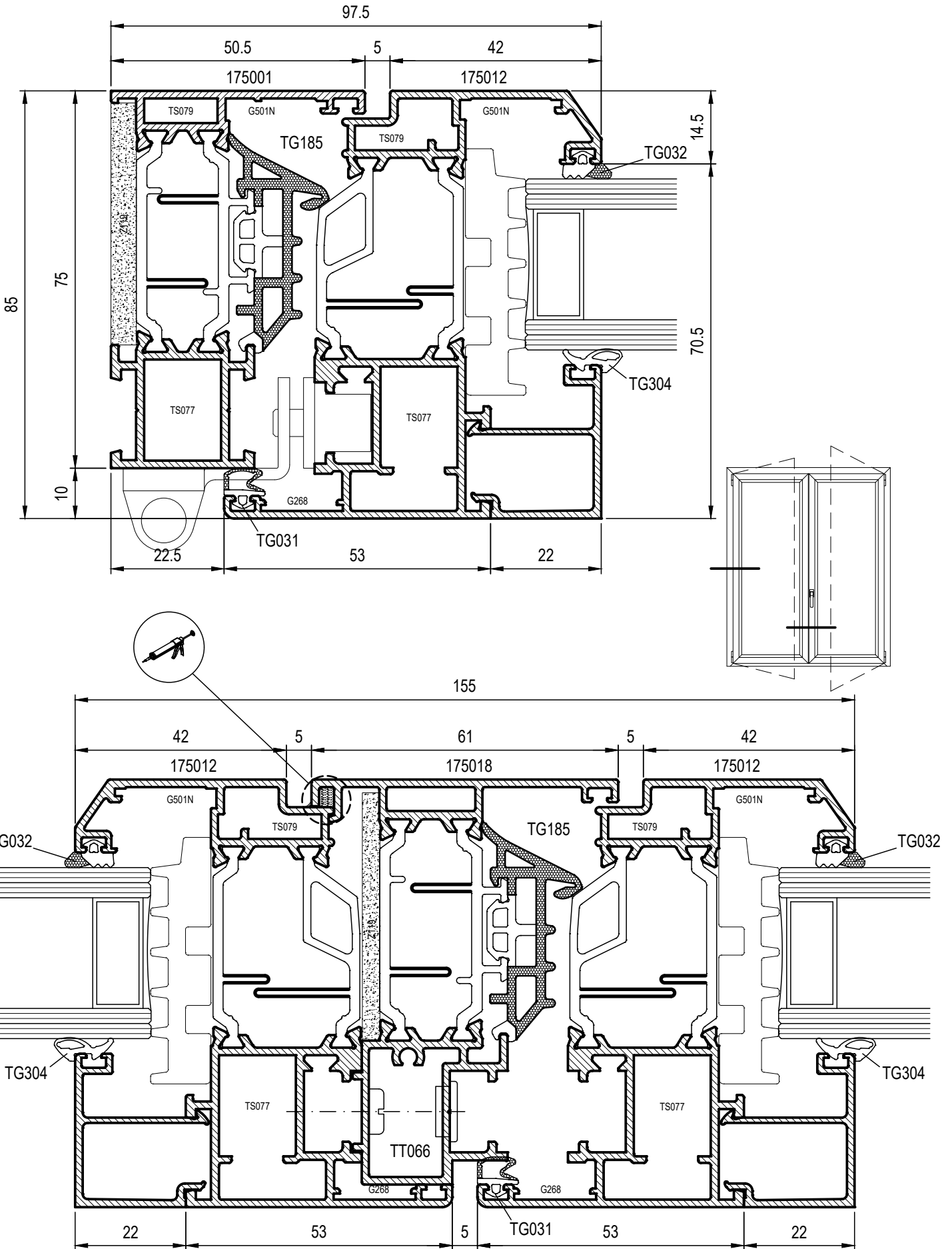

APERTURA INTERNA CON ANTA PIANA

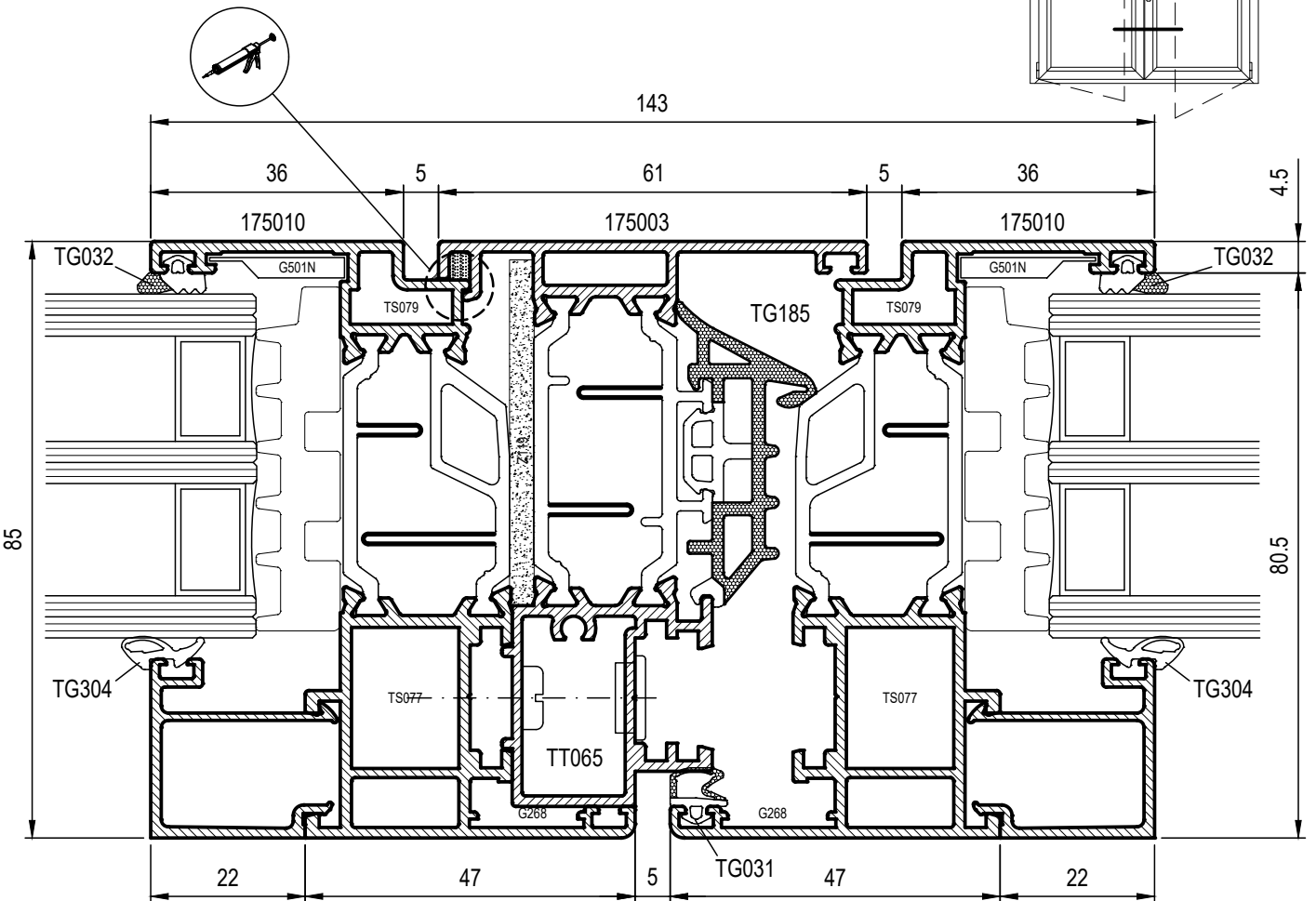
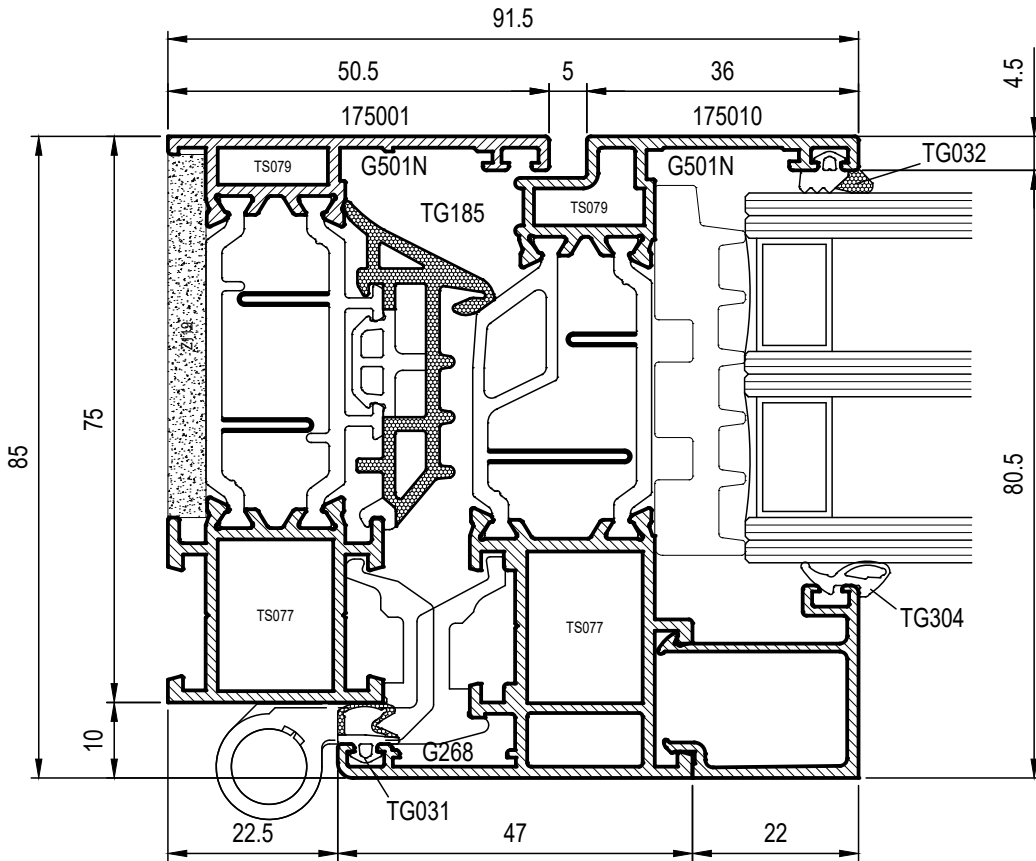

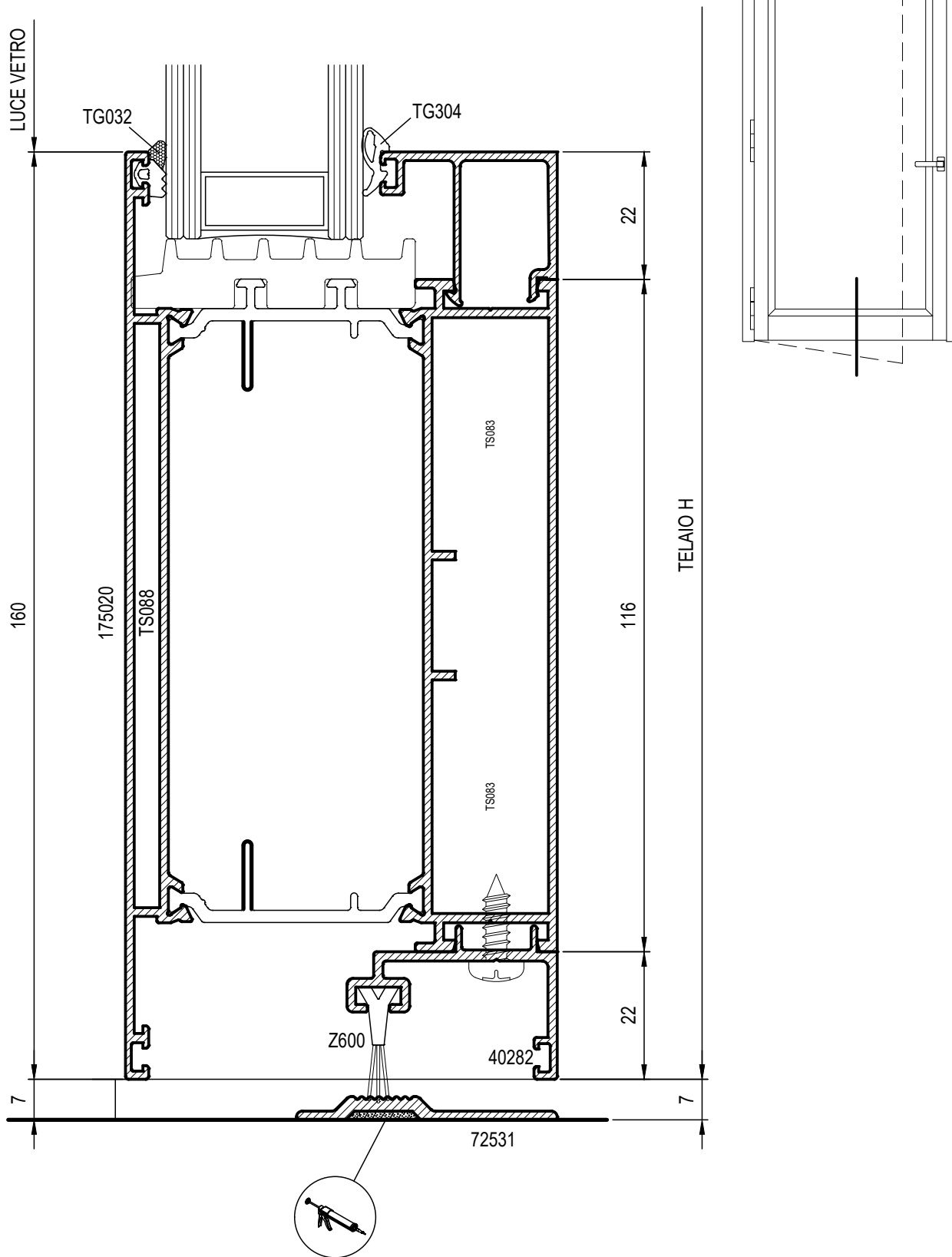

ZOCOLO

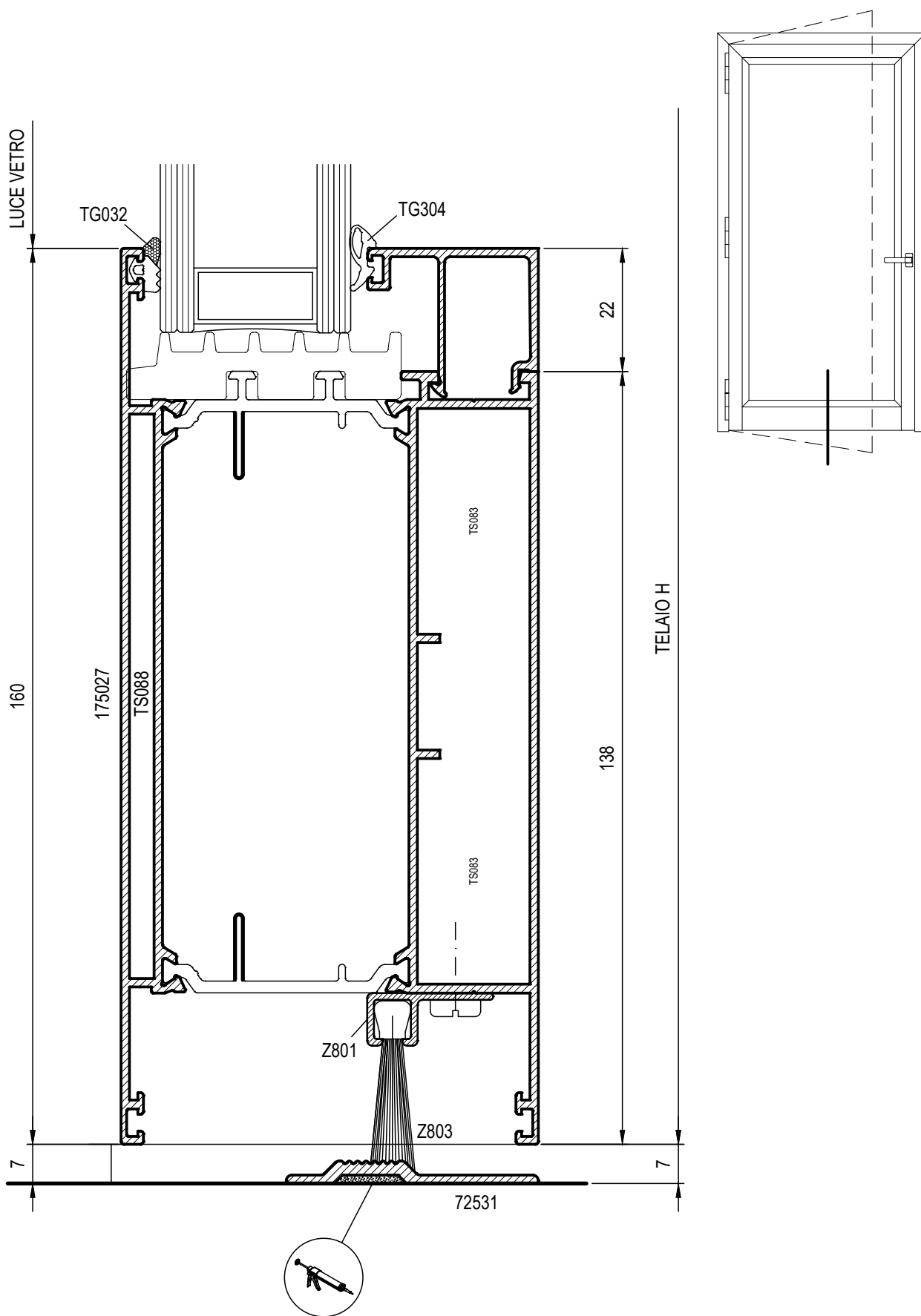

MONOBLOCCO CON SPALLA
A PROFILATO UNICO

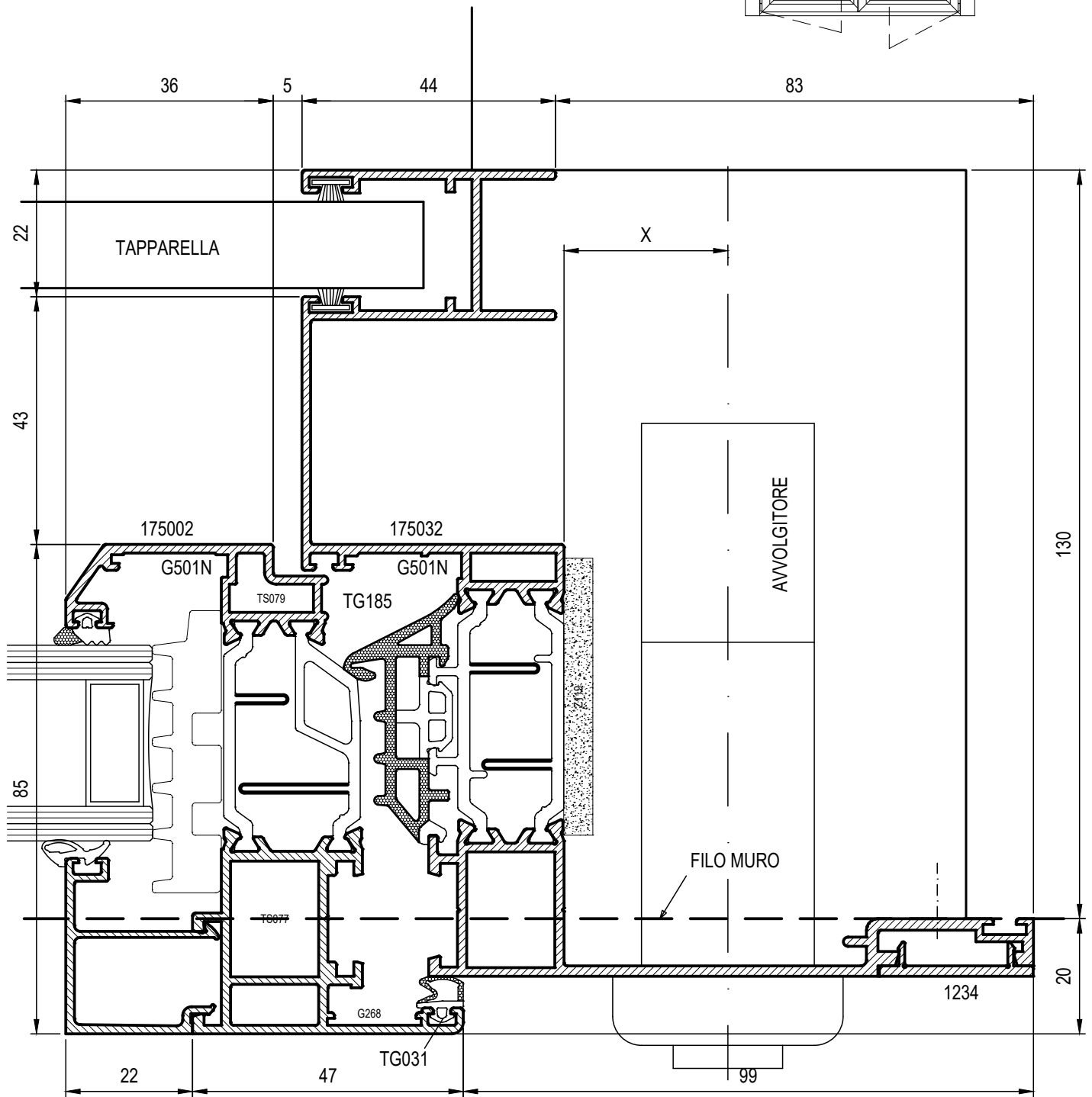
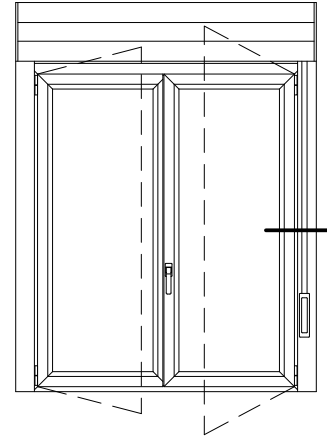

Nodi Scala 1:1



CIELINO MONOBLOCCO

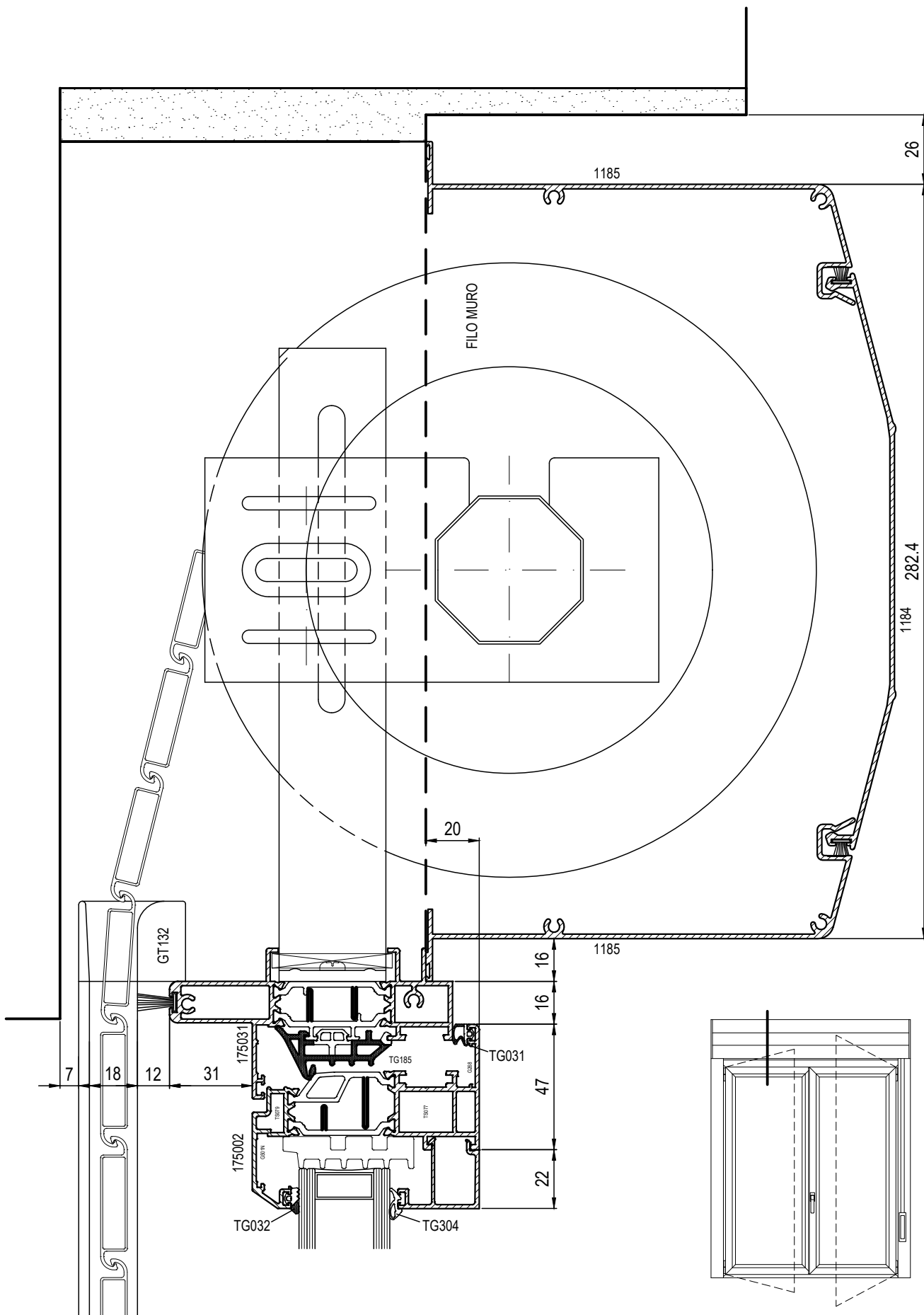

SCORREVOLE PARALLELO
BINARIO INFERIORE

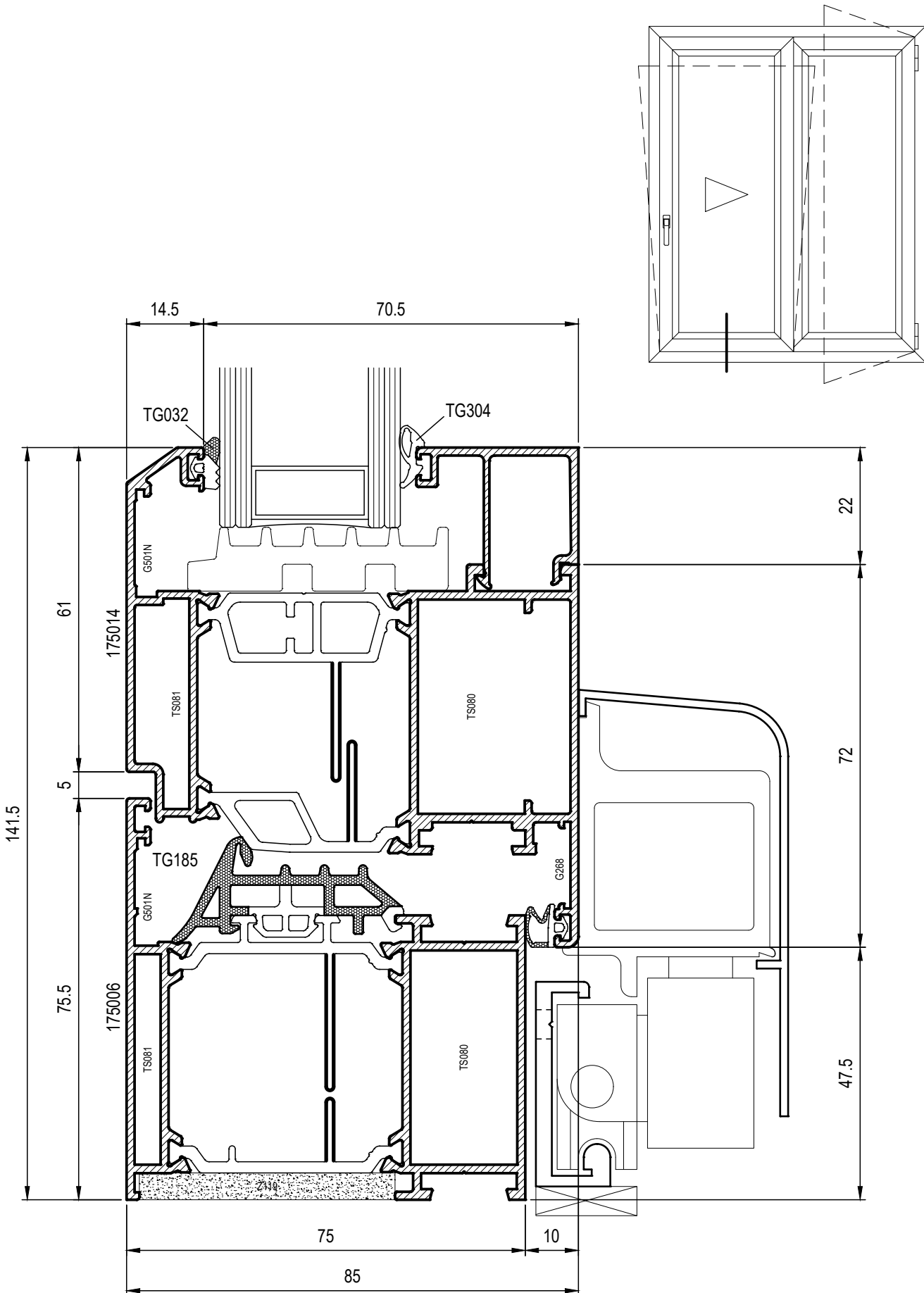

SCORREVOLE PARALLELO
BINARIO SUPERIORE

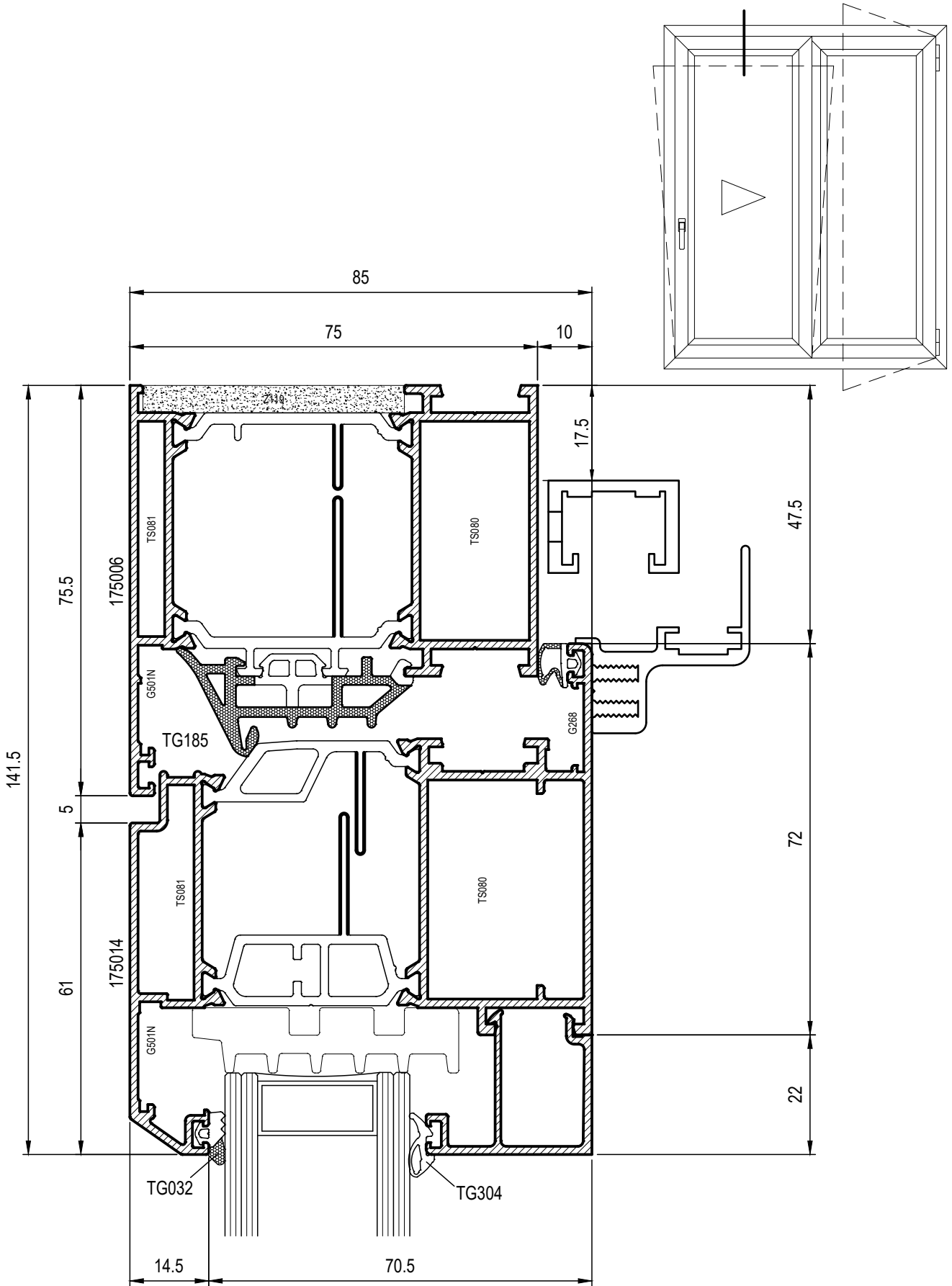

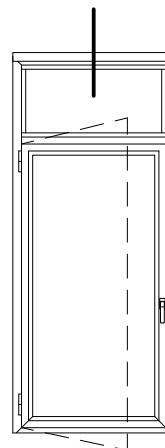
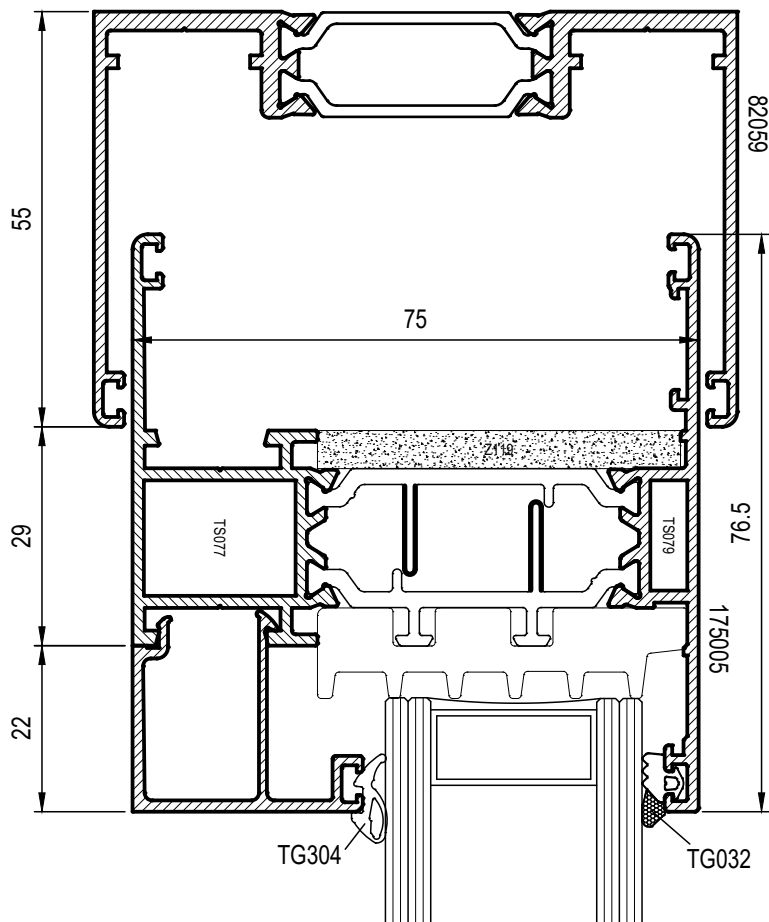

APERTURA INTERNA PROFILATI MAGGIORATI

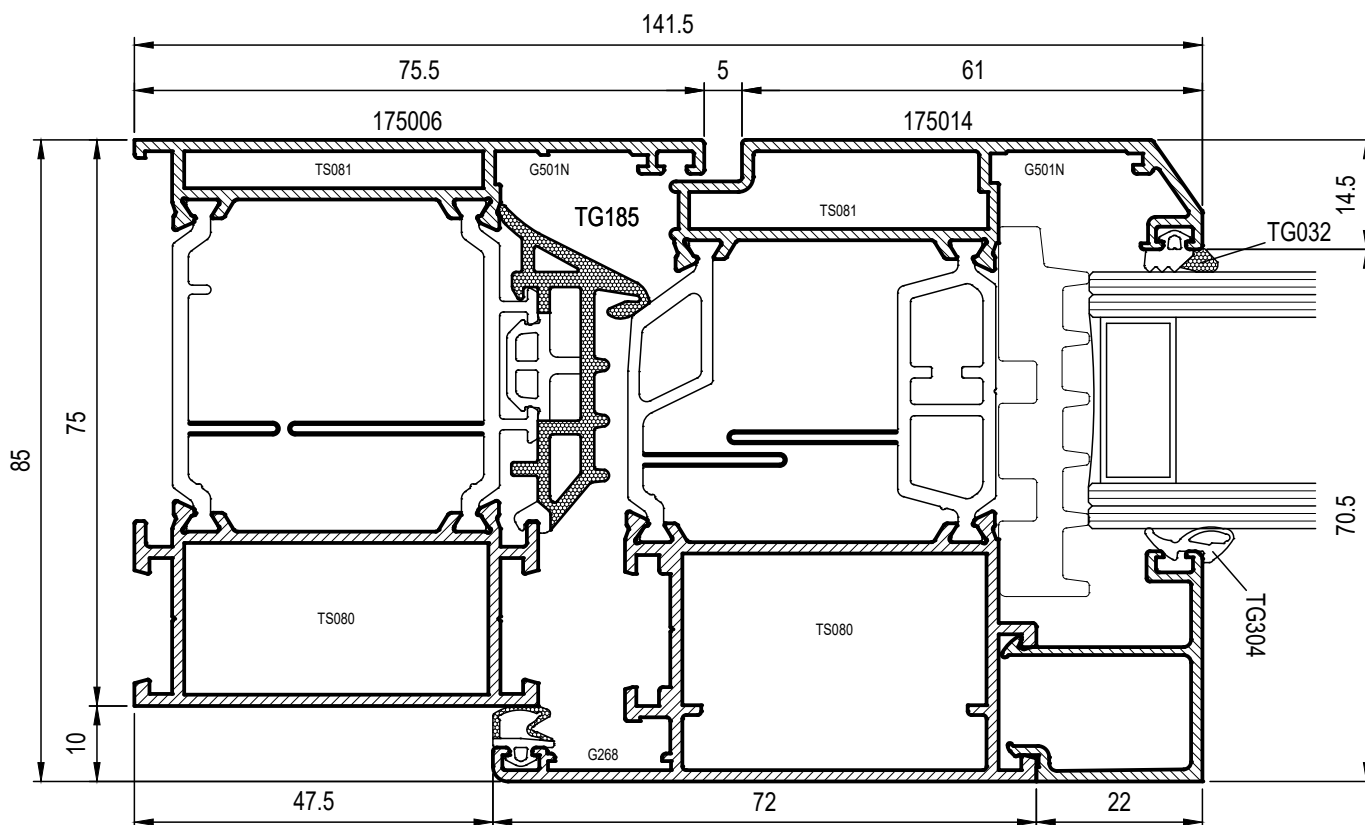
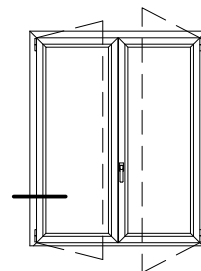

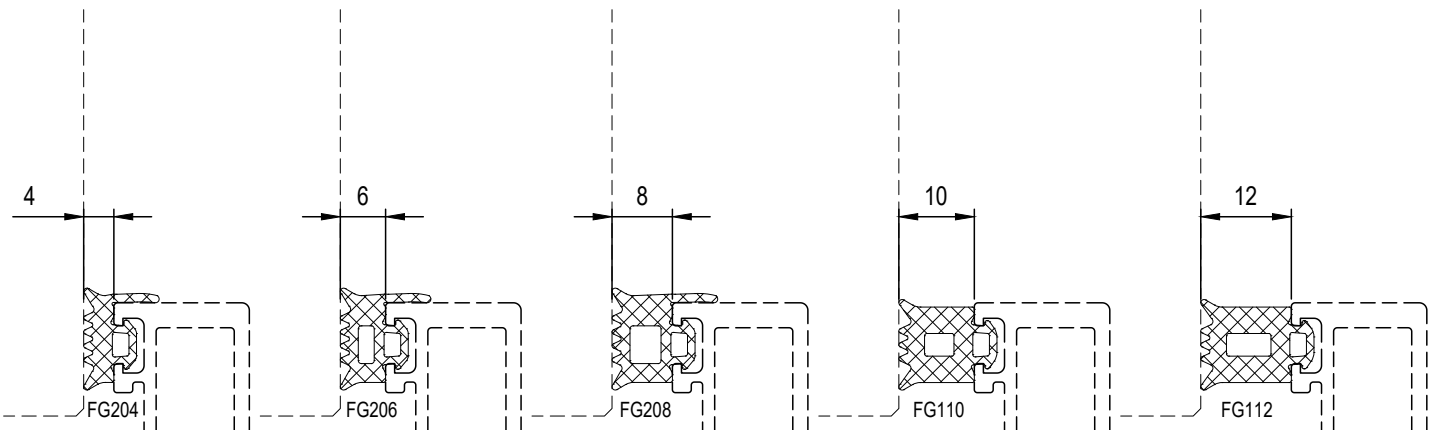
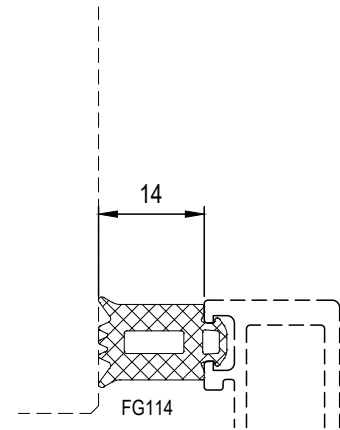
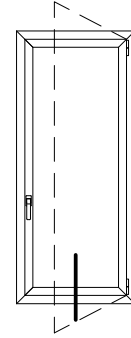
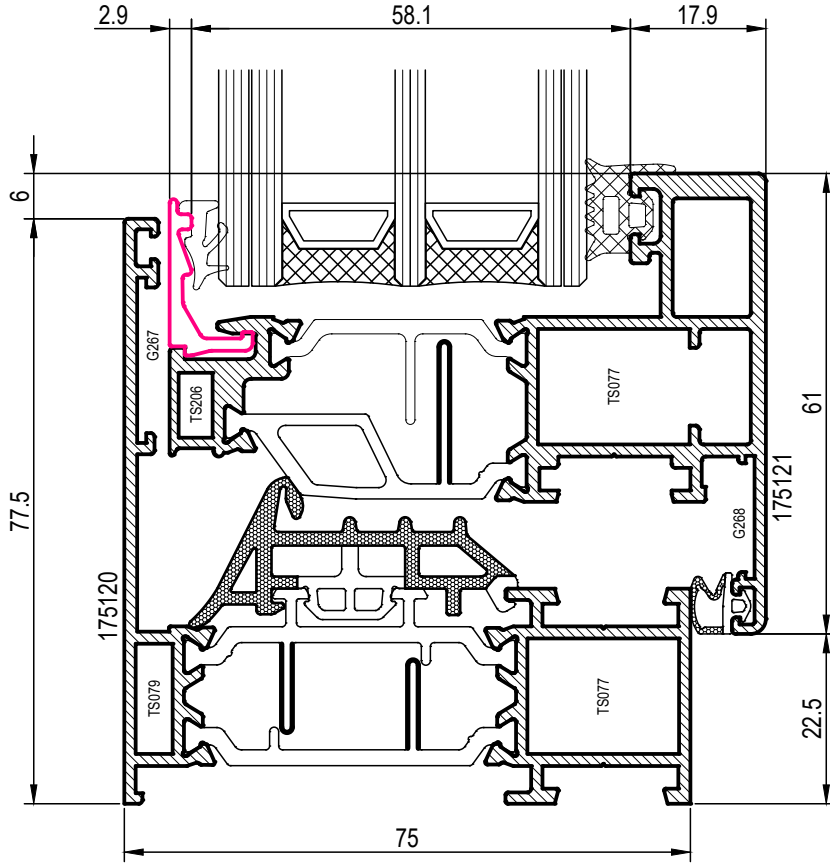

LATERALE E CENTRALE ANTA A SCOMPARSA

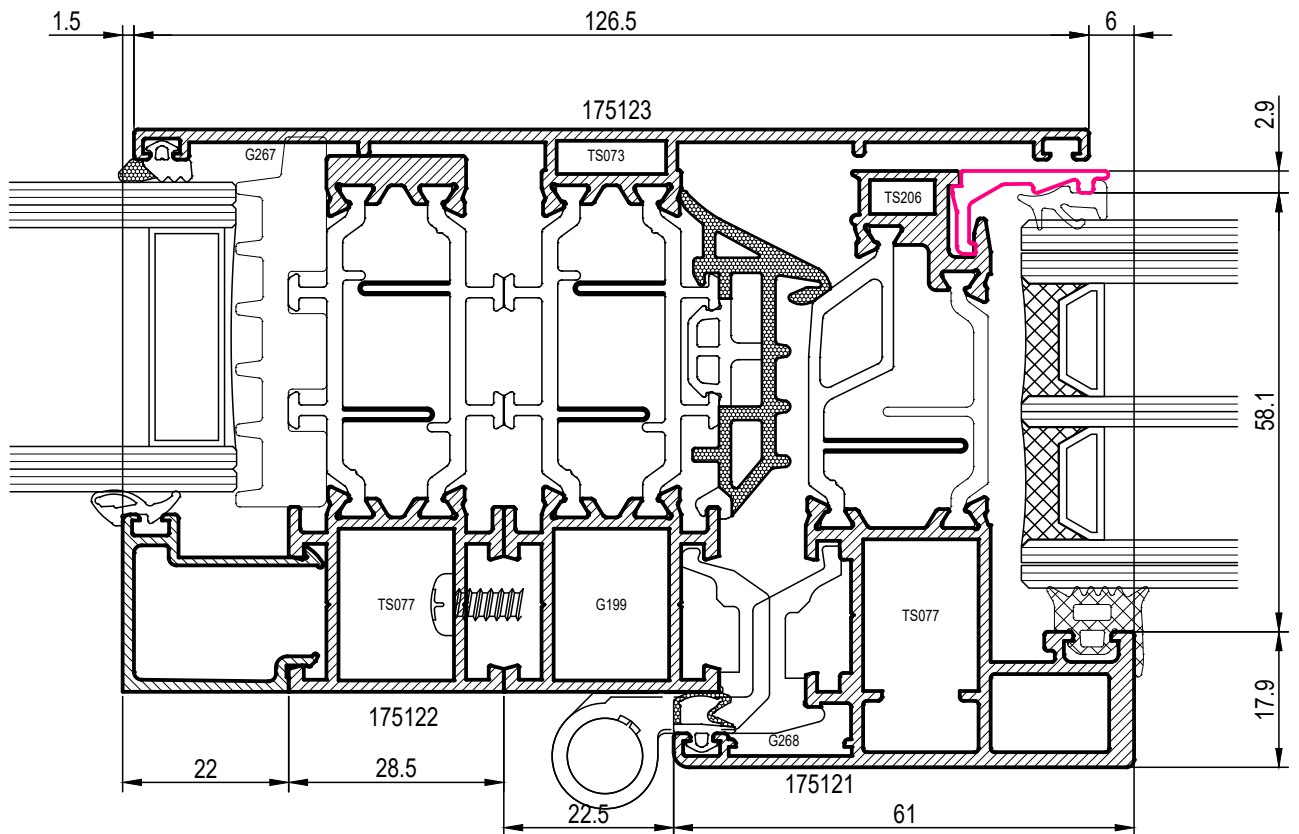
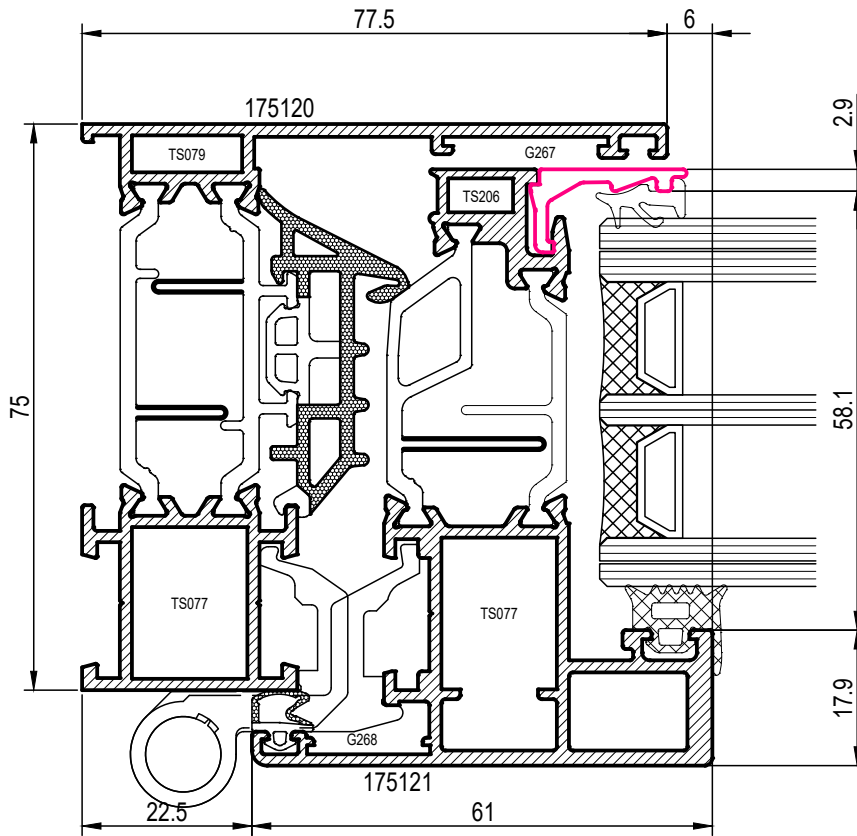

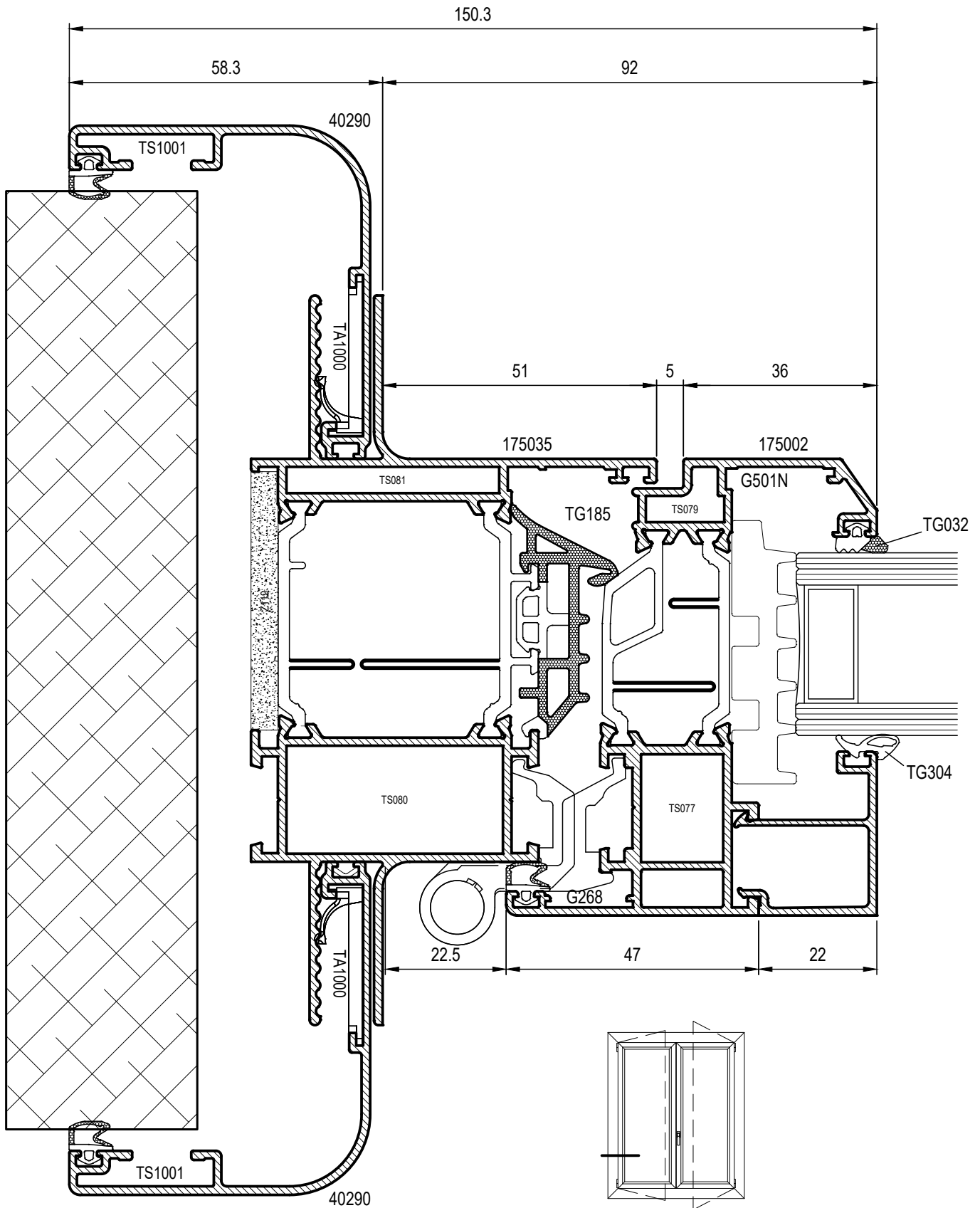



INDINVEST LT S.r.l. a socio unico
S.P. Ninfina II Km 1,200
04012 - Cisterna di Latina (LT)
Tel. +39.06.960.27.1

Per informazioni:
www.indinvest.it
ufficio.tecnico@indinvest.it